

Operating Instructions

Pedestrian Turnstile

Type MPT 33

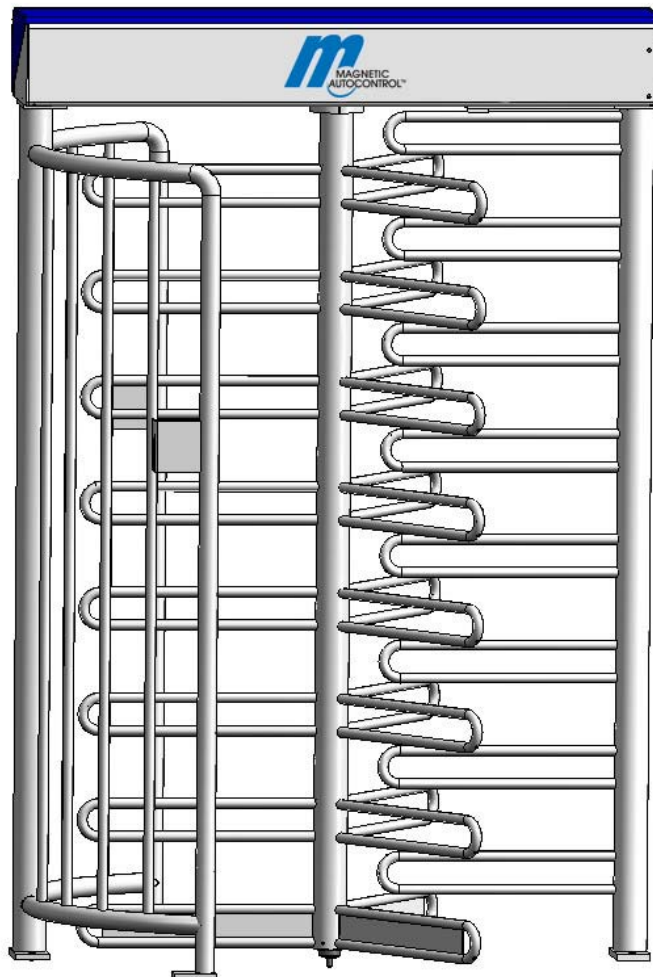

Contents

1. Delivery	3
2. Safety	3
3. Description and operation	6
4. Foundation	8-10
5. Assembly and installation.....	11-17
6. Electrical connection	18-19
7. Access control devices.....	20
8. Commissioning.....	21
9. Controller MSC 10.....	22
10. Adjustable parameters.	24
11. Operation modes.....	26
12. Technical support.....	28
13. Spare parts and accessories.....	28-30
14. Instructions for exchange and adjustment of micro switch.	31
15. Warranty.....	31
16. Decommissioning and disposal.....	32

1. Delivery

The Security Turnstile consists of:

- 1 x Semi cage made of stainless steel or mild steel
- 1 x Center column 3 x 120°, stainless steel or mild steel
- 1 x Top housing with locking unit
- 1 x U-bar locking unit
- 1 x Electronic controller MSC10
- 1 x Set of documents inside the lockable top cover
- 1 x Fixing anchors (in Europe only)
- 2 x Keys for the top cover

Technical Data:	Type	MPT 33
Protection	IP	43
Voltage VAC		230
Frequency	Hz	50
Current	A	2,5
Duty Cycle	%	100
Weight	Kg	320
Height	mm	2230
Diameter	mm	1300

2. Safety

2.1 General safety notes

The Magnetic pedestrian turnstile has been designed, built and tested according to the latest technology. Although it has left the factory in a fully operational and safe condition, it is important that the installation is carried out correctly therefore the operating instructions must be read carefully and the safety notes must be observed.

Any liability and warranty is declined by the manufacturer in the case of incorrect use and use for purposes other than intended.

2.2 Use for the intended purpose

The Magnetic pedestrian turnstile may be used only to control pedestrians entering or exiting restricted areas, usually under surveillance.

The Magnetic Universal Controller may be used only for controlling the Magnetic pedestrian turnstile. Any other use is not permitted.

Conversions and modifications to the turnstile or to the control modules are not permitted.

Only original spare parts and accessories from Magnetic may be used.



NOTE!

MAGNETIC does not assume responsibility for any damages or injuries to persons that result from non-observance of the operating instructions or inappropriate use!

2.3 Warnings and symbols used in this manual

The following symbols and references are used in this manual to give instructions and warnings (cautions) of particular importance. These must always be strictly observed!

Purchased components may have additional specific warnings that also need to be strictly observed.



WARNING!

This Symbol indicates an imminently hazardous situation which, if not avoided, will result in death or serious injury.

The description of the situation is followed by measures of avoidance.

Please read and observe the given instructions very carefully.



CAUTION!

This Symbol indicates a potentially hazardous situation which, if not avoided, could result in property damages and material destruction.

The description of the situation is followed by measures of avoidance.

Please read and observe the given instructions very carefully.



NOTE!

The symbol “note” is used in case of an operating procedure or condition which is essential and, therefore, noted to gain special attention.

In addition the symbol indicates a potentially situation which, if not avoided, may result in an undesirable result or state.



RECYCLING!

When disposing of the unit at the end of utilisation ensure those noxious and dangerous residues are disposed of in accordance with the regulations. Based on the different material, disposal must occur in a separate manner.

The used lubrication and auxiliary material such as oils and fats will be disposed of in accordance with the statutory provisions.

2.4 Safety notes

- Disconnect all external opening or closing devices (remote control, control desk, etc.) during maintenance work.
 - Do not operate the equipment without effective anchoring to the foundation.
 - A main supply power circuit breaker must be installed.
 - This operating manual and any other additional information must be kept in a, for all authorized person, accessible location.
 - Before commissioning make sure all electrical and functional features are tested.
 - The electrical wiring must comply with these instructions.
 - Only certified and trained electrical technicians shall perform any electrical work.
 - Before any maintenance or troubleshooting work the main power supply must be disconnected.
 - Electrical voltage components like transformers, solenoids, resistors, and stator housings of motors, lamps etc. may be hot during and after operation. Do not touch such components; it can cause skin burns.
-
- Disconnect all external opening or closing devices (remote control, control desk, etc.) during maintenance work
 - It is prohibited to install the barrier without proper mounting to the foundation
 - A main power switch or residual current operated device is compulsory
 - Risk of bodily harm while cover is open
 - Pedestrian barriers are maintenance free
 - Documentation should be easily accessible.
 - Before commissioning make sure all electrical and functional features are tested.
 - Permissible environmental conditions

- The electrical wiring of the barrier must comply with the included drawings.
- Only certified and trained electrical technicians may perform the electrical connections
- Only certified and trained electrical technicians may remove covers for mains plug, mains receivers or wirings
- Before repairing electrical failures disconnect fuse
- Risk of bodily harms while closing the cover
- As part of the maintenance work, the fixing bolts must be checked and tightened, if necessary.
- Current carrying components like transformers, solenoids, resistors, stator housings of motors, lamps etc. shall not be touched while in operating-temperature condition; this can cause skin burns

3. Product description

The MPT series of turnstiles are designed to control pedestrians entering or exiting restricted areas outside in high security situations. The turnstile consists of four different component parts (see fig. 1) It can be used for bi-directional access control by means of keys or card readers (access control devices in general). Entry and exit of the barrier can either be operated in open, controlled or closed modus. The rotating centre column consists of 3 x 120 degree U bars. The controller, the drive units and the locking device are mounted on top of the centre unit in a powder coated sheet metal enclosure, where there is also space for additional access control equipment .Locking and release of the centre is realized by an electro-mechanical locking device with solenoids.

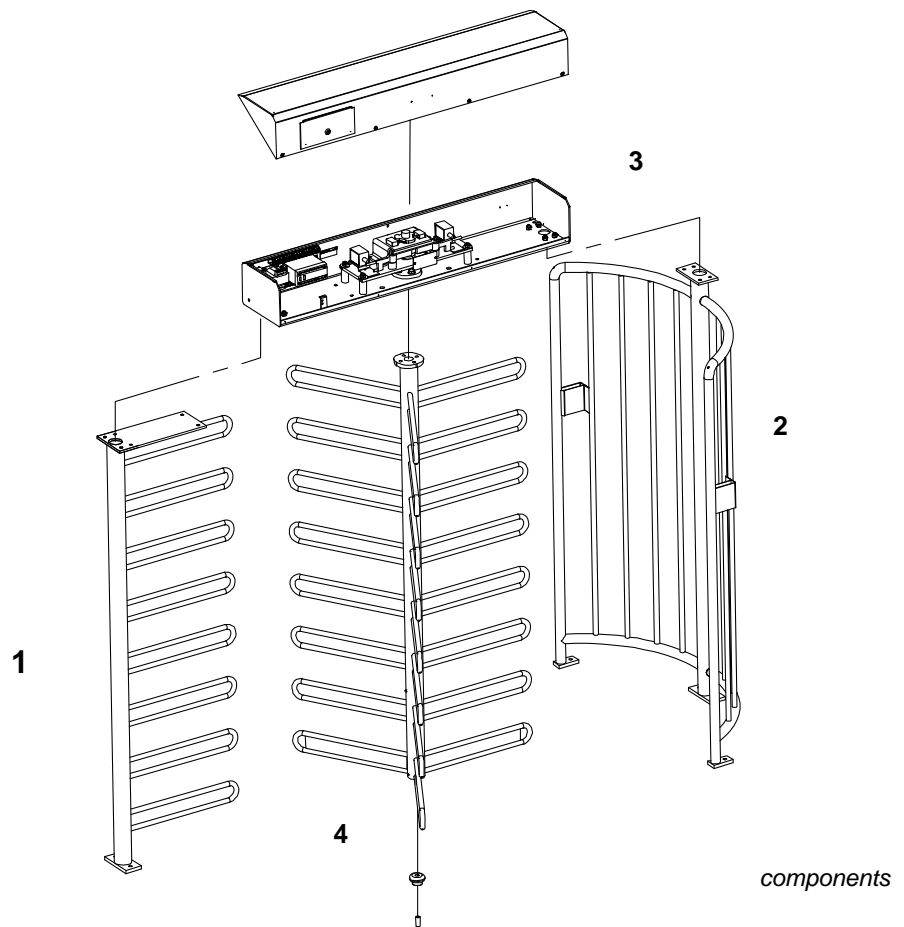

Fig. 1 Design of components

- 1 Lock comb
- 2 Cage half(s)
- 3 Upper housing with locking unit
- 4 Center column

Operating Instructions

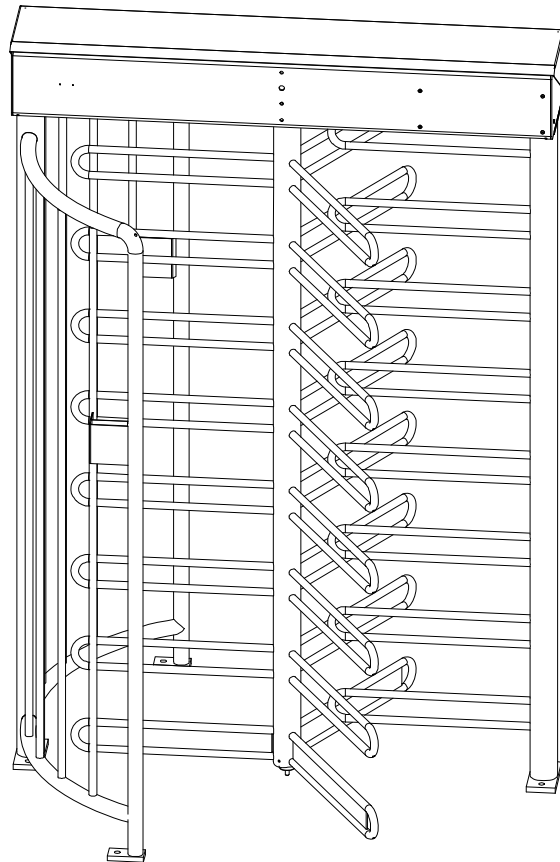

Fig.2
Entry "left version"

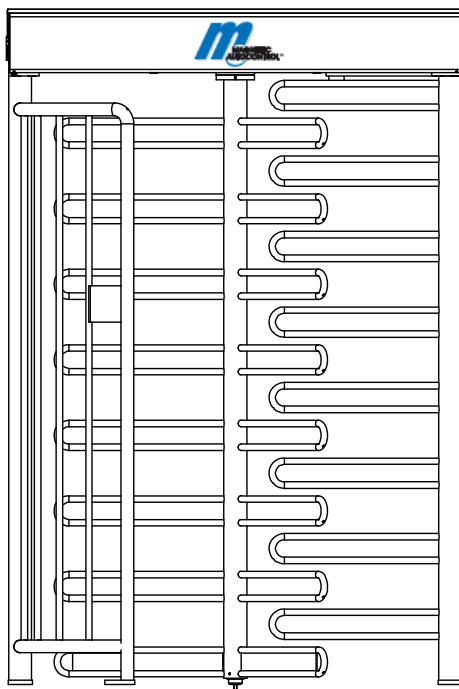

Fig. 2.1 Entry "left version"

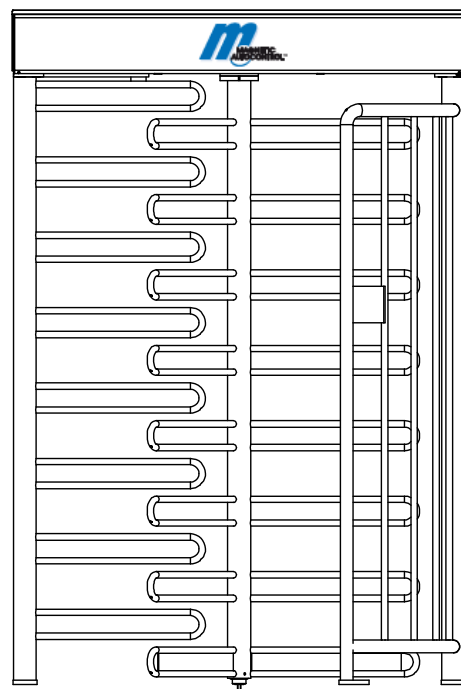

Fig. 2.2 Entry "right version"

4. Foundation

A level concrete mounting surface is required to secure the turnstile housing. For the dimensions please refer to figure 2. The cables should finish a minimum of 5 meters above the finished concrete surface.

NOTE: This foundation is also required in connection with a foundation frame.

Conduits for mains supply and data lines should finish 50 mm approx. above foundation

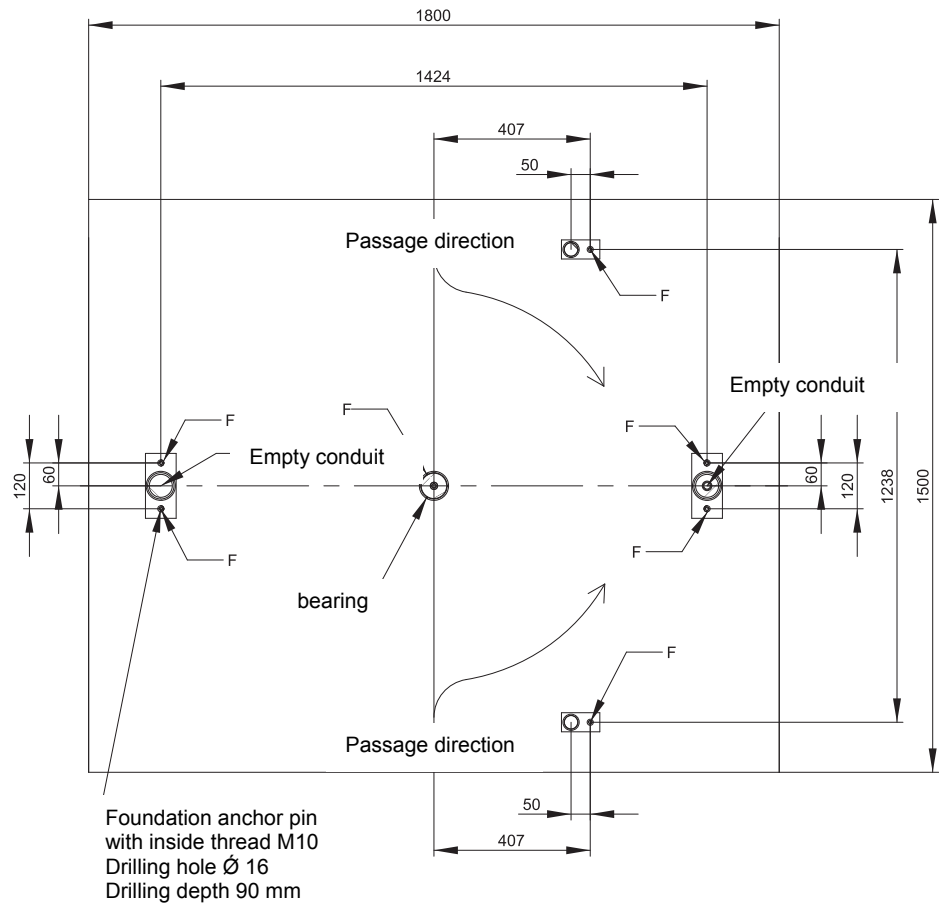

Fig.3

Operating Instructions

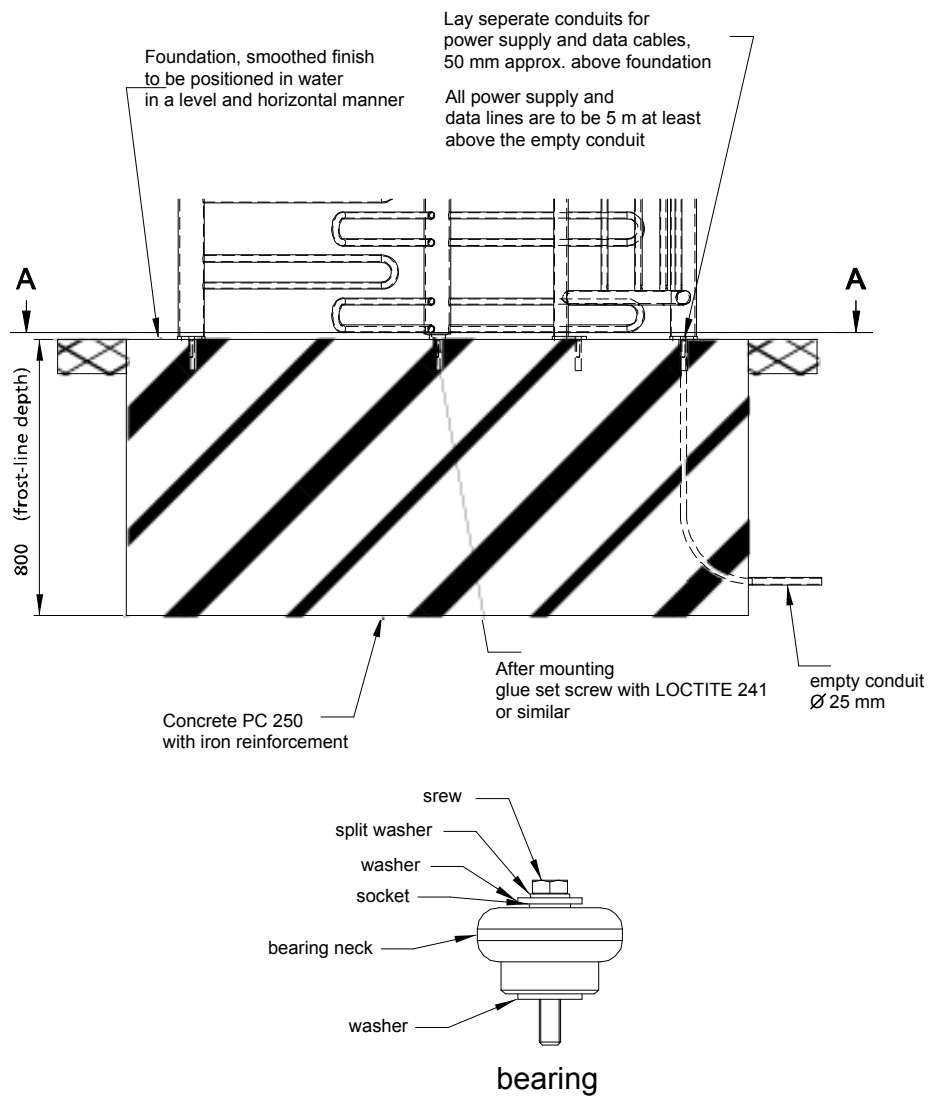

Fig.4

4.1 Foundation frame

The foundation frame is required for turnstiles to be mounted on an uneven surface, for example in case of pavers. A level concrete mounting surface is required for correct mounting of the foundation frame. It should be approx. 150 mm below the finished surface.

The foundation frame must be positioned in its desired location taking care on which side (right or left), you want to place part 2. This is important in case you want to mount access control units at part 2.
(See Fig 2.1 / 2.2, Fig. 5.1 / 5.2, Fig. 6)

Installation of the foundation frame:

- First of all put the frame in place
- Drill the fixing holes
- Insert the fixing screws
- Install the foundation frame by means of jackscrews in water (if needed, even out with suitable underlayment)
- Then fix the foundation frame
- Pay attention to correct cable guiding to the turnstile
- Empty conduits must not be squeezed
- Please consider the cure time of the chemical anchor studs

With the installed foundation frame, the mounting of the turnstile can be carried out in the same way as on a concrete foundation. (See chap. 5)

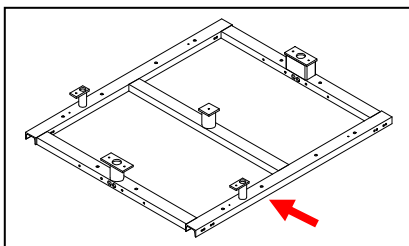

Fig. 5.1 Entry Left version

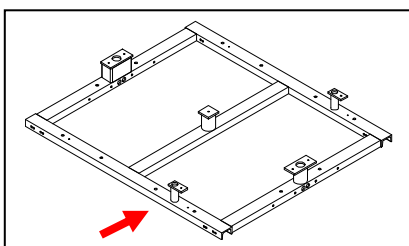

Fig. 5.2 Entry Right version

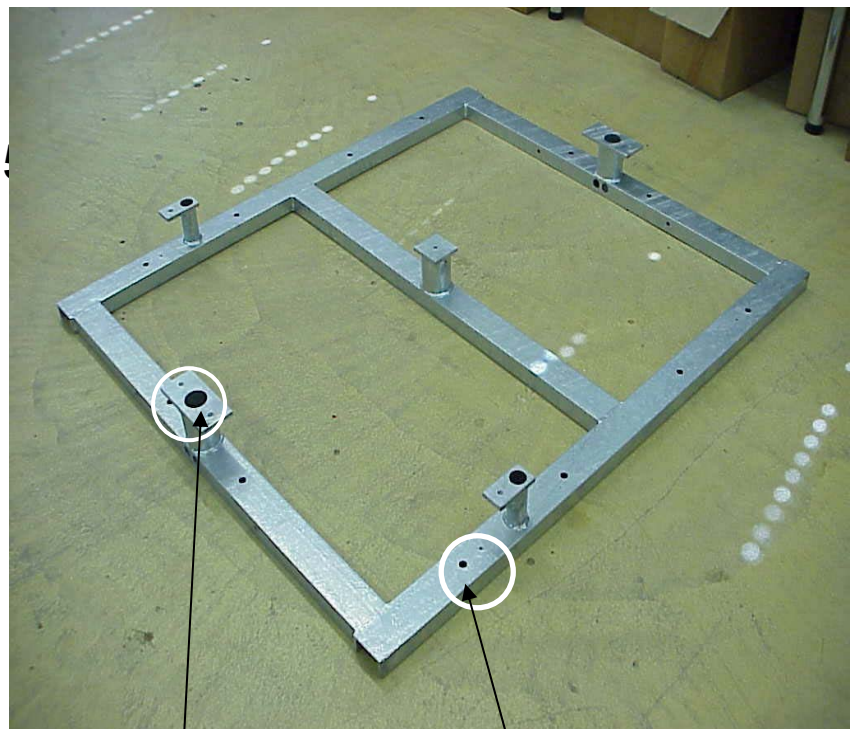

Fig.5

Cable routing from foundation into turnstile

Jackscrews
For positioning the foundation frame on the concrete, if necessary.

5. Assembly and installation

5.1 To fit the turnstile (above ground foundation)



- The turnstile should be positioned in its desired location taking care on which side (right or left) you want to place part 2. (See Fig. 2.1/ 2.2, Fig. 6) This is important in case you want to mount access control units at part 2.
- Set Foundation drillings 7 x M16 as per drilling plan figure 3!
- Use the provided drilling template
- Mount threaded rod (see enclosed separate description)
- Wait till bolts are cured (see separate description)
- Mount the components in correct order (part 1, 2..) onto the foundation, however, do not tighten entirely the bolts in order to compensate any drilling offset which may occur afterwards. Use screws 6 x M 10 x35. Grease the screws before.

Note:
Part 3 should be mounted, that the cover is to open from the secure side (inside).

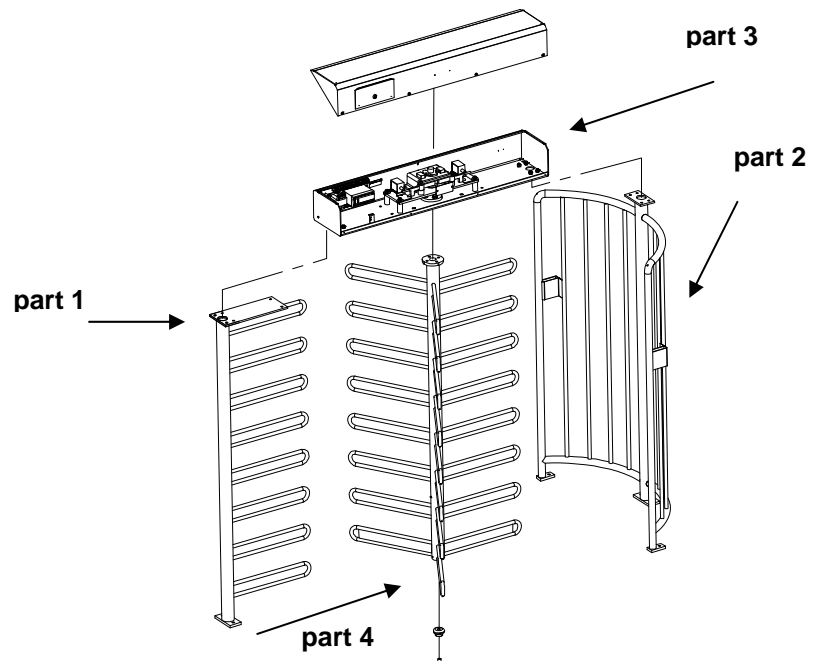

Fig.6



- Place part 3 upon part 1 and 2. Use screws 8 x M12 x 35 and counter nut. **This part of installation is dangerous. Make sure, that nobody stays under Part 3, until this part is securely fixed.**
- Mount lower bearing (see fig. 8). Using screws M10 x 70. Grease them before.
- Put part 4 on the lower bearing, **see fig. 10 and 11** and screw it up by means of 4 x M16 x 40 with U-discs and flange. Be sure that the turnstile is in locked position. (Please consider the marking of the flanges!) see fig. 12
- Now tighten all fixing bolts.

5.2 Fixing on foundation frame

See section 5.1 fixing the foundation.

However in this case the turnstile is mounted on the flanges of the foundation frame.

Fixing of foundation frame, see section 4.1



5.3 Opening of the top cover



The hood is fixed with 4 hexagon socket screws. Unscrew them with an allen key. (fig. 7).

Lift-off the hood (towards yourself) (fig. 7.1)

Fig.7

1

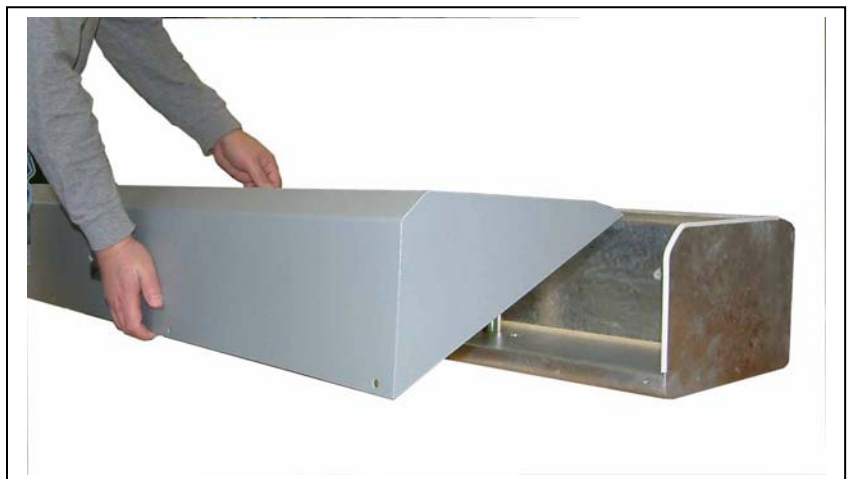

Fig.7.1

To fit the turnstile (above ground foundation)

Fixing of the turnstile is done by means of the 8 fixing bolts M8 and plain washer.

After final positioning tighten all bolts firmly.



Note:

1. Mark the dimensions onto foundation acc. to fig.4
2. Drill
3. Install turnstile
4. screw together (see fig. 5.1)

Fig. 8

Please consider the home position of the locking unit when mounting the center column.

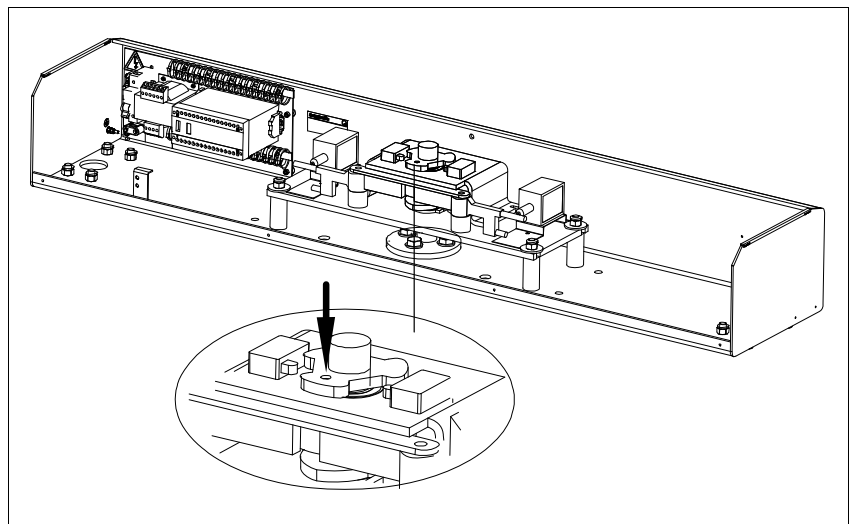

Fig. 9 Upper housing with locking unit

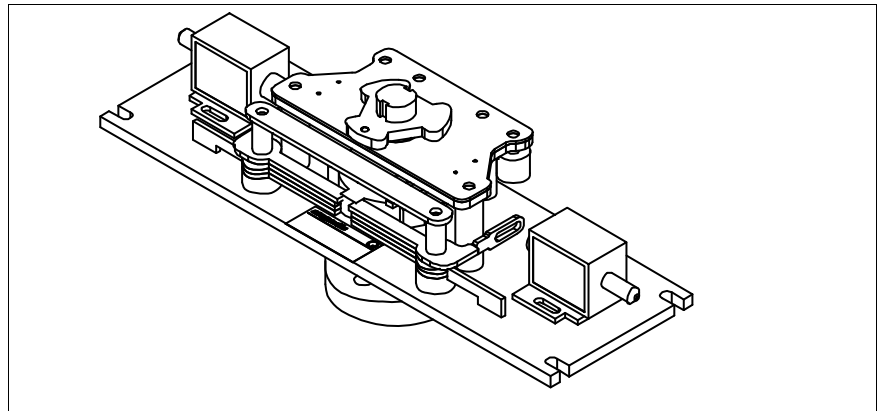

Fig. 9.1 Locking unit

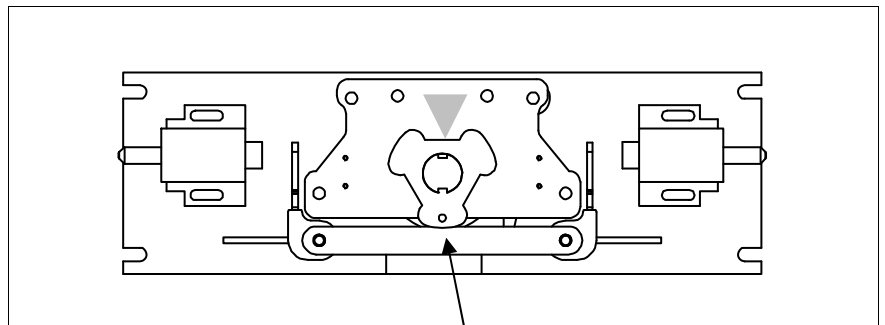

Fig. 9.2 ▼ The home position is reached, when the Countersink is in the position as shown (fit-up aid)

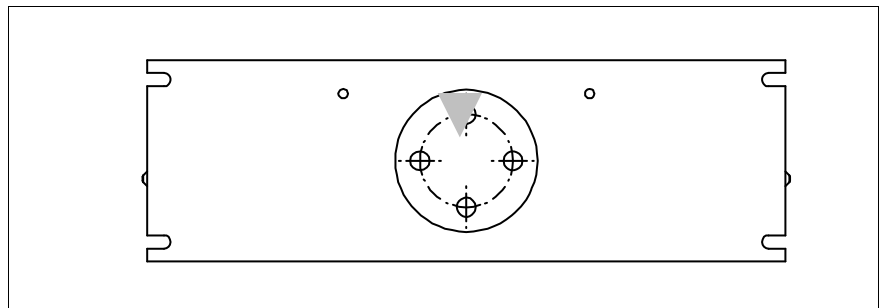

Fig. 9.3 ▼ Home Position bottom view

5.5 To fit the centre column

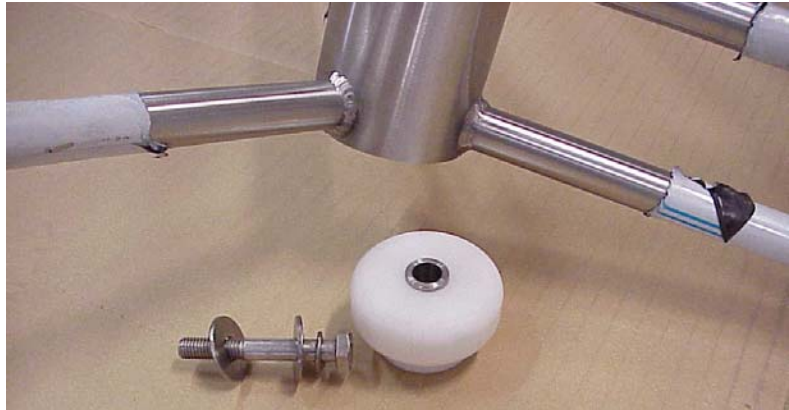

Fig. 10



Fig. 11

Mount the lower bearing on the foundation and stick the centre column on it.



Fig. 12

Fix the centre column by means of the delivered screws M16 at the top flange.
 Make sure the centre is in correct position (centre in locked position).
 (Locking crest in locked position – see drawing)

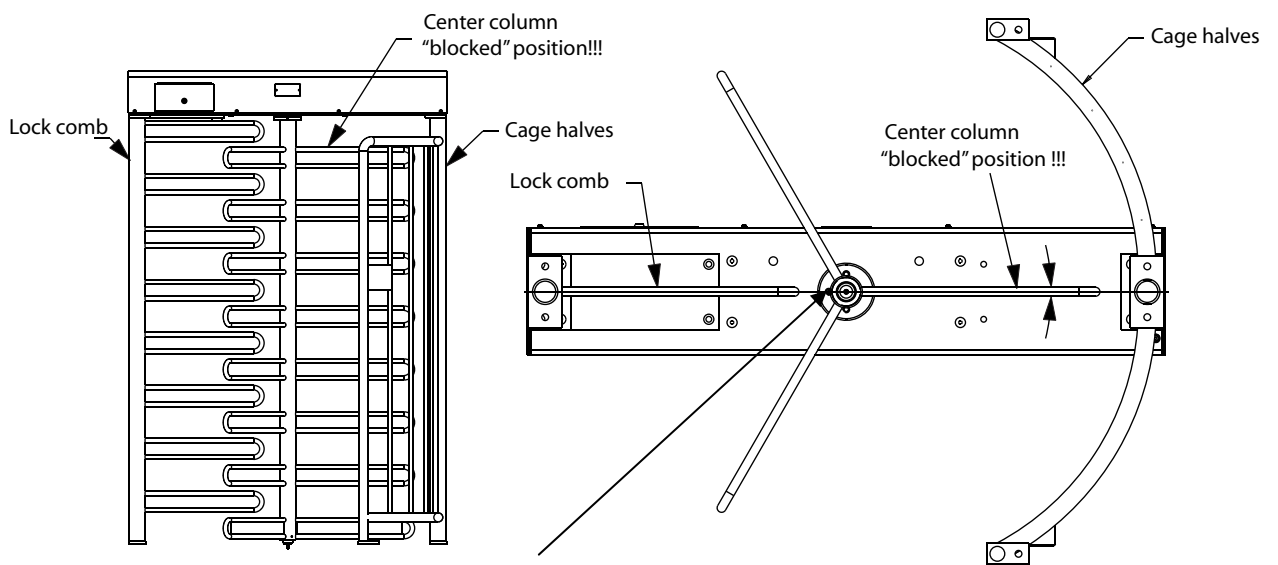

Marking on the flange of the center column is face to face with lock comb!

Fig. 13 Setting the turnstile to the „blocked“ position

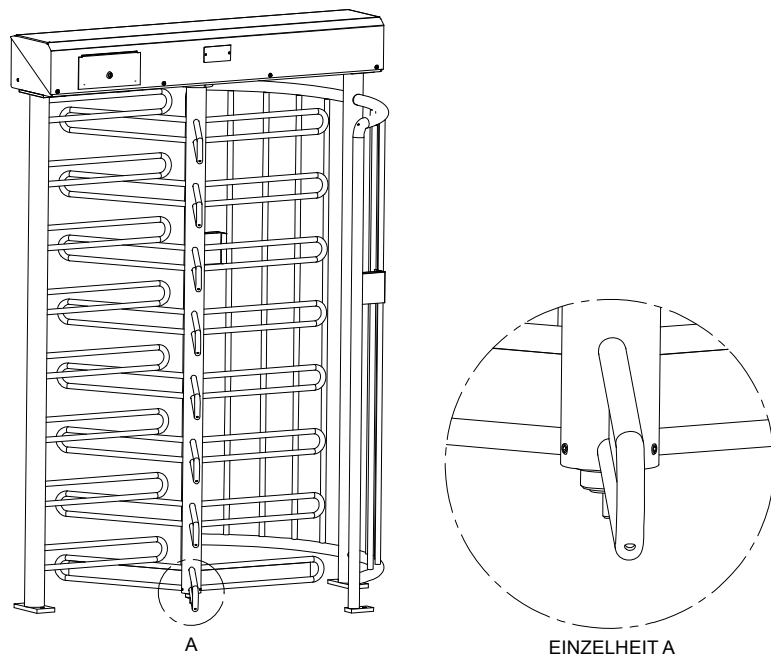

Fig. 13.1

1. Fix the center column to the floor bearing using 3 headless screws.
2. Tighten all 3 headless screws equally, so that the center column can be rotated smoothly in both directions.
3. Secure headless screws using Loctite 241 or similar.

5.6 Assembly of roof with drain

Assemble the roof as shown on Fig.14. The roof can also be mounted rotated by 180°.

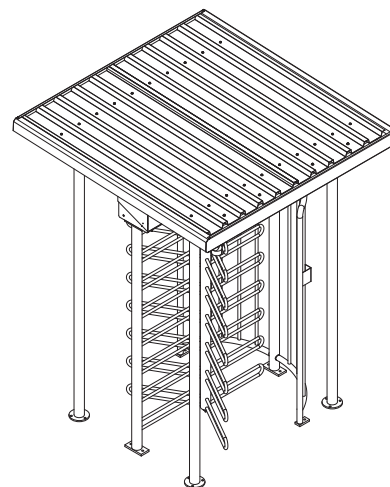
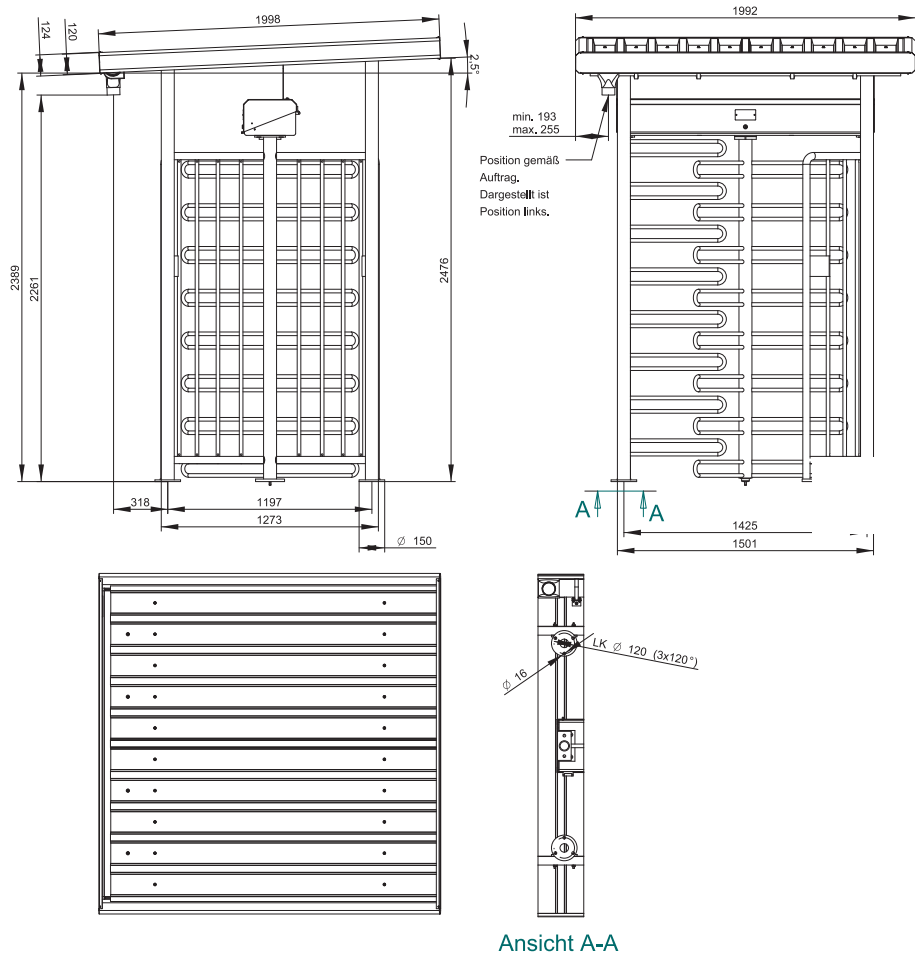

Fig.14

6. Electrical connections

Connection of mains supply should only be performed by a certified electrician and according to the connecting diagram or after discussion with the supplier.
Fig. 16

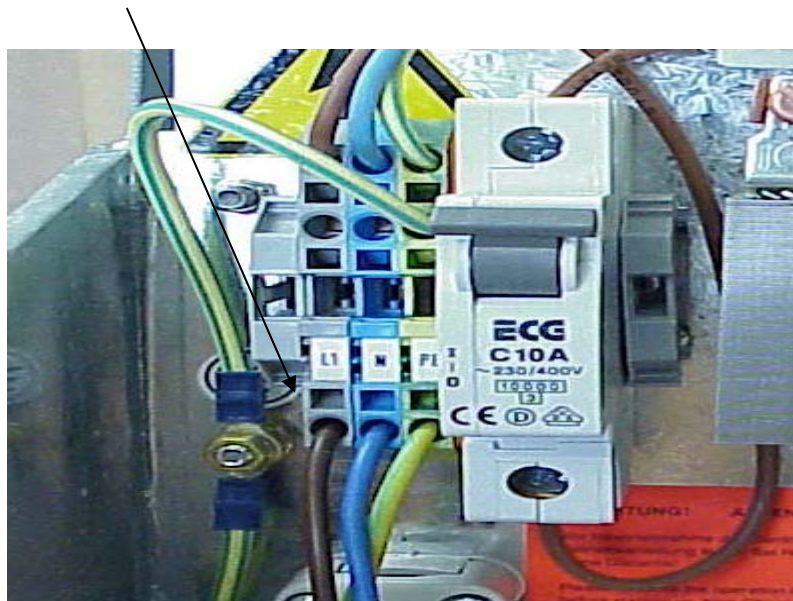

Fig. 15

Connection unit with control unit MSC10

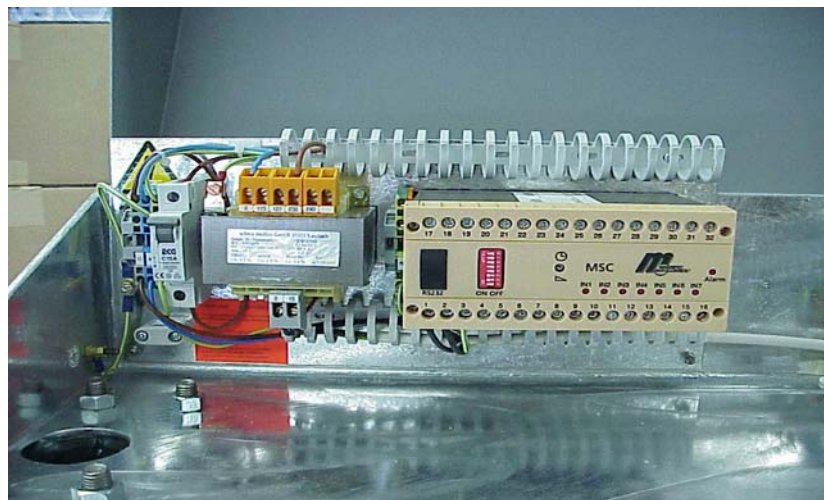

Fig. 16

7. Housings / access control units



Fig.18 Mounting plate for access control devices



Lead the cable from the rear side of the mounting plate to the steel tube and drill the hole.

Here, for example

Fig.19 Rear side



Warning:
Incoming mains supply and connections should only be performed by a certified electrician.

8. Commissioning

Once the mechanical and electrical installation of the turnstile has been completed, it can be put into service.

Check before start-up that all assembly and installation instructions have been followed and the electrical connections have been performed correctly.

8.1 Operation of the Turnstile

The Turnstile is generally operated by an access control system or control switches. Special control panels are also available for operation.

The center column is rotated manually (Center 3 x 120°) and mechanically blocked in either end position.

In order to avoid unauthorized access in opposite direction, the center column is blocked for reverse motion. (Once the center column has been rotated more than 60° in passage direction.)

9. Control Unit MSC 10

Fix adjusted functions

9.1 Functions of the digital inputs

Input 1 = opening – left passage

Opening impulse for single left passage.

Note: The pulse length for single passage may not exceed 1.5 seconds.
If the signal is given for more than 2,5 seconds, the “permanent-free-function” is activated.

Input 2 = Opening - right passage

Opening impulse for single right passage.

Note: The pulse length for single passage may not exceed 1.5 seconds.
If the signal is given for more than 2,5 seconds, the “permanent-free-function” is activated.

Input 3 = Emergency open

Free rotation in either direction in case of emergency

Input 4 = Resource

For future extensions or special programmes.

Input 5 = proximity switch left (normally closed).

Input 6 = proximity switch right (normally open).

Input 7 = Resource input

For future extensions or special programmes.

9.2 Functions of the semiconductor outputs

Output 1 = Control of solenoid (left)

The solenoid which locks the turnstile in left passage direction is connected to output 1.

Output 2 = Control of solenoid (right)

The solenoid which locks the turnstile in right passage direction is connected to output 2.

Output 3 = Resource

For future extensions or special programmes (Not applicable for the first series)

9.3 Functions of the relay outputs

Relay 1 = Counting impulse – left - clamps X17 - X18

With achievement of the end position left in passage direction, this output gives a counting impulse (300ms). This applies also with permanent release.

Relay 2 = Counting impulse – right - clamps X17 - X19

With achievement of the end position right in passage direction, this output gives a counting impulse (300ms). This applies also with permanent release.

Relay 3 = Display “free passage, left” – clamps X20 – X21 - X 22
With free passage in left direction a permanent signal is given on this output.
This output can also be used to block an impulse generator for the right passage direction while left passage is free.

Relay 4 = Display „free passage, right“ - clamps X23 - X24 - X25
With free passage in right direction a permanent signal is given on this output.
This output can also be used to block an impulse generator for the left passage direction while right passage is free.

Relay 5 = Error - / alarm output – clamps - X26 – X27
If certain errors occur, there will be a permanent signal given through this output. This signal will be given until the problem has been solved.

Relay 6 = Resource output
For future extensions or special programmes (Not applicable for the first series)

9.4 Monitoring function

Monitoring function – micro controller
While the gate is in operation, the microcontroller is monitored by watchdog. If the device is not triggered regularly by the microcontroller, the device will perform a hardware reset (watchdog).

Checksum polling
The flash eprom of the microcontroller is read periodically during operation of the turnstile and a checksum polling is carried out.
Should the case arise that single bits change due to external impact, the control unit will switch to a safe operation if this is still possible.
In this case the alarm relay will be switched off (inverted / normally closed contact) and the LED for alarm will be switched on.

Cycle counter
The micro controller counts the number of operation cycles (number of passages) and stores it in the internal memory. Consequently it is possible to proof operation time of the control unit. (e.g. in case of warranty claims)
The customer cannot reset the cycle counter.

No passage counter
If the controller registers a series of 10 opening pulses without following passage, the alarm relay will be activated.
After a valid passage, the alarm relay will be reset.

10. Adjustable parameters

The following parameters can be adjusted by means of DIP switches and the trimming potentiometer:

DIP	Function	OFF	ON
1	Barrier type	MPT	MPP
2	Pulse storage	Off	On = 4 pulses per direction
3	Locking delay time	Off	On = 1 sec.approx.
4	Hardware tests	*)	*)
5	Hardware tests	*)	*)
6	Solenoid left in case of power failure	blocked	free
7	Solenoid right in case of power failure	blocked	free
8	Hold-open-time via LEDs	Not displayed	displayed

DIP 1 Selection of Gate type

This switch has to be set OFF(MPT)

DIP 2 Pulse storage

In case the function is switched OFF, only one demand pulse can be processed. Further pulses are then ignored.

In case the function is switched ON, max. 4 demand pulses per passage direction can be stored.

DIP 3 Locking delay time

The locking delay time can be activated via DIP 3, in order to avoid, that the center column continues its rotation after passage of a person. This we recommend in case of pulse storage (DIP 2 ON) or if one or both directions are permanent free.

DIP 4 / 5 Hardware tests

The settings of these dip switches may only be changed after consultation with Magnetic Autocontrol. Originally, both must be set "OFF".

DIP 6 / DIP 7 "Free" / "locked" in case of power failure

Depending on the requirements of the application in question it is necessary to assure free passage in one or either direction in case of power failure. The mechanical installation and logic control unit of the two solenoids have to be done in accordance with these requirements.

If a passage direction should be blocked in case of power failure, the respective solenoid has to be built-in crosswise to the mounting plate (*Fig.20*). DIP 6 respectively DIP 7 has to be set "OFF" in this case.

If a passage direction should be free in case of power failure, the respective solenoid has to be built-in in the same line as the mounting plate (*Fig.20.1*). DIP 6 respectively DIP 7 has to be set "ON" in this case. DIP 6 controls the left solenoid, whereas DIP 7 controls the right solenoid.



Fig.20



Fig.20.1

DIP 8 Display status of inputs / Display hold-open time

DIP- switch 8 has to be set "OFF" under normal operation conditions. The status of the inputs is shown by the respective LED.

While DIP-switch 8 is set "ON", the hold-open-time is adjustable from 1 – 32 sec. by turning the potentiometer in the front panel of the MSC-controller.

The hold-open-time will be displayed (binary code) by the input LED's IN1 – IN5. LED IN1 shows the lowest significant bit, LED 5 shows the highest significant bit.

Special case: When the potentiometer is turned to the end stop, so that all LED's are off, the hold-open-time is set to unlimited.

The turnstile is out of order, while DIP-switch 8 is set to "ON"!

11 Operation modes

11.1 Bidirectional pulsed operation without impulse storage

If no permanent signal is given to one of the two opening inputs, the turnstile operates in pulsed operation mode in either direction.

Please Note: Open pulse length for single passage may not exceed 1.5 sec..

In this mode you can give an open pulse left or right that gives free the turnstile for one passage. As soon as an opening input has been activated, the hold-open-time begins to count down. At the same time, the output relay of the respective direction is activated to state which passage direction is free. For the opposite direction, the output relay is blocked.

By means of this relay outputs "blocked/free left", respectively "blocked/free right" it is possible, to indicate the free direction. Furthermore, the opposite push button, card reader, coin validator etc., can be blocked while a passage is in process.

If no person begins to pass the turnstile within the pre set hold-open time, the passage will be blocked again. (If, for example, access has been authorised by insert of a coin or token, the coin is lost in this case. To be able to pass the turnstile, a new coin has to be used.)

If the person begins to pass and the center column is out of its home position, the hold-open-time is set to an unlimited period of time.

When the center column is turned over 60°, the hold-open-time will be cleared immediately. Furthermore the center column cannot be turned reverse.

In this mode, any other open pulse will be ignored, as long as the passage is not finished.

11.2 Bidirectional pulsed operation with impulse storage

This operation mode works similar to the “pulsed operation without impulse storage”. The only difference is that the controller can store up to 4 open pulses for each direction and process one after the other.

If open pulses for both directions are stored, both directions are free.

The hold-open-timer begins to count down.

The center column can be operated left or right; independent from the order of the open pulses.

After finishing the passage, the next passage can be started as long as open pulses are stored.

By means of the relay outputs “blocked/free left”, respectively “blocked/free right” it is possible, to indicate the free direction(s).

If the person begins to pass and the center column is out of its home position, the hold-open-time is set to an unlimited period of time.

When the center column is turned over 60°, the hold-open-time will be cleared immediately. Furthermore the center column cannot be turned reverse.

When the locking delay time is activated, the center column will be blocked after each passage for approximately 1 second in its home position, before the next stored pulse can be processed.

This is to avoid, a rotation of more than 120° per passage.

11.3 Permanent free in both directions.

If both inputs, IN1 and IN2 are switched by permanent contact (>2.5 s), passage is free for both directions.

In case permanent contact is given to the inputs in pulsed operation mode, stored opening pulses will be cleared.

If the locking delay time is activated, the center column will be blocked for approximately 1 second in its home position, after each passage.

This is to avoid a rotation of more than 120° per passage.

When the permanent-open-contact (>2.5s) is switched off, the gate will be blocked immediately. There is no hold-open-time active.

11.4 Pulsed operation in one -, permanent free in the other direction.

If a permanent contact (or wire bridge) is connected to one of the inputs IN1 or IN2, the respective direction is set to free passage.

In the opposite direction, the turnstile works in pulsed operation mode.

In case permanent contact (>2.5s) is given to an input in pulsed operation mode, stored opening pulses will be cleared for the respective direction.

If the locking delay time is activated, the center column will be blocked for approximately 1 second in its home position, after each passage.

This is to avoid a rotation of more than 120° per passage.

When the permanent-open-contact (>2.5s) is switched off, the gate will be blocked immediately. There is no hold-open-time active.

12. Technical Support

Our customer service can be contacted for any technical advice.

Information about the responsible contact person can be retrieved by telephone, fax, E-mail or via the Internet at any time, refer to manufacturer's address on Page 2.



NOTE!

In order to enable fast handling note the data of the type plate such as type, serial number, version etc. before calling.

13. Spare parts and accessories

See Figure 14 for the exploded drawing which details the individual parts and their identification numbers.

Spare parts

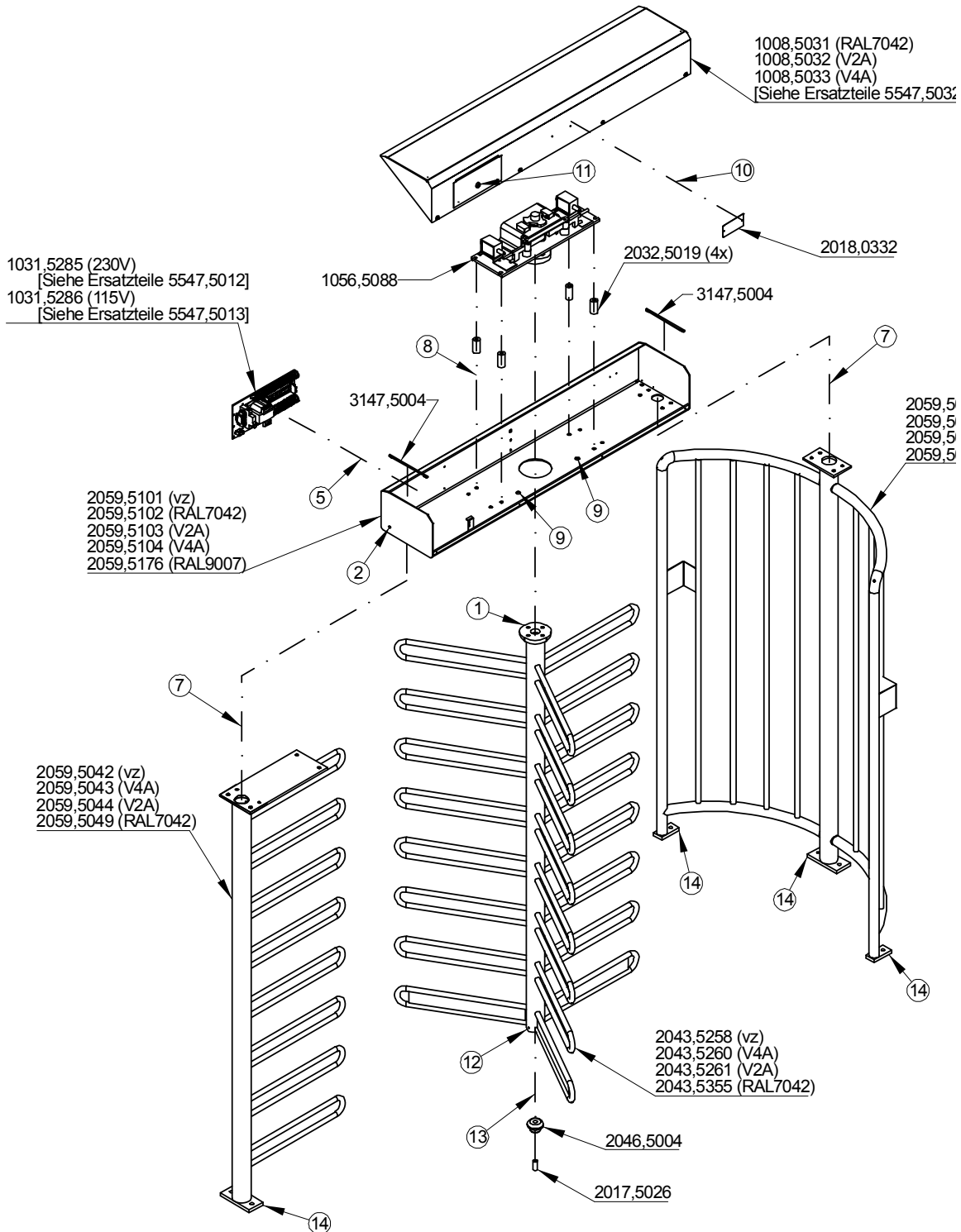

Fig.21

Spare parts

Small parts (without picture)

Application field:	Art.-Nr.	Name
1	3486,5010	Hexagon screw M16x40 (SS 304)
1	3498,0018	Washer M16 (SS 304)
2	3306,0007	Hexagon nut M5 (brass)
2	3490,5003	Countersunk screw with internal hexagon M5x25 (SS 304)
2	3495,0006	Toothed lock washer M5 (SS 304)
2	3498,0020	Washer M5 (brass)
2	3513,0009	Safety ring M5 (SS 304)
5	3306,0033	Hexagon nut M5 (SS 304)
5	3307,0008	Fixing nut M5 (SS 304)
5	3490,5003	Countersunk screw with internal hexagon M5x25 (SS 304)
5	3500,0014	Large diameter washer M5 (SS 304)
7	3307,5000	Fixing nut M12 (SS 304)
7	3490,5007	Countersunk screw with internal hexagon M12x35 (SS 304)
8	3307,5000	Fixing nut M12 (SS 304)
8	3490,5008	Countersunk screw with internal hexagon M12x100 (SS 304)
8	3500,5000	Large diameter washer M12 (SS 304)
9	3576,5019	Sealing plug
10	3330,0014	Blind rivet d3x8 (Aluminium)
11	3466,0019	Key
12	3138,0040	Set screw M8x8 (SS 304)
13	3098,5000	Spring ring M10 (SS 304)
13	3469,5017	Internal thread tie bar M10 (SS 316)
13	3469,5018	Glue cartridge
13	3485,5014	Hexagon screw M10x70 (SS 304)
13	3500,5006	Large diameter screw M10 (SS 304)
14	3098,5000	Spring ring M10 (SS 304)
14	3469,5017	Internal thread tie bar M10 (SS 316)
14	3469,5018	Glue cartridge
14	3486,5001	Hexagon screw M10x35 (SS 304)
14	3500,5006	Large diameter washer M10 (SS 304)

14. Setting of limit switches

The limit switches are factory set.

In case of a necessary replacement of the limit switches, the settings have to be made according to the drawing.

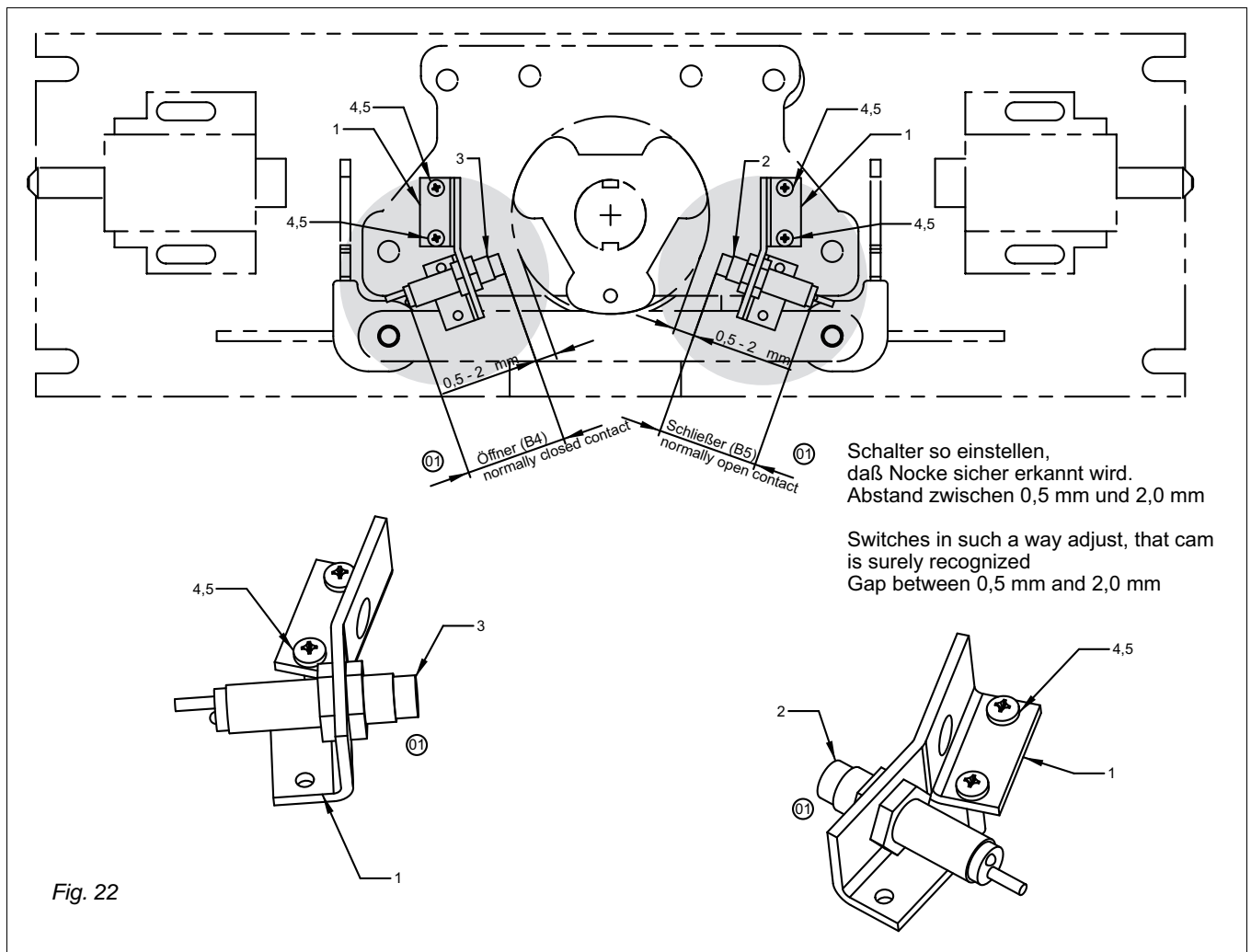

15. Warranty conditions

Subject to the condition that the operating instructions are observed, and that no inadmissible operations are carried out on the technical equipment, and that the installation has suffered no mechanical damage, MAGNETIC guarantees all mechanical and electrical components for the duration as stated in our standard terms of sales and delivery or as contractually agreed in writing.

16. Decommissioning



RECYCLING!

The relevant regional regulations and laws considering disposal of substances, materials and machine parts have to be adhered. Recyclable parts have to be handed over to specialized collection stations!

In order to sustain a clean environment it is essential to handle all materials with care and to assure a disposal that causes the smallest possible harm to the environment.

Packing material

After unpacking of device and accessories please dispose of the packing material using the separate collection.

Device

When disposing of the device or parts of it at the end of utilisation ensure those noxious and dangerous residues are disposed of in accordance with the regulations. Based on the different material, disposal must occur in a separate manner.

Electric and electronic parts

Please note, that electric and electronic parts may contain plastic and toxic substances and therefore have to be collected and disposed of as hazardous waste!



NOTE!

To ensure a professional disposal of electric and electronic parts you may consult MAGNETIC or a competent electrician.

Lubricants and operating fluids

Lubricants and operating fluids (e.g. oil, grease, etc.) have to be stored safely and must not escape uncontrolled into the environment.



WARNING!

It is forbidden to dispose of flammable materials with the domestic waste collection!

MAGNETIC Autocontrol GmbH
Grienmatt 20
D - 79650 Schopfheim
Germany

Tel.: +49 7622 695 5
Fax: +49 7622 695 602
eMail: info@ac-magnetic.com
www.ac-magnetic.com