

J355HA M30-P1

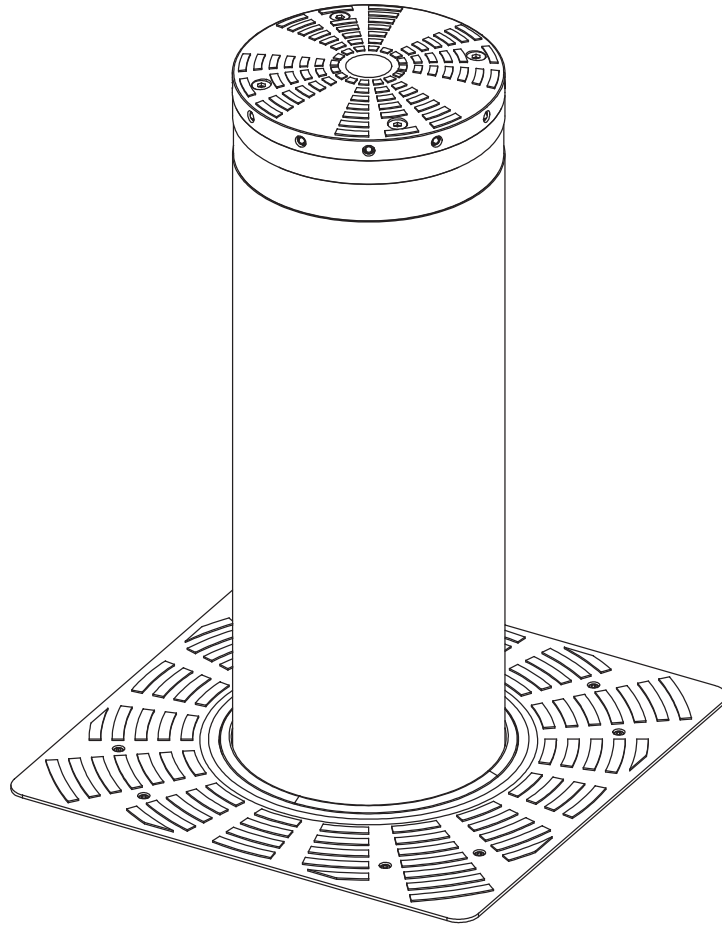

FAAC

© Copyright FAAC S.p.A. dal 2015. Tutti i diritti riservati.

Nessuna parte di questo manuale può essere riprodotta, archiviata, distribuita a terzi né altrimenti copiata, in qualsiasi formato e con qualsiasi mezzo, sia esso elettronico, meccanico o tramite fotocopia, senza il preventivo consenso scritto di FAAC S.p.A.

Tutti i nomi e i marchi citati sono di proprietà dei rispettivi fabbricanti.

I clienti possono effettuare copie per esclusivo utilizzo proprio.

Questo manuale è stato pubblicato nel 2015.

© Copyright FAAC S.p.A. from 2015. All rights reserved.

No part of this manual may be reproduced, archived, distributed to third parties nor copied in any other way, in any format and with any means, be it electronic, mechanical or by photocopying, without prior written authorisation by FAAC S.p.A.

All names and trademarks mentioned are the property of their respective manufacturers.

Customers may make copies exclusively for their own use.

This manual was published in 2015.

© Copyright FAAC S.p.A. depuis 2015. Tous droits réservés.

Aucune partie de ce manuel ne peut être reproduite, archivée ou distribuée à des tiers ni copiée, sous tout format et avec tout moyen, qu'il soit électronique, mécanique ou par photocopie, sans le consentement écrit préalable de FAAC S.p.A.

Tous les noms et les marques cités sont la propriété de leurs fabricants respectifs.

Les clients peuvent faire des copies pour leur usage exclusif.

Ce manuel a été publié en 2015.

© Copyright FAAC S.p.A. ab dem 2015. Alle Rechte vorbehalten.

Kein Teil dieses Handbuchs darf reproduziert, gespeichert, an Dritte weitergegeben oder sonst auf eine beliebige Art in einem beliebigen Format und mit beliebigen Mitteln kopiert werden, weder mit elektronischen, noch mechanischen oder durch Fotokopieren, ohne die Genehmigung von FAAC S.p.A.

Alle erwähnten Namen und Marken sind Eigentum der jeweiligen Hersteller.

Die Kunden dürfen nur für den Eigengebrauch Kopien anfertigen.

Dieses Handbuch wurde 2015 veröffentlicht.

© Copyright FAAC S.p.A. del 2015. Todos los derechos están reservados.

No puede reproducirse, archiversse, distribuirse a terceros ni copiarse de ningún modo, ninguna parte de este manual, con medios mecánicos o mediante fotocopia, sin el permiso previo por escrito de FAAC S.p.A.

Todos los nombre y las marcas citadas son de propiedad de los respectivos fabricantes.

Los clientes pueden realizar copias para su uso exclusivo.

Este manual se ha publicado en 2015.

© Copyright FAAC S.p.A. van 2015. Alle rechten voorbehouden.

Niets uit deze handleiding mag gereproduceerd, gearchiveerd, aan derden openbaar gemaakt of op andere wijze gekopieerd worden, in om het even welke vorm en met geen enkel middel, noch elektronisch, mechanisch of via fotokopiëren, zonder schriftelijke toestemming vooraf van FAAC S.p.A.

Alle vermelde namen en merken zijn eigendom van de respectievelijke fabrikanten.

De klanten mogen kopieën maken die enkel voor eigen gebruik bestemd zijn.

Dez handleiding werd in 2015 gepubliceerd.



FAAC S.p.A. Soc. Unipersonale

Via Calari, 10 - 40069 Zola Predosa BOLOGNA - ITALY

Tel. +39 051 61724 - Fax +39 051 758518

www.faac.it - www.faacgroup.com

CE DECLARATION OF CONFORMITY FOR MACHINES

(DIRECTIVE 2006/42/EC)

Manufacturer: FAAC S.p.A.
 Address: Via Calari, 10 - 40069 Zola Predosa BOLOGNA - ITALY
 Declares that: The operator mod. J355HA M30-P1

is built to be integrated into a machine or to be assembled with other machinery to create a machine under the provisions of Directive 2006/42/EC

conforms to the essential safety requirements of the following EEC directives

2006/95/EC Low Voltage Directive
 2004/108/EC Electromagnetic Compatibility Directive

and also declares that it is prohibited to put into service the machinery until the machine in which it will be integrated or of which it will become a component has been identified and declared as conforming to the conditions of Directive 2006/42/EEC and subsequent amendments.

Bologna, 01st January 2015

CEO
 A. Marcellan



ENGLISH

Translation of the original instructions

WARNINGS FOR THE INSTALLER

GENERAL SAFETY OBLIGATIONS

1. ATTENTION! To ensure the safety of people, it is important that you read all the following instructions. Incorrect installation or incorrect use of the product could cause serious harm to people.
2. Carefully read the instructions before beginning to install the product.
3. Do not leave packing materials (plastic, polystyrene, etc.) within reach of children as such materials are potential sources of danger.
4. Store these instructions for future reference.
5. This product was designed and built strictly for the use indicated in this documentation. Any other use, not expressly indicated here, could compromise the good condition/operation of the product and/or be a source of danger.
6. FAAC declines all liability caused by improper use or use other than that for which the automated system was intended.
7. Do not install the equipment in an explosive atmosphere: the presence of inflammable gas or fumes is a serious danger to safety.
8. FAAC is not responsible for failure to observe Good Technique in the construction of the closing elements to be motorised, or for any deformation that may occur during use.
9. Installation must be performed in compliance with current Standards.
10. Before attempting any job on the system, cut out electrical power.
11. The mains power supply of the automated system must be fitted with an all-pole switch with contact opening distance of 3 mm or greater. Use of a 6A thermal breaker with all-pole circuit break is recommended.
12. Make sure that a differential switch with threshold of 0.03 A is fitted upstream of the system.
13. Make sure that the earthing system is perfectly constructed and connect metal parts of the closure to it.
14. The automated system is supplied with an intrinsic anti-crushing safety device consisting of a torque control. Nevertheless, its tripping threshold must be checked as specified in the Standards indicated at point 10.
15. The safety devices (EN 12978 standard) protect any danger areas against mechanical movement Risks, such as crushing, dragging, and shearing.
16. Use of at least one indicator-light (i.e. flashing lamp incorporated in the bollard head) is recommended for every system, as well as a warning sign adequately secured.
17. FAAC declines all liability as concerns safety and efficient operation of the automated system, if system components not produced by FAAC are used.
18. For maintenance, strictly use original parts by FAAC.
19. Do not in any way modify the components of the automated system.
20. The installer shall supply the user with the necessary information for the manual operation of the system in the event of emergency.
21. Do not allow children or adults to stay near the product while it is operating.
22. Keep remote controls or other pulse generators away from children, to prevent the automated system from being activated involuntarily.
23. Transit on the bollard is permitted only when the device is completely down.
24. The user must not attempt any kind of repair or direct action whatever and contact qualified personnel only.
25. Anything not expressly specified in these instructions is not permitted.

CONTENTS

1. J355HA M30-P1 BOLLARD	4	2.7 EFO (optional)	12
1.1 General notes	4	2.8 Manual release (optional)	12
1.2 Description and technical specifications	4	2.9 Automatic operation	12
1.3 Dimensions	5	2.10 Maintenance	12
2. INSTALLATION	6	3. JE275 CONTROL UNIT	13
2.1 Facilities	6	3.1 Electrical connections	13
2.2 Preparing the foundation cage	7	3.2 Pre-setting selection	13
2.3 Securing the pit	8	3.3 Connection of several bollards (master/slave)	14
2.4 Electric wiring	10	3.4 Troubleshooting	15
2.5 Inserting the bollard in the pit	11	4. PERFORMING MAINTENANCE ON THE EFO SYSTEM	15
2.6 Fastening the top crown	11		

1. J355HA M30-P1 BOLLARD



Please read with the utmost care this manual supplied with the product, since it contains important indications about safety, installation, use and maintenance.

1.1 GENERAL NOTES

These instructions apply to model

J355HA M30-P1

This model refers to anti-terrorist automatic hydraulic traffic bollards. The cylinder is driven by a two-motor hydraulic unit fixed inside the structure.

1.2 DESCRIPTION AND TECHNICAL SPECIFICATIONS

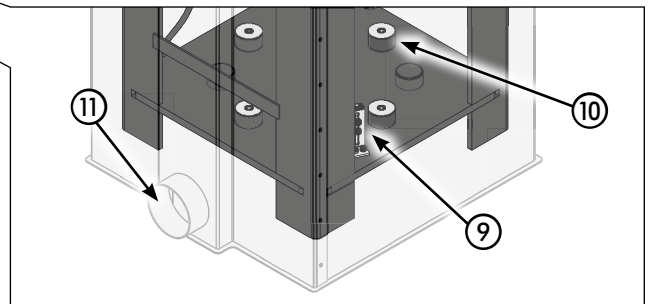
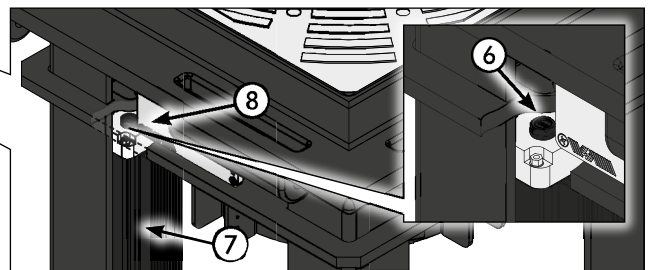
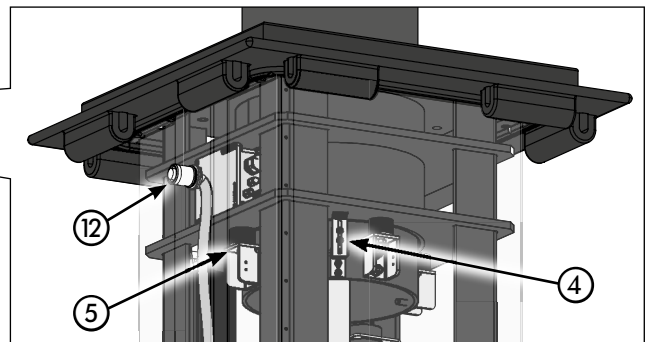
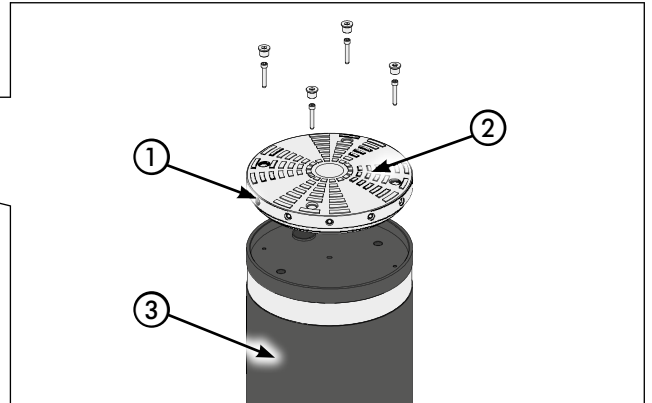
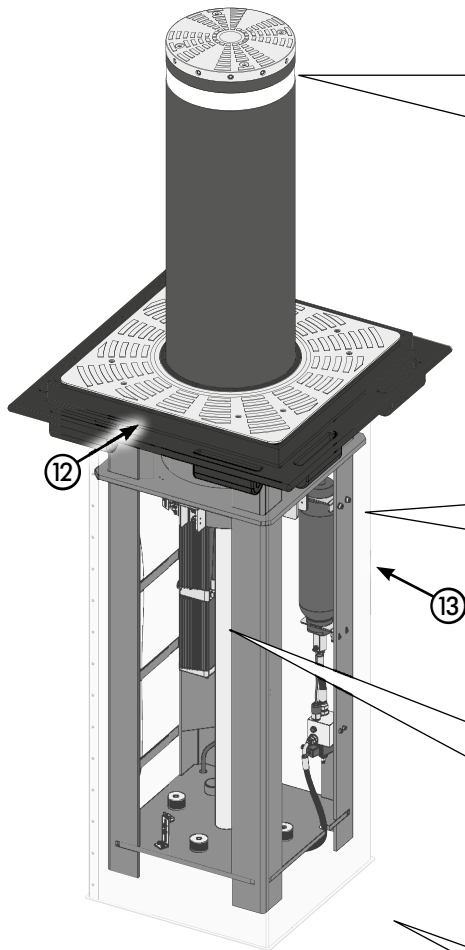

- 1 LED Flashing lamp
- 2 Crown
- 3 Cylinder
- 4 Magnetic contacts, up (N.C. polarity)
- 5 4 stop points, up
- 6 Oil filler plug with level rod
- 7 Two-motor hydraulic unit
- 8 Junction box
- 9 Magnetic contact, down (N.C. polarity)
- 10 4 stop points, down
- 11 Ø 100 mm hole for draining or pump connection
- 12 Cable routing hole
- 13 Foundation pit

1 Tab.A - Technical specifications

MODEL	J355HA M30-P1
Power supply	230 V~ (+6% -10%) 50 (60) Hz
Max. absorbed power (W)	2800
Max. force (N)	5000
Max. pump delivery (lpm)	6
Minimum lifting time (sec)	6
Minimum lifting time (using EFO) (sec)	1,5
Minimum lowering time (sec)	2
Operating ambient temperature (°C)	-15 ÷ +55
Weight bollard and pit (kg)	490 (bollard) 250 (pit)
Oil quantity (l) (1)	3
Protection class	IP66
Overall dimensions	See Fig.2
Capacitor (2)	2 x 20µF - 400V
Burglar-proofing (J) (3)	656000



- (1) check the oil level using the rod attached to the filler plug (Fig. 1 ref. ⑥) with the piston rod completely retracted and pressurised EFO system.
- (2) The two thrust capacitors (20yF - 400v) can be pre-loaded inside the junction box (see Fig. 13).
- (3) certified under ASTM F2656-07 CLASS M30-P1



1.3 DIMENSIONS

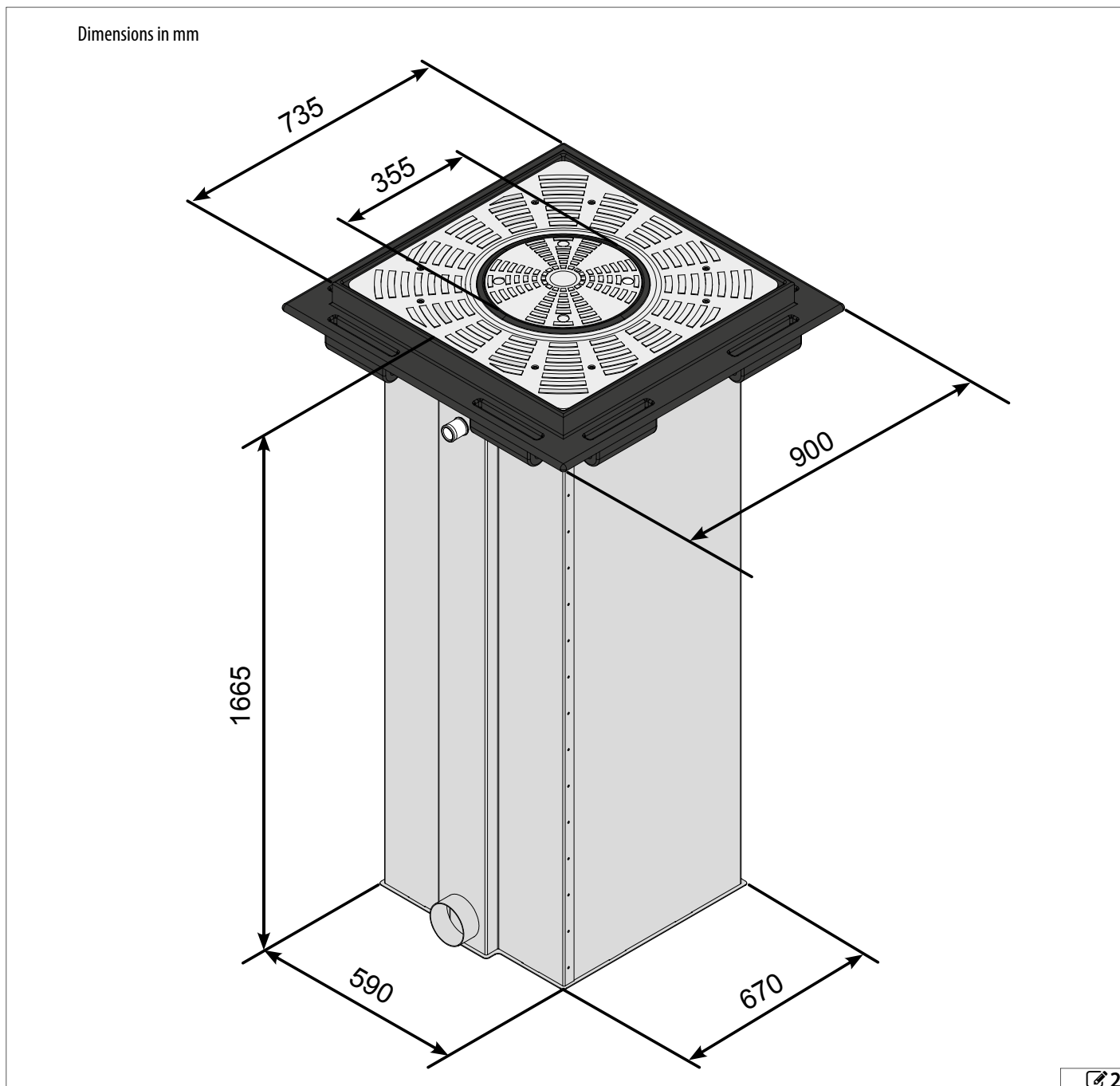

2. INSTALLATION

2.1 FACILITIES

i For draining, use a \varnothing 100 flexible tube. Dig up to a depth of about 1.8 m

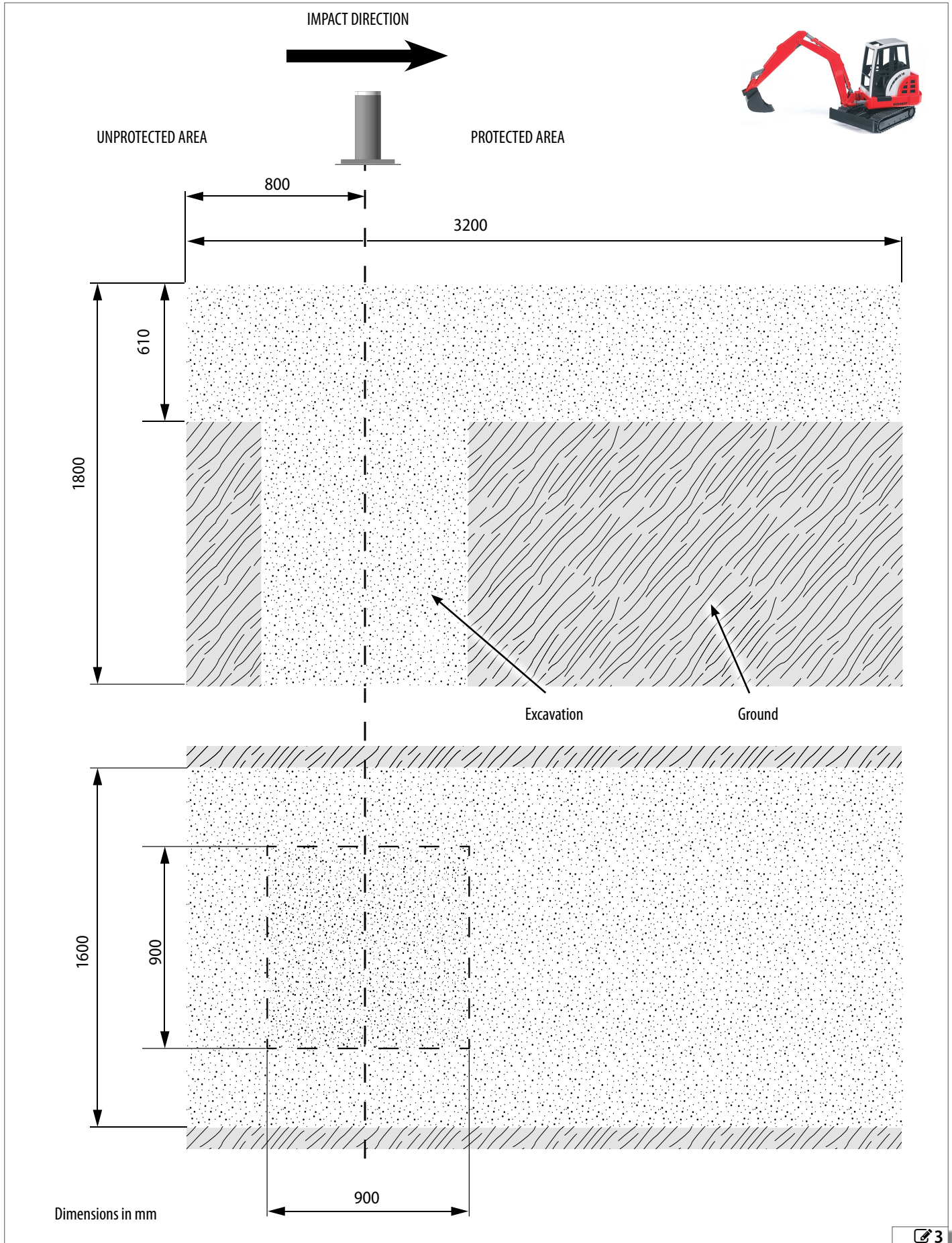

2.2 PREPARING THE FOUNDATION CAGE

Prepare the foundation cage (not supplied by us) as shown in the figure below using $\varnothing 12$ mm iron rods CLASS B450C

Dimensions in mm

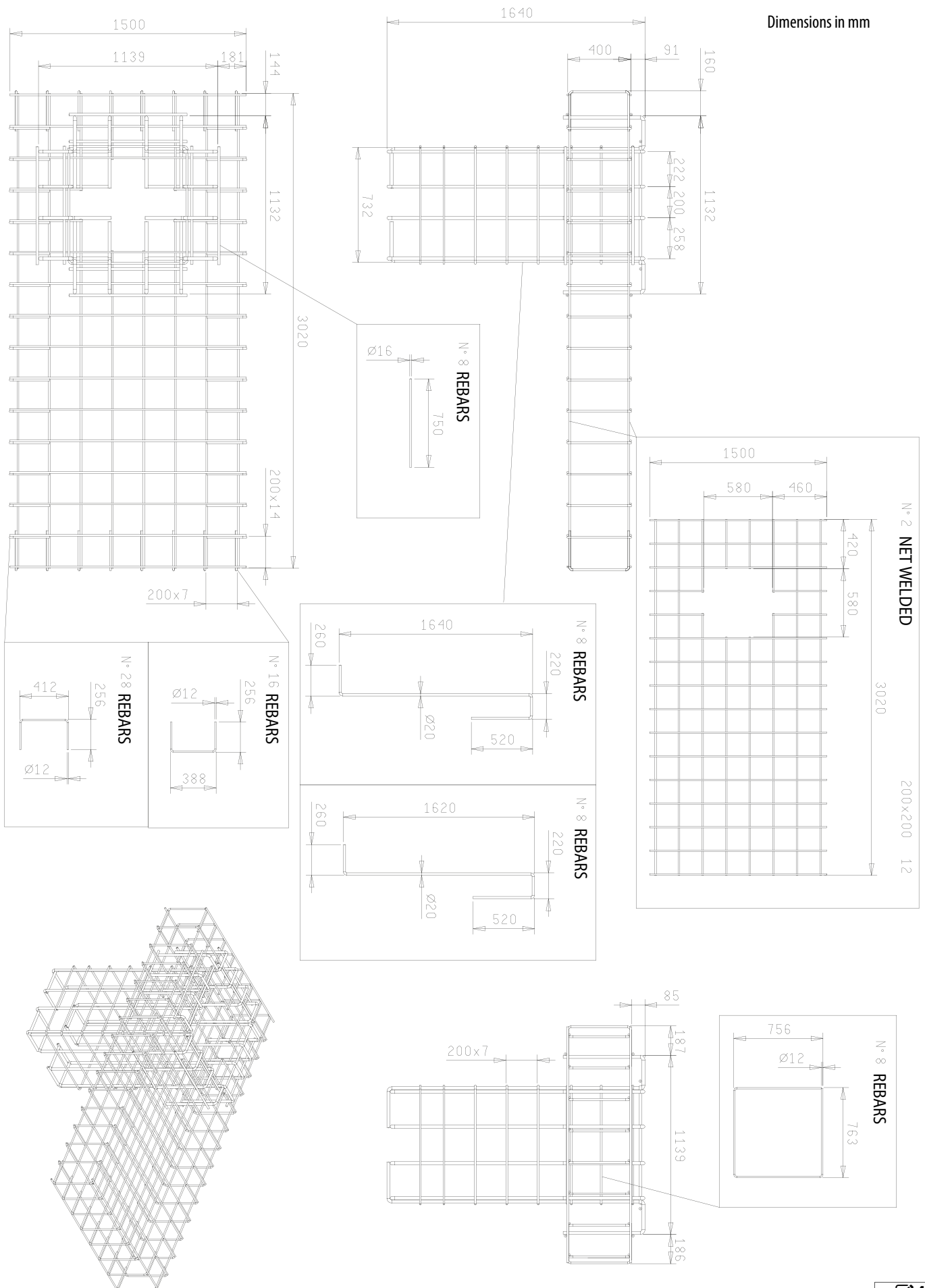

2.3 SECURING THE PIT

Once the foundation cage is completed, secure the counter-frame to the pit plate using the M10x25 screws, as shown in Fig. 5.

Then, place the pit in the cage as shown in Fig. 6, and carefully weld the 4 rods 760mm - Ø 16mm (ref. ① in Fig. 6) to the cage

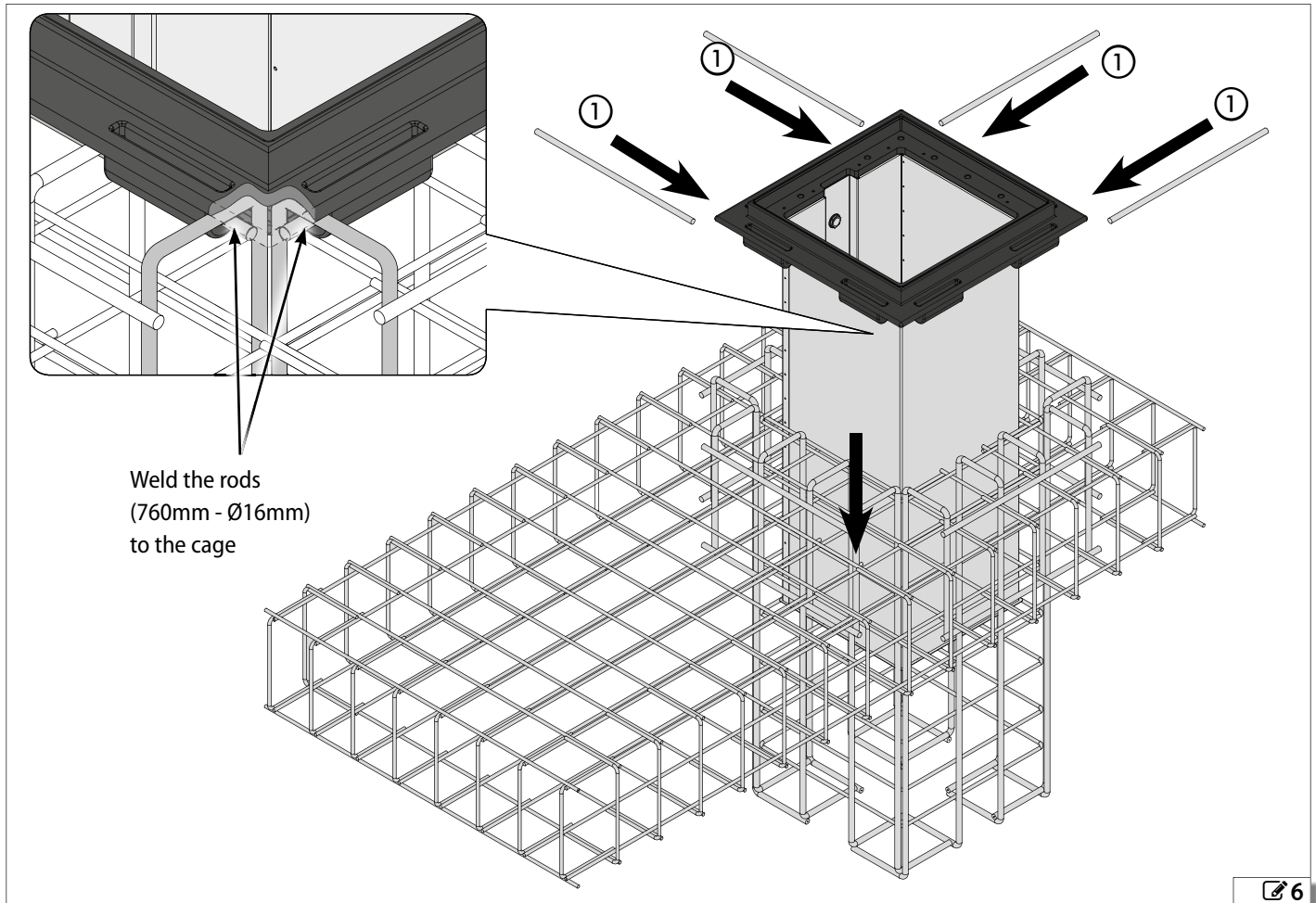
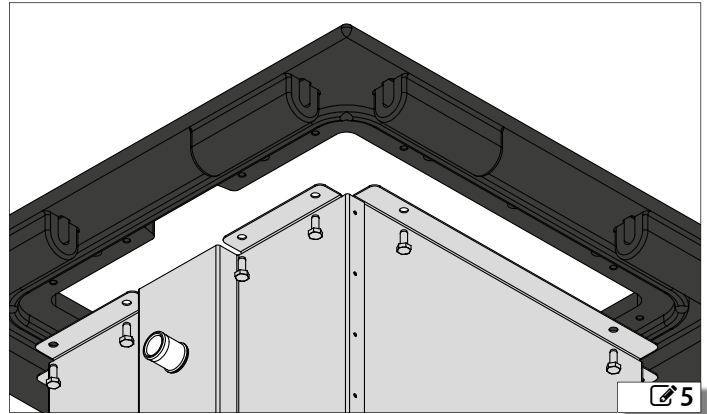

Weld the rods (760mm - Ø16mm) to the cage



Place the thus composed metal cage in the dug-out area, and ensure that it is plumb. The upper level of the counter-frame must be approximately 10 mm higher than the tread, as shown to the right (to limit entry of rainwater in the pit).

After installation of the pit, lay a flexible sheath, internal diameter 45mm, from the connection in the metallic pit to the drive control station (see Fig. 7).

Pour class C25/30 concrete all around the cage to secure it properly, up to approximately 10 cm from the tread area. Wait at least 7 days for the concrete to set correctly and finish the road surface using the same type of material.

Lay the pipelines, that are necessary for the connection between the control unit and any additional device, if any. Prepare the electrical connection and the earthing.

To connect the bollard to the control board, use a cable, type **FG70R-0,6/1kV-16G1,5**, having a **max. length of 50 m.**

N.B.: every pipe must be laid in compliance with the current rules.

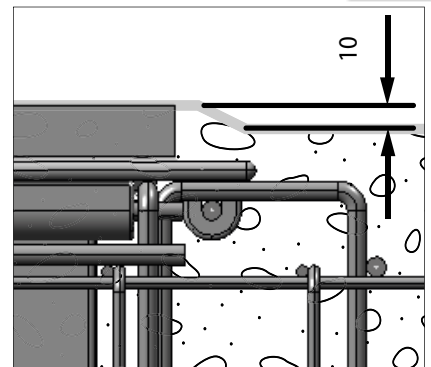

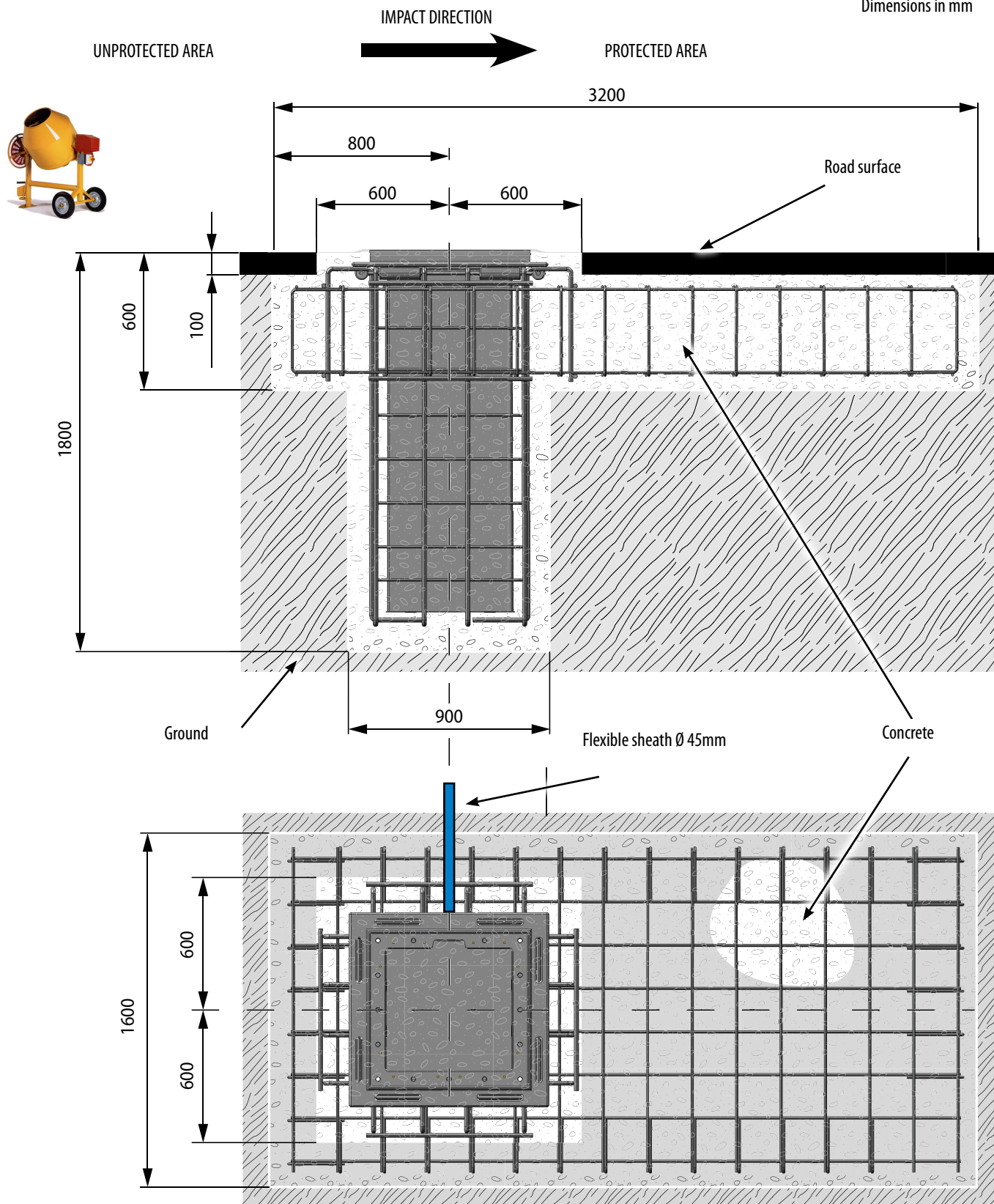

The foundation concrete can be poured directly into the dug-out area.

Concrete specifications:

- A. Class C25/30.
- B. Concrete with 10-30 aggregate according to UNI EN 12620 standard
- C. The bollard must be installed after at least 7 days of concrete setting.

The compacting index of the surrounding ground must be at least 90% of the "Proctor" optimum curve, according to UNI EN 13286-2:2005 standard.

The steel framework must comply with class B450C (ASTM A615 Grade 60).

During the concrete maturation phase, insert one or more contrast supports inside the pit to prevent inwards deformation of the walls due to pushing by the fresh concrete.

2.4 ELECTRIC WIRING

For the connection of the bollard to the control unit, use a multi-pole cable, type **FG70R-0,6/ kV- 16G 1.5 (16 cables of 1.5mm²) with max. length of 50 m**. This cable must be laid inside a sheath \varnothing 45mm, secured to the cable clamp in the bottom part of the frame (fig. 8 ref. ①) and must come out of the pit by 2.5 m.

Perform the electric wiring in the junction box on the bollard side, as shown in Fig. 13.



Any additional accessory (i.e. photocells, opening/closing push-buttons, etc.), that have to be connected to the control unit, must compulsorily have double insulation.

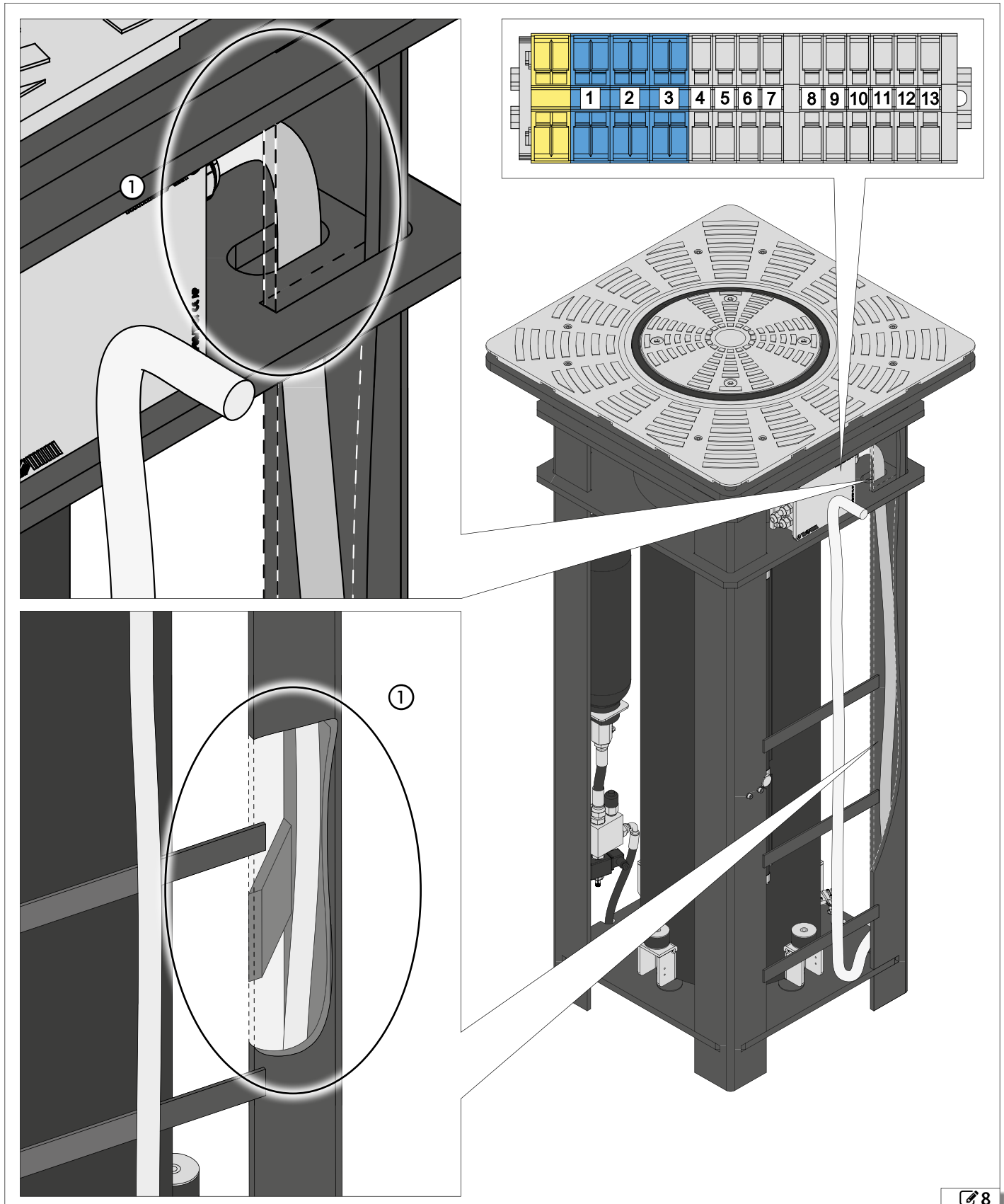

ENGLISH
Translation of the original instructions

2.5 INSERTING THE BOLLARD IN THE PIT

To place the bollard in the previously prepared pit (wait at least 7 days for the cement to set), you must screw two eyebolts M20 on the top part, as shown in the figure below, using them as hooking points for the lifting operation with belts or chains.

- i** Before inserting the bollard in the pit, wire as described in the previous chapter and check its correct operation, also checking the correct intervention of the safety devices (see "JE275 ELECTRONIC EQUIPMENT" on page 11).

Lift and insert completely the bollard in the pit.

- i** During this phase ensure the cable is positioned correctly to prevent it from being crushed between the pit and the bollard frame.

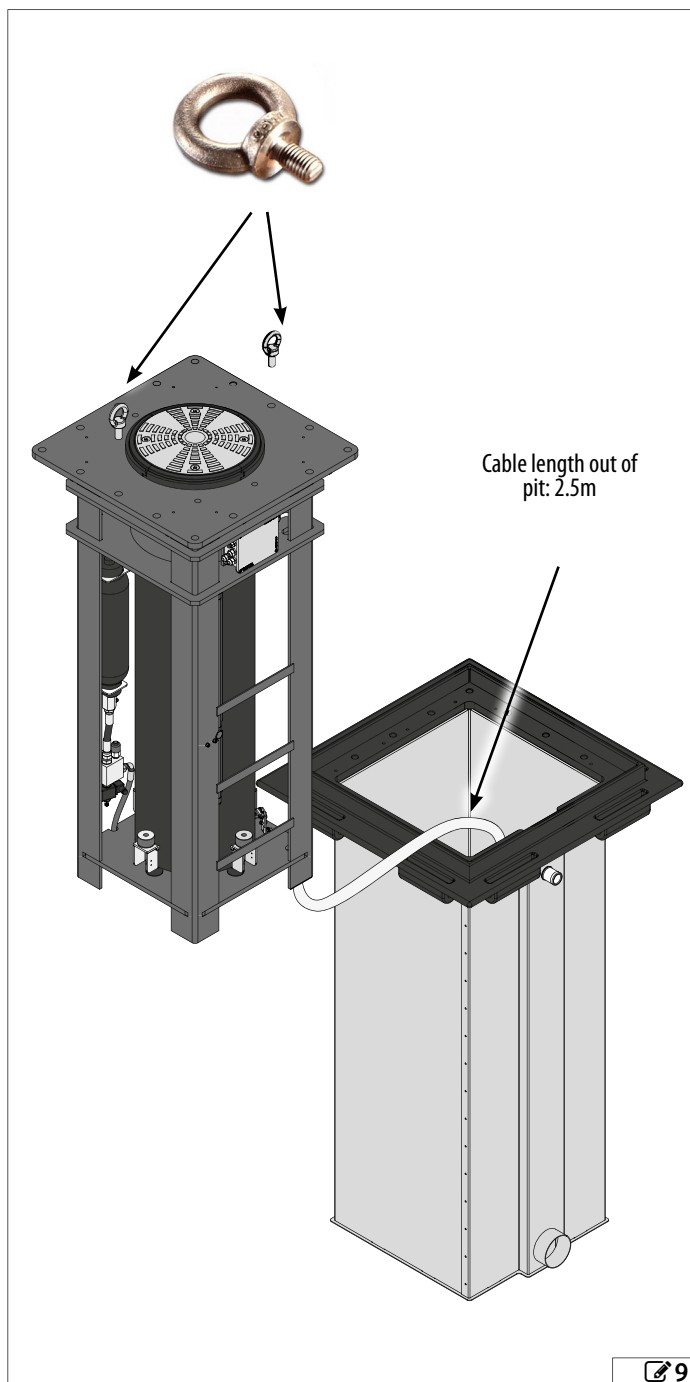

After completely inserting the bollard and resting it on the pit counter-frame, remove the two eyebolts and secure the bollard to the pit using the 15 provided cylindrical head screws with hexagon socket M20x45.

- i** **IMPORTANT:**
TIGHTEN THE 15 SCREWS USING **200Nm** TORQUE

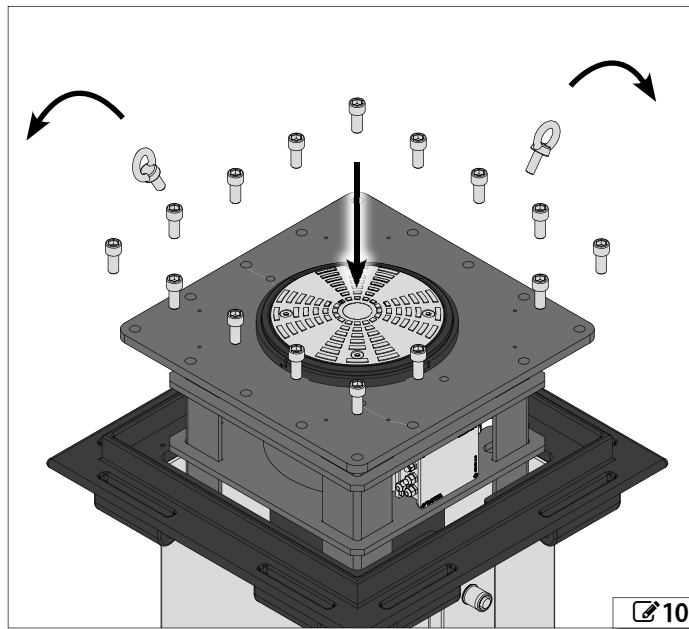

2.6 FASTENING THE TOP CROWN

After having secured the bollard, complete the installation positioning and securing the top crown with 8 cylindrical head screws with hexagon socket M8x30 INOX supplied standard

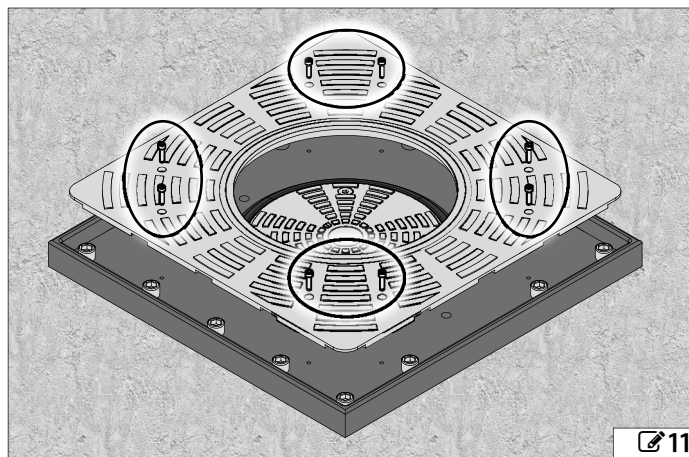

2.7 EFO (OPTIONAL)

The J355HA M30-P1 bollard can be equipped with an Emergency Fast Operation "EFO" that can be activated at any time to command immediate rising of the automation. The EFO system consists of a tank, a pressure switch and a control solenoid valve powered at 230 V ~ For connection of the solenoid valve (different depending on the N.O. / N.C. option used), refer to Fig. 13, terminals 4 and 5.

The N.O. solenoid valve allows activation of the EFO if commanded by the operator or in the event of a power failure, whilst the N.C. version only allows voluntary activation of the device.

2.8 MANUAL RELEASE (OPTIONAL)

To manually lower the bollard, use the release device following the instructions below.

1. Loosen and remove the 8 cylindrical head screws with hexagon socket M8x30 securing the upper crown (Fig. 12 ref. ①).
2. Remove the upper crown (Fig. 12 ref. ②).
3. Insert the key supplied in the hole and rotate it one turn anticlockwise to lower the bollard (Fig. 12 ref. ③).

2.9 AUTOMATIC OPERATION

To restore the automatic operation:

1. Insert the key in the hole and rotate clockwise all the way down.
2. Refit the upper crown.
3. Tighten the 8 cylindrical head screws with hexagon socket M8x30 securing the upper crown.

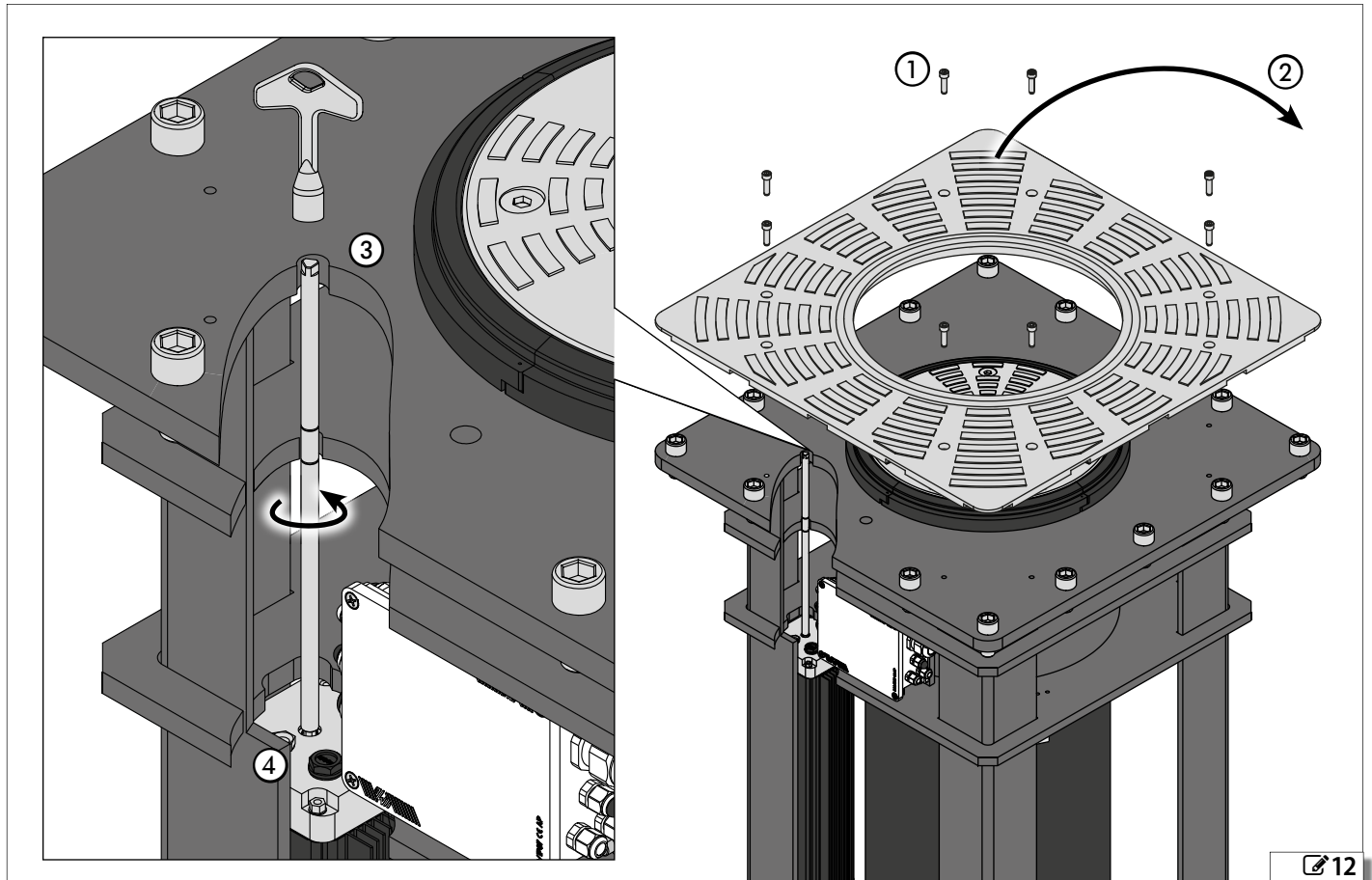

2.10 MAINTENANCE

The standard routine maintenance sequence is as follows:

1. Clean the pit using vacuum for deposited materials
2. Clean the drained water at the bottom of the pit
3. Check (and, if necessary, replace) the lower stop gaskets
4. Check and, if necessary, repair any oil leaks affecting the drive piston
5. Check that all the bollard screws are correctly tightened
6. Clean the drive cylinder and, if necessary, touch up the paintwork
7. Check the hydraulic unit; top up the oil, if necessary
8. Verify that the EFO system works correctly

3. JE275 CONTROL UNIT



Always cut the power supply before performing any intervention on the control unit (connections, maintenance).

Install a differential thermal-magnetic switch with suitable threshold (0.03A) upstream of the system.

Connect the earth cable to the relevant terminal on the connector J9 of the unit (see figure below).

Ensure that the grid disconnect switch has a lock key, unless it is installed in view of the operator/maintenance technician.



The equipment must be laid at a height ranging between 0.4 m and 2.0 m.

3.1 ELECTRICAL CONNECTIONS

ENGLISH

Translation of the original instructions

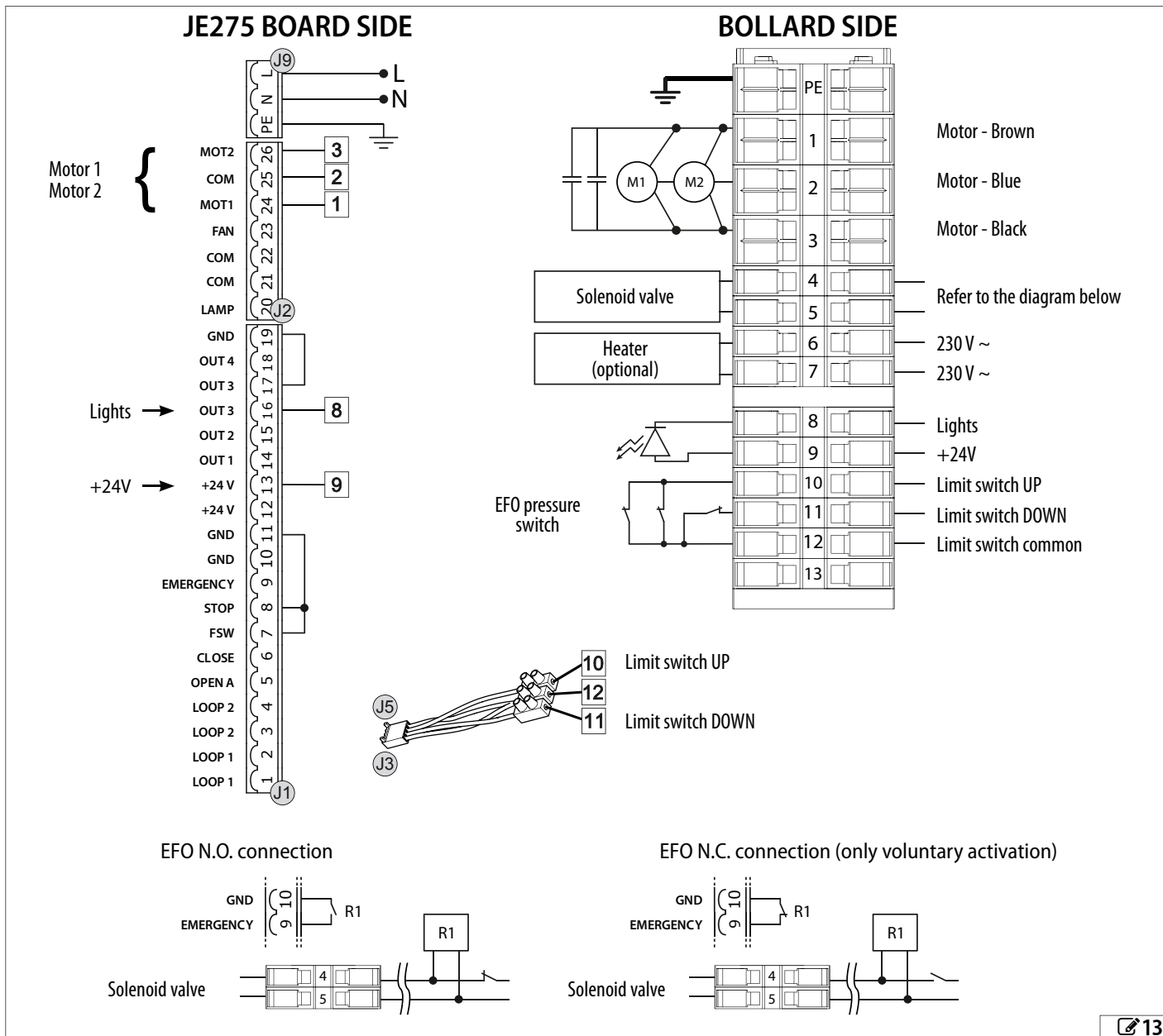

3.2 BOARD PROGRAMMING

After connecting and switching on the power to the control board as per the previous chapter, select the work pre-setting for the bollard J355HA M30-P1 by performing the following operation:

1. Access level 1 programming by holding down the F button on the control board (15). The display will show the letters dF.
2. Release the F button and with the + button, select the value 06

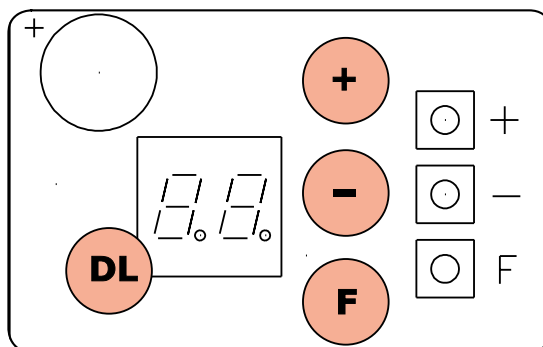

3. Press the F button and hold it down whilst simultaneously pressing the – button to exit programming screen and save the changes made.
4. Press the F button and hold it down, as well as pressing + for around 10 seconds, until the display shows □!
5. Release the buttons, then press the F button scroll until you reach the b6 parameter
6. Set the value b6 = 4
7. Press the F button and hold it down whilst simultaneously pressing the – button to exit programming screen and save the changes made.



For more information on programming the equipment, please refer to the relevant instructions.

3.3 CONNECTION OF SEVERAL BOLLARDS (MASTER/SLAVE)

Several bollards can be commanded simultaneously by connecting them together with the corresponding JE275 equipment in MASTER-SLAVE configuration. Follow the indications below for correct wiring and operation.

JE275 MASTER

1. dF = 06
2. o1 = 11
P1 = no
o2 = 12
P2 = no
3. 10s b6 = 4

JE275 SLAVE

1. dF = 06
LO = C
2. 10s b6 = 4

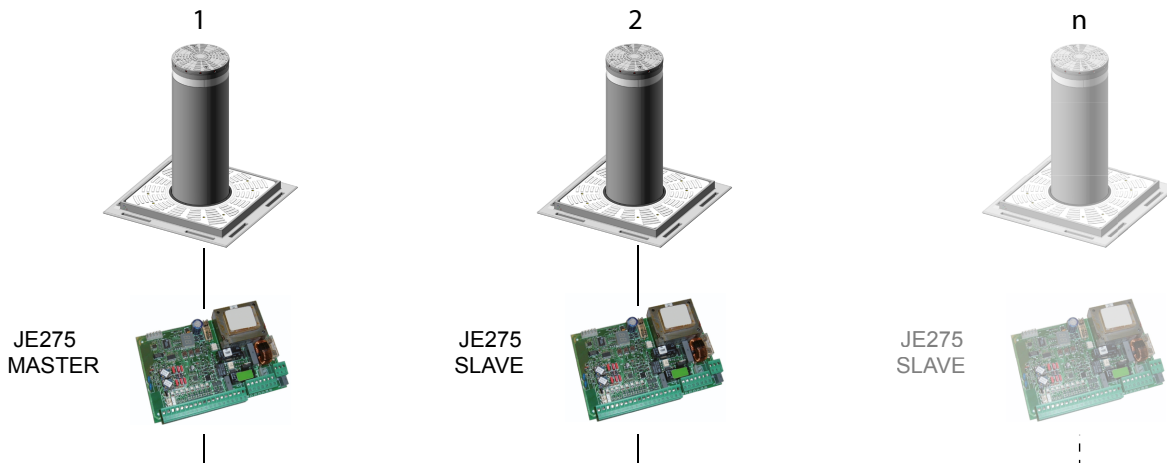
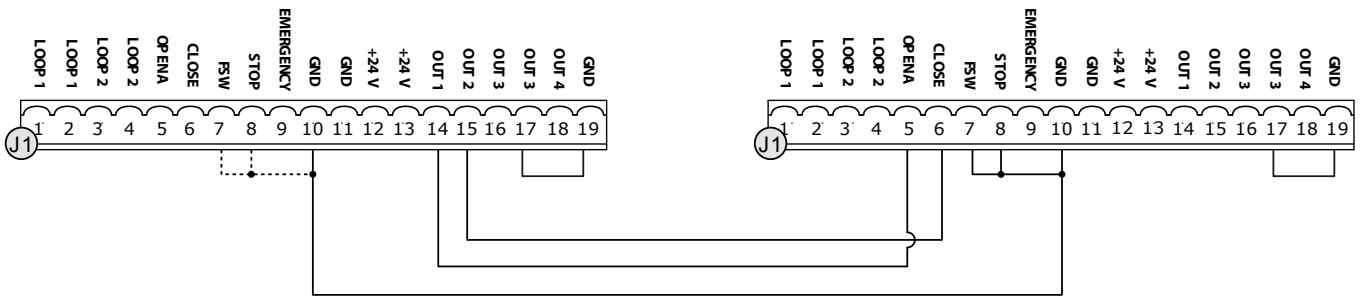

3.4 TROUBLESHOOTING

The indications below will help you locate and solve particular conditions.

CONDITION	ADVICE
The bollard does not rise, it remains down.	Make sure you have selected the default no. 6 on the JE275 board Check if the wiring of the solenoid valve was performed correctly, see par. 9 Check the electrical wiring of the motor
The bollard remains up in closed position.	Make sure nothing between the cylinder and the sliding bush prevents the bollard movement Check the electrical wiring of the motor
The LED flashing lamp does not operate	Make sure you have selected the default no. 6 on the JE275 board Check if the power connector under the head was fitted correctly.

4. PERFORMING MAINTENANCE ON THE EFO SYSTEM



The EFO system tank is always under pressure. Before carrying out any maintenance operation, to avoid potentially dangerous situations, the circuit must be discharged before any other operation.

The bollard is rapidly closed when the EFO is activated. Clear the relative area from objects and people in order to prevent dangerous situations

To discharge the EFO, activate the system by opening the contact between terminals 7 and 8 of the terminal board (EFO N.O.) or supplying voltage to the solenoid valve via the same terminals (EFO N.C.), then **slowly** unscrew the screws in figure 15, ref. ①

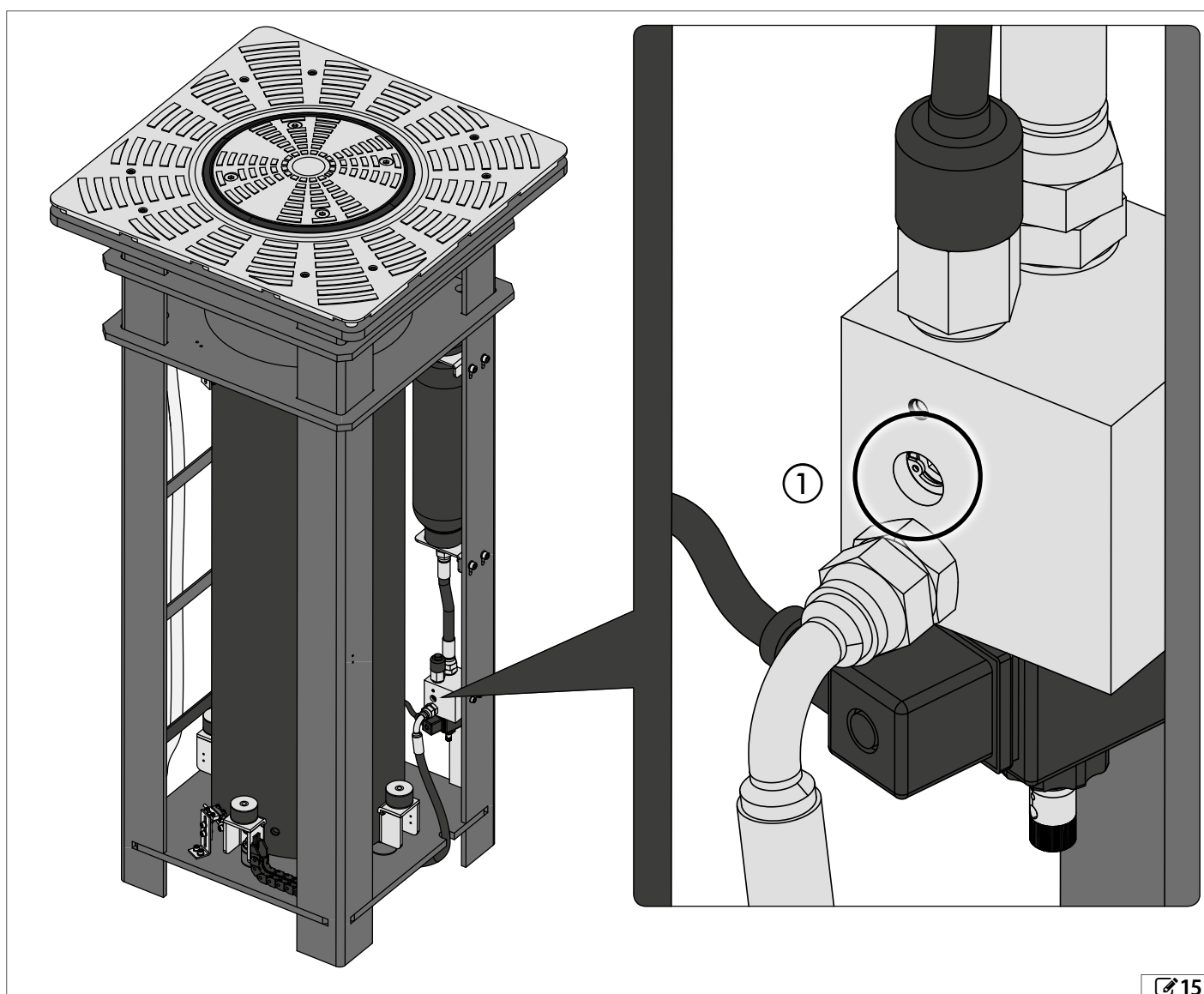

15



FAAC S.p.A. Soc. Unipersonale
Via Calari, 10 - 40069 Zola Predosa BOLOGNA - ITALY
Tel. +39 051 61724 - Fax +39 051 758518
www.faac.it - www.faacgroup.com