

# 770N

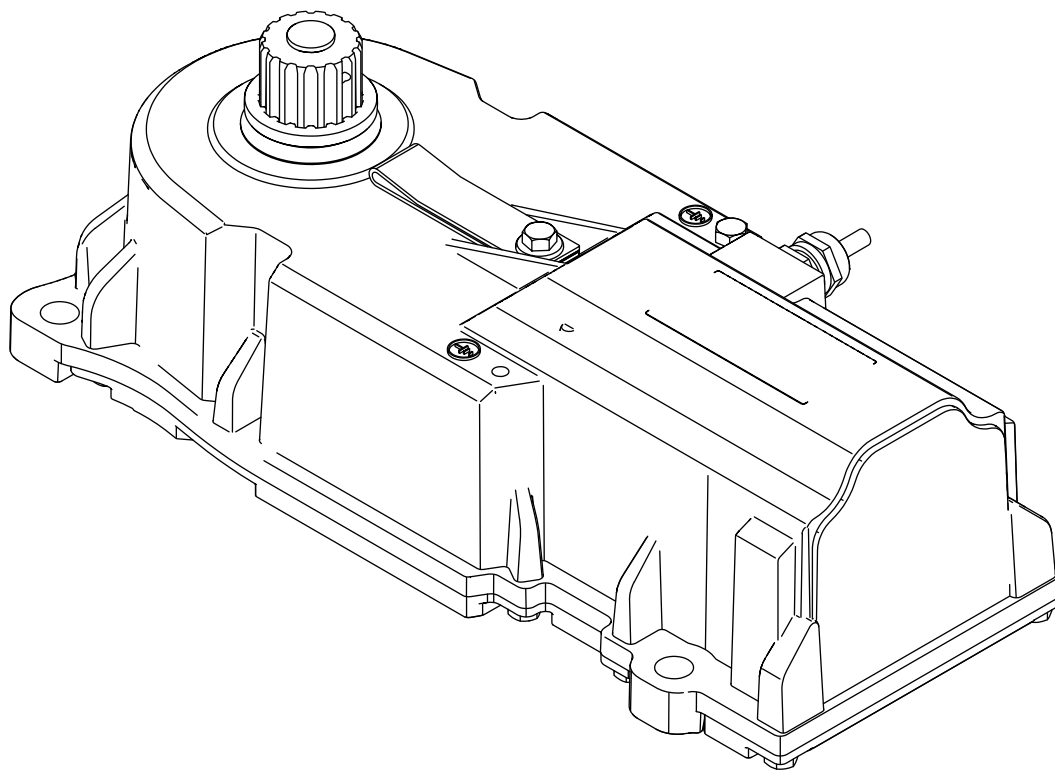

**FAAC**

Translation of the original instructions

1. IMPORTANT WARNINGS FOR THE INSTALLER.....	3
2. DESCRIPTION OF THE COMPONENTS .....	3
3. TECHNICAL SPECIFICATIONS .....	3
4. INSTALLATION.....	3
4.1 ELECTRICAL PREPARATIONS (STANDARD SYSTEM) .....	3
4.2 PRELIMINARY CHECKS .....	3
4.3 INSTALLING THE SUPPORTING BOX .....	3
4.4 INSTALLING THE LEAF.....	4
4.5 INSTALLING THE GEARMOTOR .....	4
4.6 ELECTRICAL CONNECTIONS .....	4
5. START-UP.....	4
6. MANUAL OPERATION.....	4
7. RESTORING NORMAL OPERATION .....	4
8. AVAILABLE ACCESSORIES.....	4
9. MAINTENANCE.....	4
10. REPAIRS.....	4
11. SPECIAL APPLICATIONS.....	4

**EU DECLARATION OF CONFORMITY**

The Manufacturer

**Company name:** FAAC S.p.A. Soc. Unipersonale

**Address:** Via Calari, 10 - 40069 Zola Predosa BOLOGNA - ITALIA

hereby declares under his sole responsibility that the following product:

**Description:** Underground actuator for swing gates

**Model:** 770N

Complies with the following relevant Union harmonization legislations:

2014/30/EU  
2011/65/EU

Furthermore, the following harmonised standards have been applied:

EN 61000-6-2:2005  
EN 61000-6-3:2007 + A1:2011

Bologna, 19-03-2018      CEO  
A. Marcellan 

**DECLARATION OF INCORPORATION FOR PARTLY COMPLETED MACHINERY**

(2006/42/EC ANNEX II P.1, B)

Manufacturer and person authorised to draft the applicable technical documentation

**Company name:** FAAC S.p.A. Soc. Unipersonale

**Address:** Via Calari, 10 - 40069 Zola Predosa BOLOGNA - ITALIA

Hereby declares that the partly completed machinery:

**Description:** Underground actuator for swing gates

**Model:** 770N

the following essential requirements of the Machinery Directive 2006/42/EC (including all applicable amendments) have been applied and fulfilled:

1.1.2, 1.1.3, 1.1.5, 1.1.6, 1.3.1, 1.3.2, 1.3.4, 1.4.1, 1.4.2.1, 1.5.1, 1.5.5, 1.5.6, 1.5.8, 1.6.1, 1.6.4, 1.7.1, 1.7.2, 1.7.3, 1.7.4.2, 1.7.4.3

and that the relevant technical documentation has been compiled in compliance with part B of Annex VII.

Furthermore, the following harmonised standards have been applied:

EN12100:2010  
EN13849-1:2015  
EN13849-2:2012

Other applied standards:

EN 12453:2017

Undertakes to transmit by mail or by e-mail, in response to a reasoned request by the national authorities, relevant information on the partly completed machinery. It is also declared that the partly completed machinery identified above may not be commissioned until the final machine - into which it will be incorporated - has been declared compliant with the provisions of the above mentioned Machine Directive 2006/42/EC.

Bologna, 19-03-2018      CEO  
A. Marcellan 

Notes on reading the instruction

Read this installation manual to the full before you begin installing the product.

The symbol  indicates notes that are important for the safety of persons and for the good condition of the automated system.

The symbol  draws your attention to the notes on the characteristics and operation of the product.

Thank you for choosing our product. FAAC S.p.A. is sure you will get the performances you expect to satisfy your requirements. All our products are the result of a many years' experience in the field of the automated systems.

 In the middle of the manual you will find a detachable booklet containing all the images for the installation.

### 1. IMPORTANT WARNINGS FOR THE INSTALLER

- Carefully read the whole manual before beginning to install the operator.
- Store the manual for future reference.
- The correct operation and the declared technical specifications are only valid if the instructions given in this manual are strictly observed and only FAAC S.p.A. accessories as well as safety device are used.
- Due to the lack of a mechanical clutch, it is necessary to use a control unit with an adjustable electronic clutch.
- The automated system was designed and built to control vehicle access. Avoid any other use.
- The operator cannot be used to move safety exits or gates installed on emergency routes (escape routes).
- Do not transit when the gate is moving.
- If the leaf you wish to motorise features a built-in door for pedestrian passage, the door must be equipped with a safety switch in order to disable operation of the gate when the door is open.
- Anything not expressly specified in this manual is not permitted.

### 2. DESCRIPTION OF THE COMPONENTS

With reference to the fig.1

Pos.	Description
①	Supporting box
②	Operator
③	Gate support frame
④	110° manoeuvre lever system
⑤	140° manoeuvre lever system (optional)
⑥	Release device
⑦	Cover
⑧	Draining hole
⑨	Cable routing holes
⑩	Lubrication hole

### 3. TECHNICAL SPECIFICATIONS

Model 770N	230V	24V
System power supply	230V~ 50Hz	
Motor power supply	230V~ 50Hz	24V==
Thermoprotection (°C)	140	/
Capacitor (µF)	12.5	/
Absorbed power (W)	380	70
Max. torque (Nm)	330	330
Nominal torque (Nm)	220	200
Opening angle (°)	110 (140 and 180 with kit)	
Angular speed (°/sec.)	6	6
Max leaf length (m)	3.5 (110°) - 3 (180°) - 2.5 (140°)	
Max leaf weight	See fig.2	
Usage frequency and type	S3 30%	100%
Protection class	IP 67	
Noise level dB(A)	<70	
Operating temperature (°C)	-20 to +55	
Weight (Kg)	Operator (kg)	12,5
	Supporting box (kg)	15.3
Operator dimensions (mm)	362 x 153 H 127	
Supporting box dimensions (mm)	See fig.3	

① Values obtained from laboratory testing.

### 4. INSTALLATION

#### Max usage curve

The curve (fig.4) makes it possible to identify the maximum operation time (T) depending on the frequency of use (F) for 230V~ motors. To guarantee good operation it is necessary to remain within the work range below the curve.

 The curve is obtained at a temperature of 20°C. Exposure to direct sunlight can determine a drop in usage frequency up to 20%.

#### HOW TO CALCULATE THE USAGE FREQUENCY

$$\%F = \frac{T_a + T_c}{T_a + T_c + T_p + T_i} \times 100$$

Ta = opening time

Tc = closing time

Tp = pause time

Ti = interval between one complete cycle and the next

#### 4.1 ELECTRICAL PREPARATIONS (STANDARD SYSTEM)

With reference to the fig.5:

Pos.	Description	Cable Nr. and Diam.	
①	Gearmotor	230 V~	4x1.5mm <sup>2</sup>
		24 V==	2 x see table
②	Control unit (system power supply)	3x1.5mm <sup>2</sup>	
③	TX Photocells	2x0.5mm <sup>2</sup>	
④	RX Photocells	4x0.5mm <sup>2</sup>	
		2x0.5mm <sup>2</sup> (BUS)	
⑤	Key switch	2x0.5mm <sup>2</sup>	
⑥	Flashing lamp	2x1.5mm <sup>2</sup>	

 For cable installation, use adequate rigid and/or flexible tubes.

 Separate the 230 V~ power cables from the low-voltage ones.

#### 24V MOTOR CABLE DIAMETER

Conductor diameter	Operator - Board distance		
	Up to 15 m	From 15 m to 25 m	From 25 m to 35m
2.5 mm <sup>2</sup>	4 mm <sup>2</sup>	6 mm <sup>2</sup>	

#### 4.2 PRELIMINARY CHECKS

1. The mechanical elements used for construction must comply with EN 12604 and EN 12605 Standards.
2. The leaf structure must be suitable for automation.
3. Minimum distance between the lower edge of the leaf and the floor, as shown in fig.6.
4. Presence of mechanical leaf limit stops.
5. Check for the presence of only the upper hinge.

 **The condition of the structure directly affects the reliability and safety of the automated system.**

 Before installing the automated system, carry out any necessary smith work on the gate.

#### 4.3 INSTALLING THE SUPPORTING BOX

1. Choose the orientation of the box according to the dimensions shown in fig.7 and 8.
  2. Dig a hole to position the supporting box (fig.9).
-  Modify the dimensions of the hole based on the type of ground (the dimensions in fig.9 refer to the minimum dimensions of the hole).
3. Position the box as shown in fig.10.
  4. Place a rigid tube or a flexible sheath for passage of the power supply cables, fig.11 ref.①.
  5. Place a tube for draining rain water, fig.11 ref.②.
  6. Ensure that the box is walled-in flat.

#### 4.4 INSTALLING THE LEAF

1. Create a leaf containment frame as shown in fig.12.
2. Determine the position of the leaf based on the rotation axis.

3. Close the containment frame as shown in fig.13 and 14.
4. Weld the leaf containment frame to the leaf support frame, fig.15.
5. Assemble all parts as shown in fig.16.
6. Carefully grease the rotation pin and the ball.

 **Do not grease the release device.**

7. Position the leaf and secure the upper hinge.
8. Manually move the leaf to ensure correct positioning.
9. Secure the leaf to the containment frame using a through screw, fig.17.

 **Do not weld the leaf to the containment frame.**

#### 4.5 INSTALLING THE GEARMOTOR

1. Place the gearmotor in the box as shown in fig.18, using the provided handle ref.① for handling.

 *To correctly position the gearmotor, refer to figure 19. In any case, the gearmotor transmission shaft must be on the side opposite gate opening.*

2. Secure the gearmotor using the provided nuts and washers.
3. Install the transmission levers as shown in fig.20.

 *Grease the lever pins.*

 *The gears of the 180° plate (optional) do not require greasing.*

4. Fit any optional accessories, see the paragraph titled "Accessories".

#### 4.6 ELECTRICAL CONNECTIONS

1. Insert the motor power cable in the previously laid tube.
2. Make all the connections with the electrical cabinet, following the instructions provided with the cabinet itself.

 *If the motor cable needs to be extended, provide for shunt boxes with a protection class IP 67 or greater, inside the supporting box.*

 *Use a cable suitable for outdoor laying, having the proper diameter, as described in the paragraph "Electrical preparations".*

3. Insert the plug, fig.21 ref.②.
4. Close the cover of the supporting box, fig.21 ref.①.
5. Screw in the cover using the provided screws.

#### 5. START-UP

1. Programme the control equipment according to need.
2. Ensure that the automated system is operating correctly.
3. Check that the safety devices operate correctly.
4. Fill in the maintenance report, contained in the middle of this manual, and give it to the end user.
5. Properly train the end user as to the correct operation of the automated system.
6. Give the end user the "User's Guide" that is contained in the middle of the manual.

#### 6. MANUAL OPERATION

1. Use the differential switch located upstream from the system to cut off power.
2. Open the lock covering the plug, fig.22 ref.①.
3. Insert the key and turn it until it stops, fig.22 ref.②.
4. Open the release lever, fig.22 ref.③.
5. Manually move the leaf, fig.22 ref.④.
6. Place the release lever back in position.

#### 7. RESTORING NORMAL OPERATION

1. Use the differential switch located upstream from the system to cut off power.
2. Manually move the leaf until the release device engages, fig.23 ref.①.
3. Place the release lever in rest position, fig.23 ref.②.
4. Turn the key until it stops, fig.23 ref.③.
5. Close the protective plug, fig.23 ref.④.
6. Ensure that the leaf cannot be moved manually.
7. Power on the system and perform a few cycles to ensure that the automated system is operating correctly.

#### 8. AVAILABLE ACCESSORIES

##### Mechanical limit stops

The mechanical limit stops have been designed to replace the mechanical beats of the leaf (fig.24).

To install the stops, refer to the related instructions.

 *The mechanical limit stops cannot be used with the 180° opening*

*kit.*

##### Kit 180°

This kit lets you obtain a leaf rotation of up to 180° (fig.25).

 *If this kit is used, you cannot use the mechanical limit stops inside the box.*

To install the kit, refer to the related instructions.

##### Kit 140°

This kit lets you obtain a leaf rotation of up to 140° (fig.26)

 *Con l'utilizzo degli arresti meccanici all'interno della cassetta di fondazione la rotazione dell'anta è limitata a ~120°.*

To install the kit, refer to the related instructions.

##### Encoder

The encoder is used to detect possible obstacles that prevent normal operation of the automated system (fig.27 example of installation combined with kit 180°).

To install the encoder, refer to the related instructions.

##### Magnetic limit switch

Using this kit - fig.28 - you can determine the leaf stopping point or the start of the decelerated segment, depending on the characteristics of the control board used.

 *Use of the magnetic limit switch requires the use of a control unit that supports limit switches.*

 **The magnetic limit switch cannot be installed with the 180° kit and encoder.**

To install the kit, refer to the related instructions.

#### 9. MAINTENANCE

Inspect the system every **six months**, as provided for in current safety regulations.

The "User's Guide" contains a servicing report form.

#### 10. REPAIRS

Do not make any attempts at repairs and contact only qualified FAAC S.p.A. personnel and service centres.

#### 11. SPECIAL APPLICATIONS

No special applications have been provided for, any use not described in this manual is strictly forbidden.

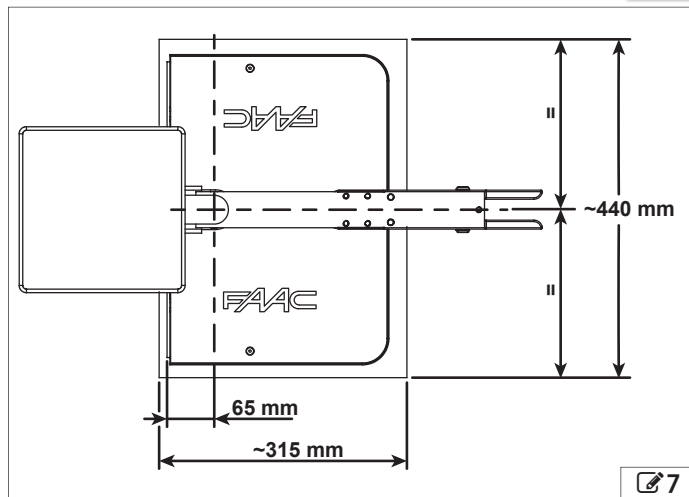
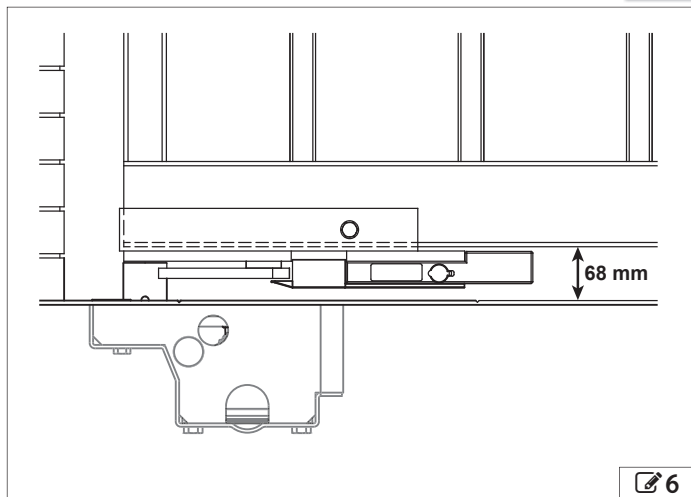
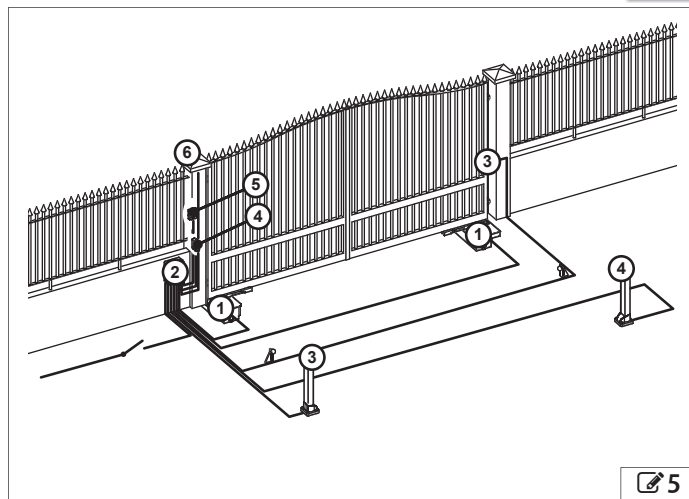
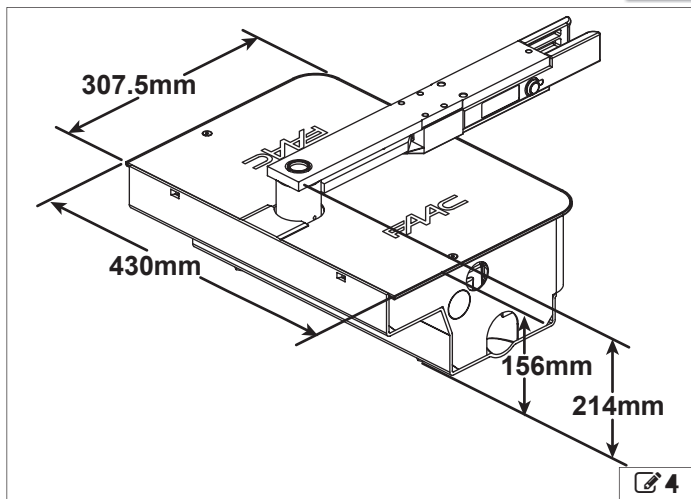
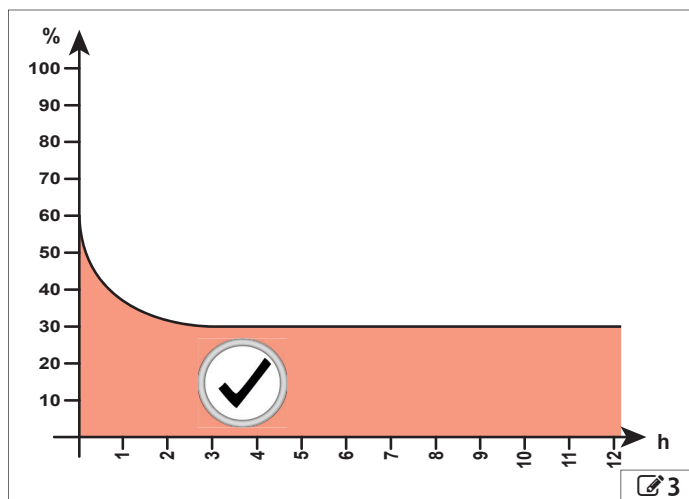
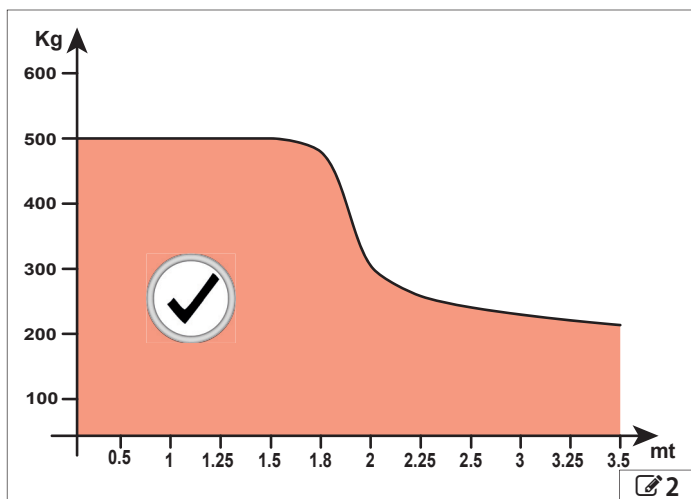
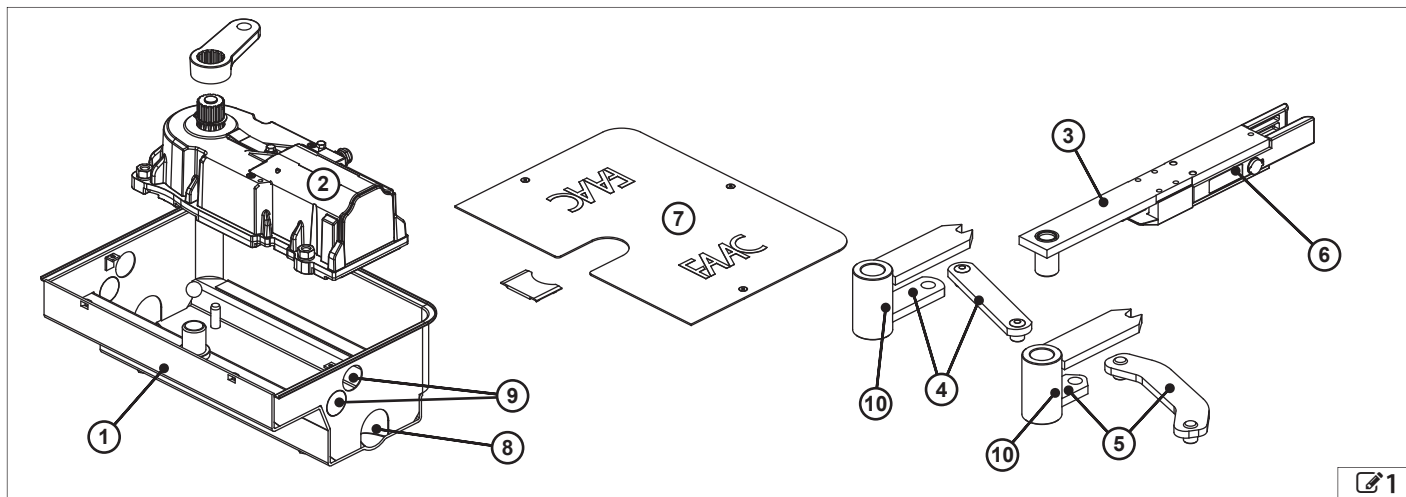

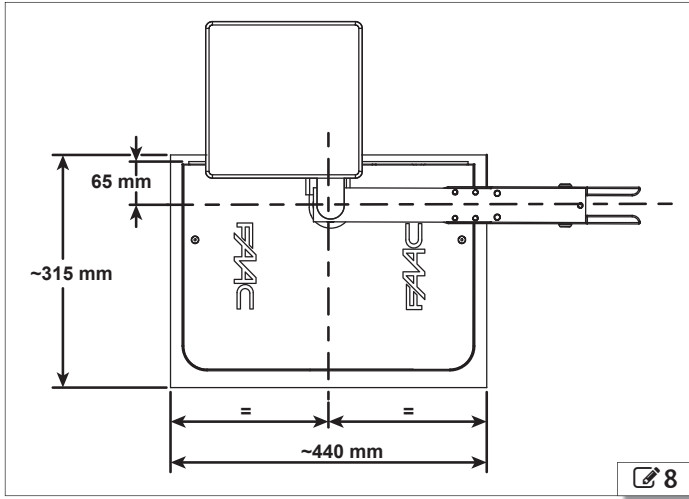

8

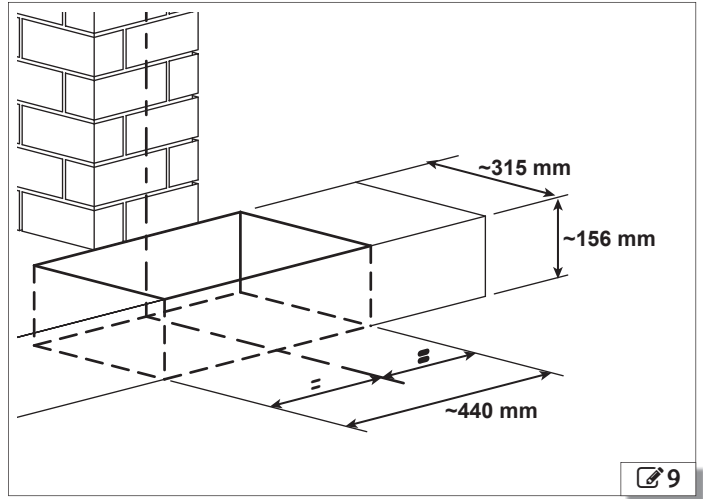

9

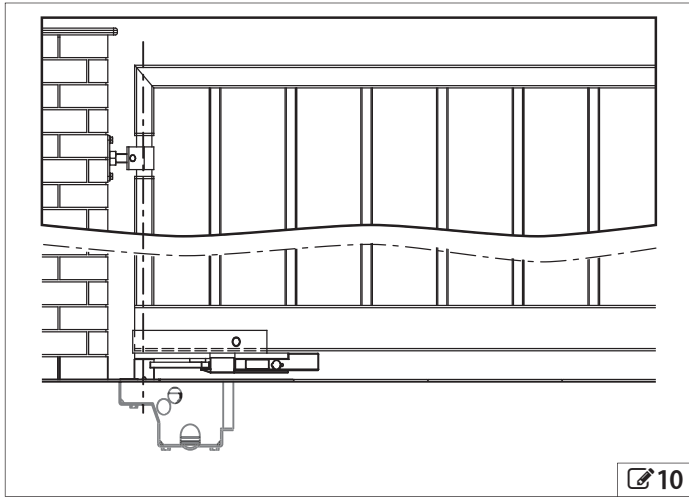

10

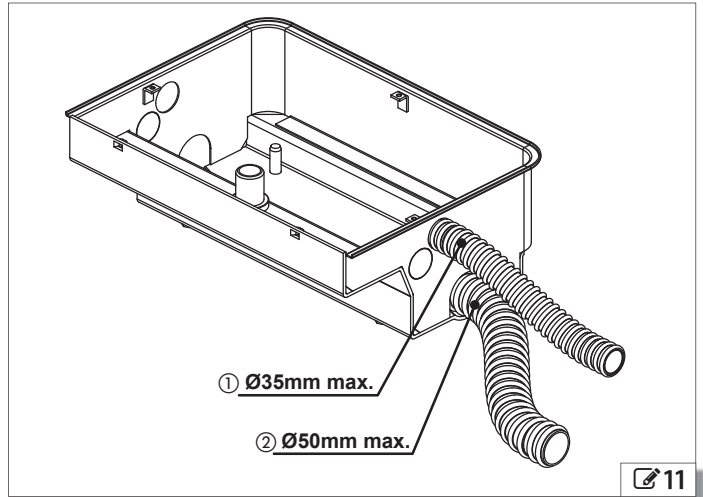

11

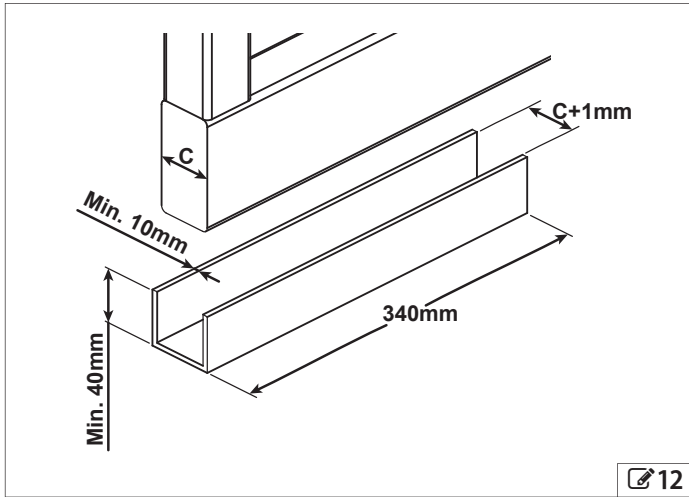

12

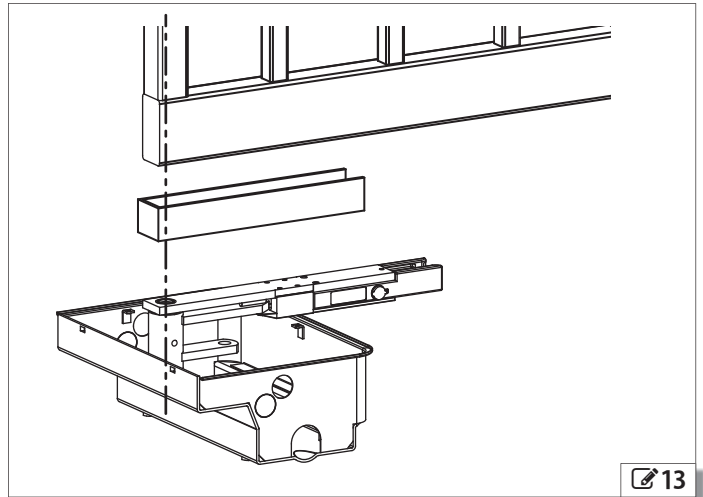

13

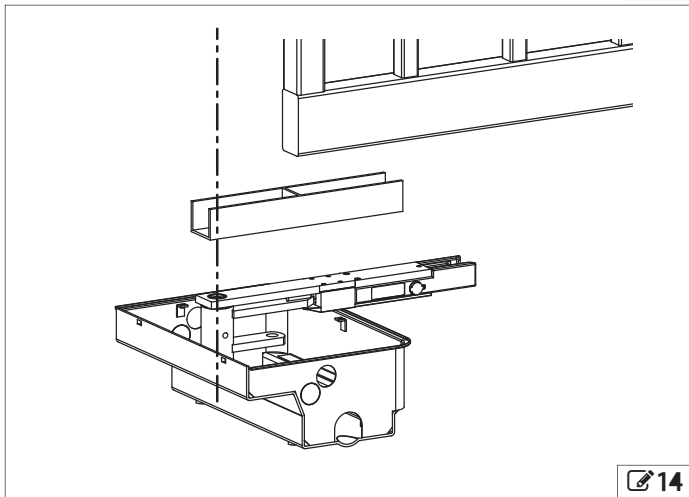

14

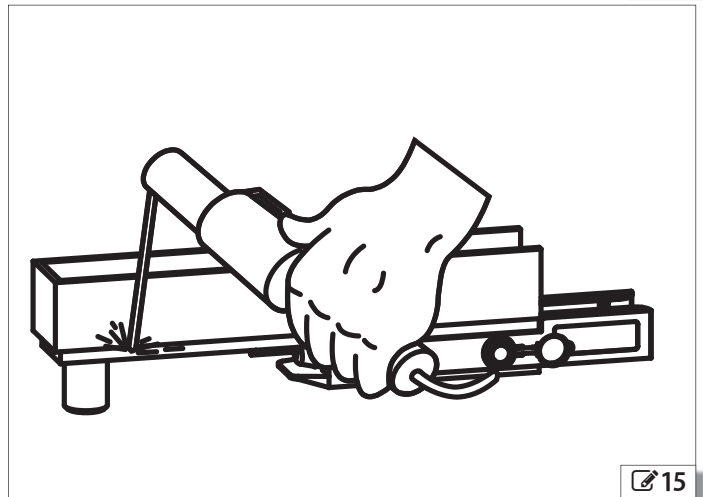

15

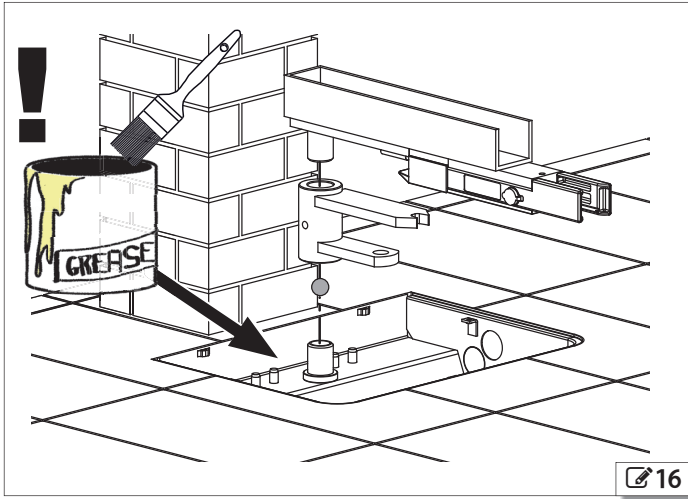

16

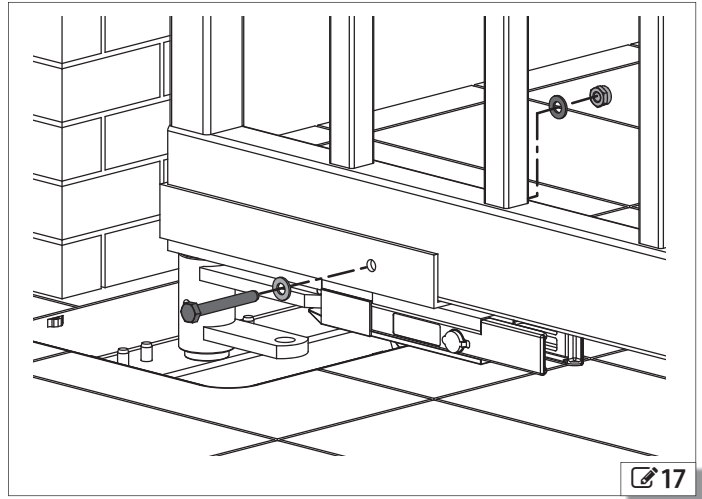

17

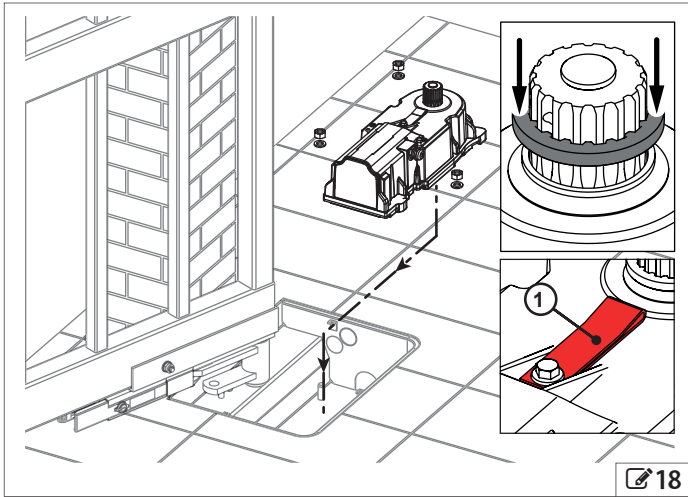

18

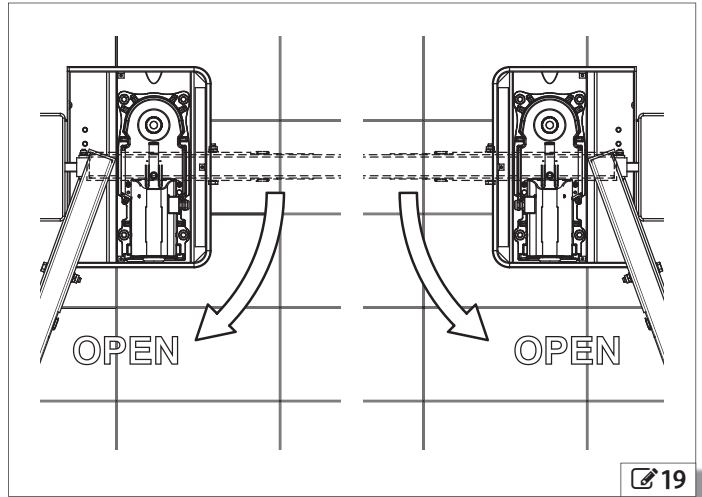

19

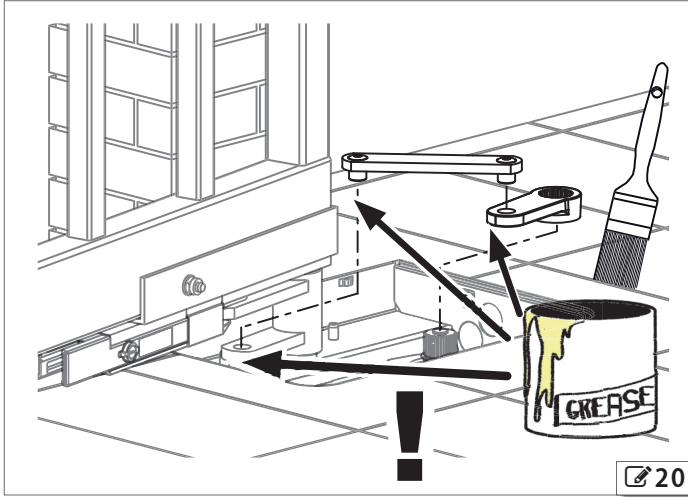

20

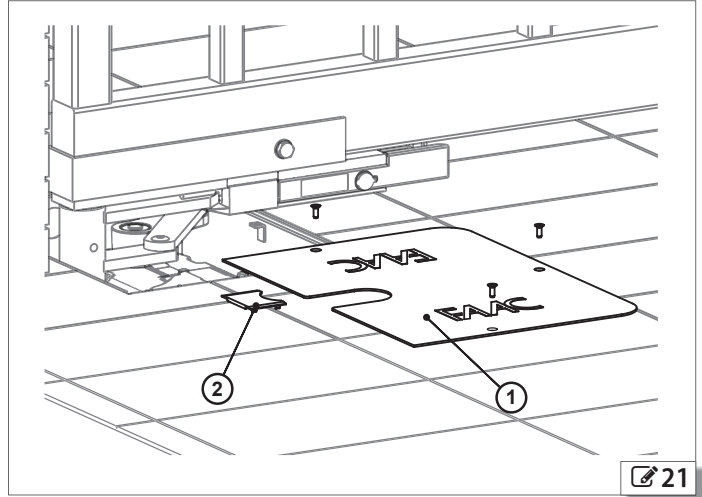

21

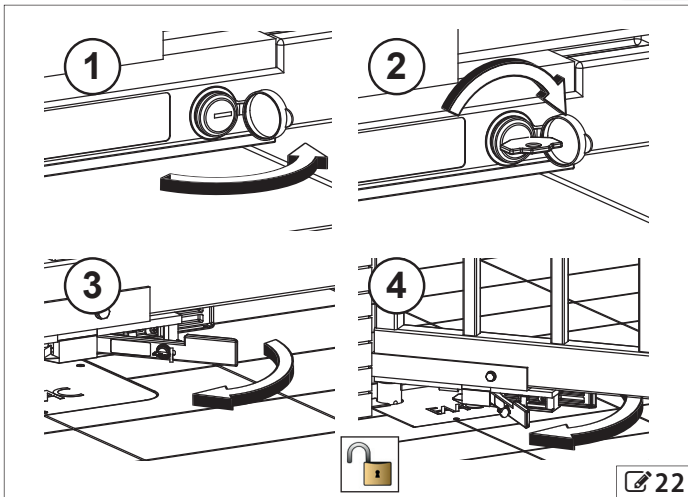

22

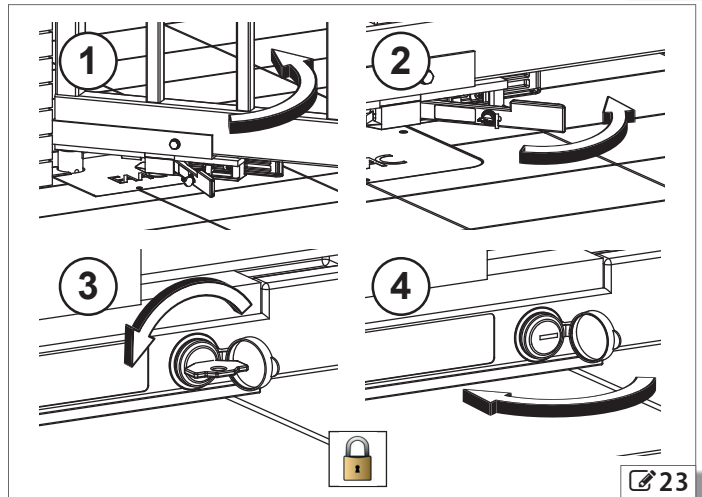

23

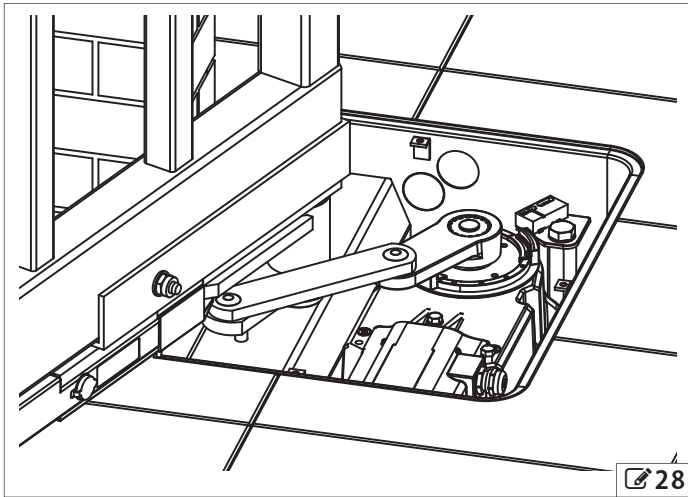
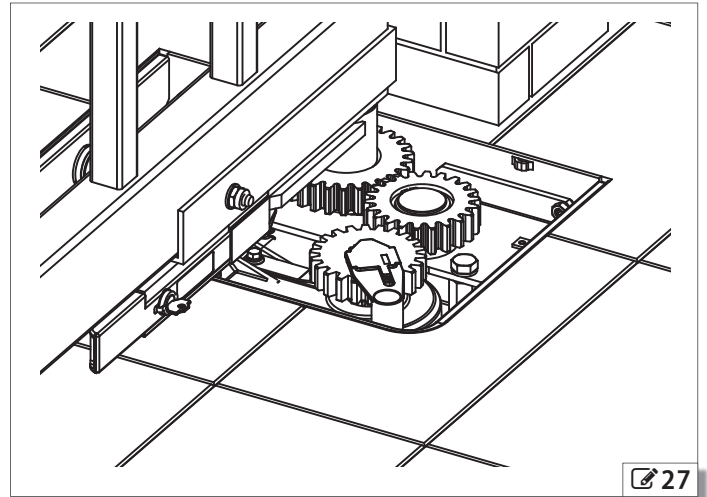
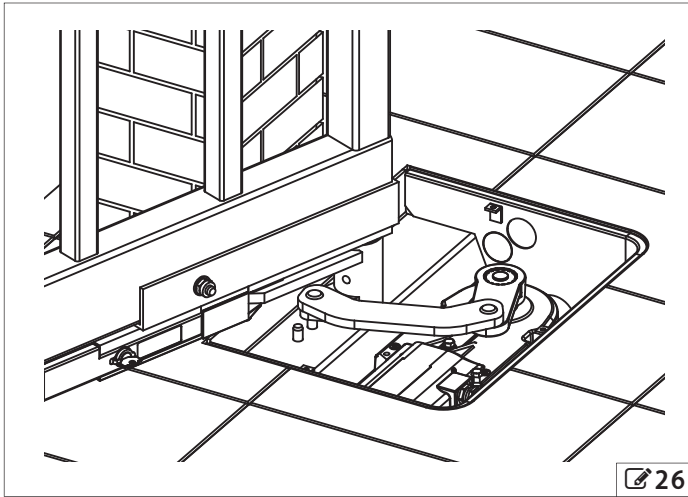
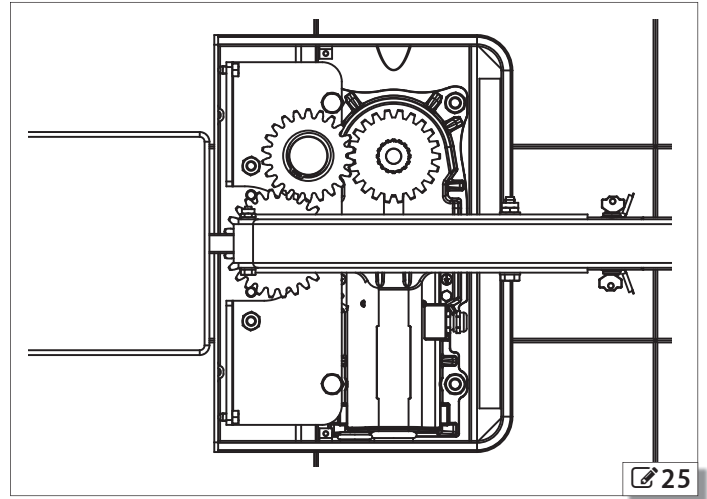
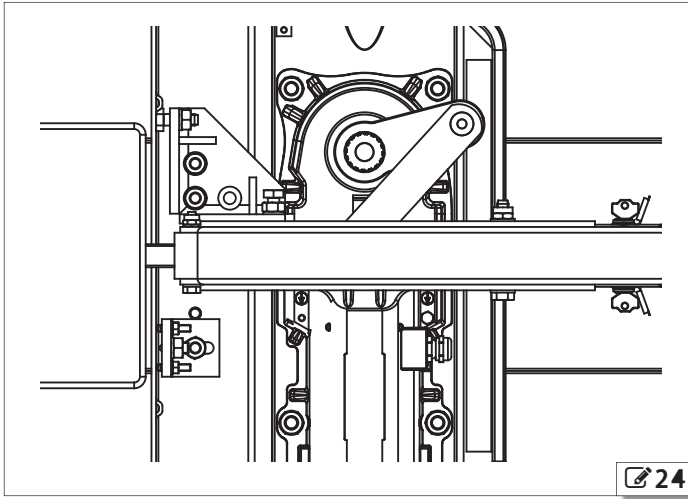



# 770 N

**EN**  
**USER'S GUIDE**

The FAAC logo is positioned at the bottom left of the page. It features the letters 'FAAC' in a bold, black, sans-serif font. The letter 'F' is stylized with a diagonal slash through its middle bar. The 'A' is a simple, blocky letter. The 'C' is a simple, blocky letter. The 'A' and 'C' are connected to the 'F' by a thin horizontal line.

**FAAC**

Thank you for choosing our product. FAAC S.p.A. is sure you will get the performances you expect to satisfy your requirements. All our products are the result of a many years' experience in the field of the automated systems.

**⚠ Store this manual for future reference.**

## GENERAL SAFETY REGULATIONS

1. Do not transit when the leaves is moving.
2. Do not stand within the range of the leaf movement.
3. Keep radio-controls, or any other pulse generators, well away from children.
4. Do not allow children to play with the automated system.
5. The automated system must not be used by children, persons with limited physical and mental capacities or persons lacking experience or the necessary training.
6. Do not willingly obstruct leaf movement.
7. Prevent any branches or shrubs from interfering with leaf movement.
8. Keep indicator-lights efficient and easy to see.
9. Do not attempt to activate the gate by hand unless you have released it.
10. In the event of malfunctions, release the gate to allow access and wait for qualified technical personnel to do the necessary work.
11. Do not in any way modify the components of the automated system.
12. Request maintenance service every six months, as provided for in current safety regulations.

## OPERATION DESCRIPTION

The **770 N** automated system consists of an irreversible electromagnetic gearmotor housed in a corresponding supporting box. The gearmotor is invisibly installed in the ground and therefore does not affect the aesthetics of the gate.

When in rest position, the gate leaves are closed.

When a pulse is sent, the unit sets the motor in motion, which will begin to open the leaves until opening is complete.

Once the opening phase is completed, if an automatic operation logic has been selected, the unit will begin the pause time count. Once the set pause time has expired, the unit commands the gate to close.

If instead a semi-automatic operating logic has been selected, once the opening phase is completed, a pulse must be sent to close the leaves.

For details on operating the gate and all the installed accessories, please speak with the installation technician.

## MANUAL OPERATION

1. Use the differential switch located upstream from the system to cut off power.
2. Open the lock covering plug, ref. 1.
3. Insert the key and turn it until it stops, ref. 2.
4. Open the release lever, ref. 3.
5. Manually move the leaf, ref. 4.
6. Place the release lever back in position.

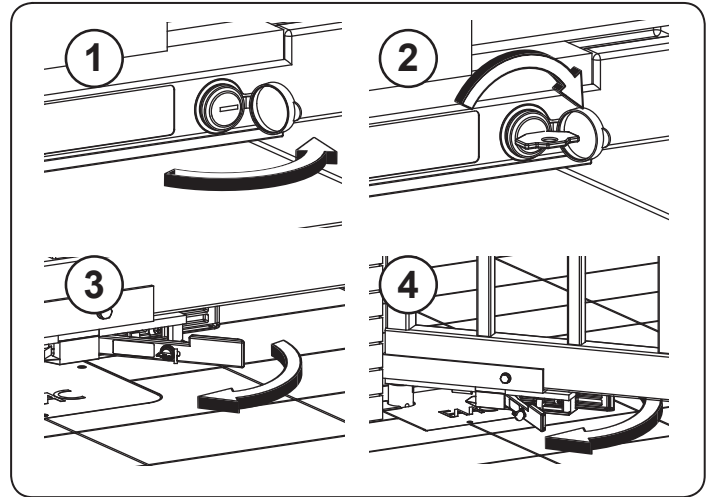

## RESTORING NORMAL OPERATION MODE

1. Use the differential switch located upstream from the system to cut off power.  
Manually move the leaf until the release device engages, ref. ①.
2. Place the release lever in rest position, ref. ②.
3. Turn the key until it stops, ref. ③.
4. Close the protective plug, ref. ④.
5. Ensure that the leaf cannot be moved manually.
6. Power on the system and perform a few cycles to ensure that the automated system is operating correctly.

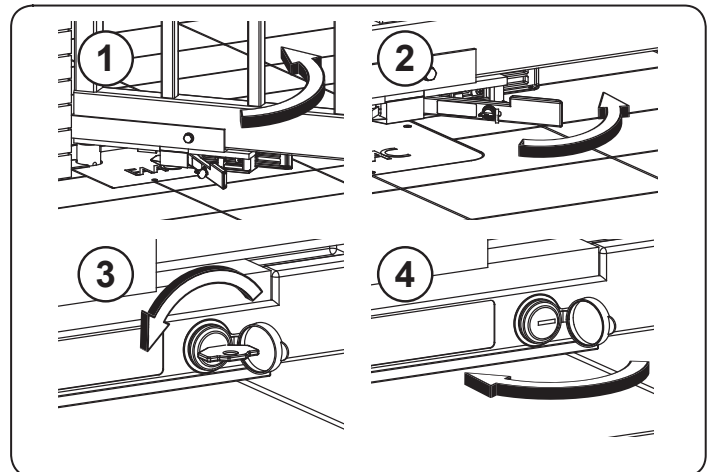

## MAINTENANCE

Have the system inspected every **six months**, as provided for in current safety regulations.

This booklet contains a form for reporting servicing. Ensure that it is filled in all its parts.

## REPAIRS

Do not make any attempts at repairs and contact only qualified FAAC S.p.A. personnel and service centres.

## SPECIAL APPLICATIONS

No special applications are provided for.

# MAINTENANCE REGISTER

Installation technician \_\_\_\_\_  
 Customer \_\_\_\_\_  
 Type of system \_\_\_\_\_  
 Serial number \_\_\_\_\_  
 Installation date \_\_\_\_ / \_\_\_\_ / \_\_\_\_ Activation \_\_\_\_\_  
 System configuration \_\_\_\_\_

PART	MODEL	SERIAL NUMBER
Actuator	FAAC 770N	
Safety device 1		
Safety device 2		
Pair of photocells 1		
Pair of photocells 2		
Control device 1		
Control device 2		
Remote control		
Flashing lamp		
Other device		

**Indication of residual risks and of foreseeable improper use**

Date	Description of job	Signatures
	_____	<b>Technician</b>
	_____	<b>Customer</b>
	_____	<b>Technician</b>
	_____	<b>Customer</b>
	_____	<b>Technician</b>
	_____	<b>Customer</b>
	_____	<b>Technician</b>
	_____	<b>Customer</b>
	_____	<b>Technician</b>
	_____	<b>Customer</b>
	_____	<b>Technician</b>
	_____	<b>Customer</b>



FAAC S.p.A. Soc. Unipersonale  
Via Calari, 10 - 40069 Zola Predosa BOLOGNA - ITALY  
Tel. +39 051 61724 - Fax +39 051 758518  
[www.faac.it](http://www.faac.it) - [www.faacgroup.com](http://www.faacgroup.com)