

A100 Compact

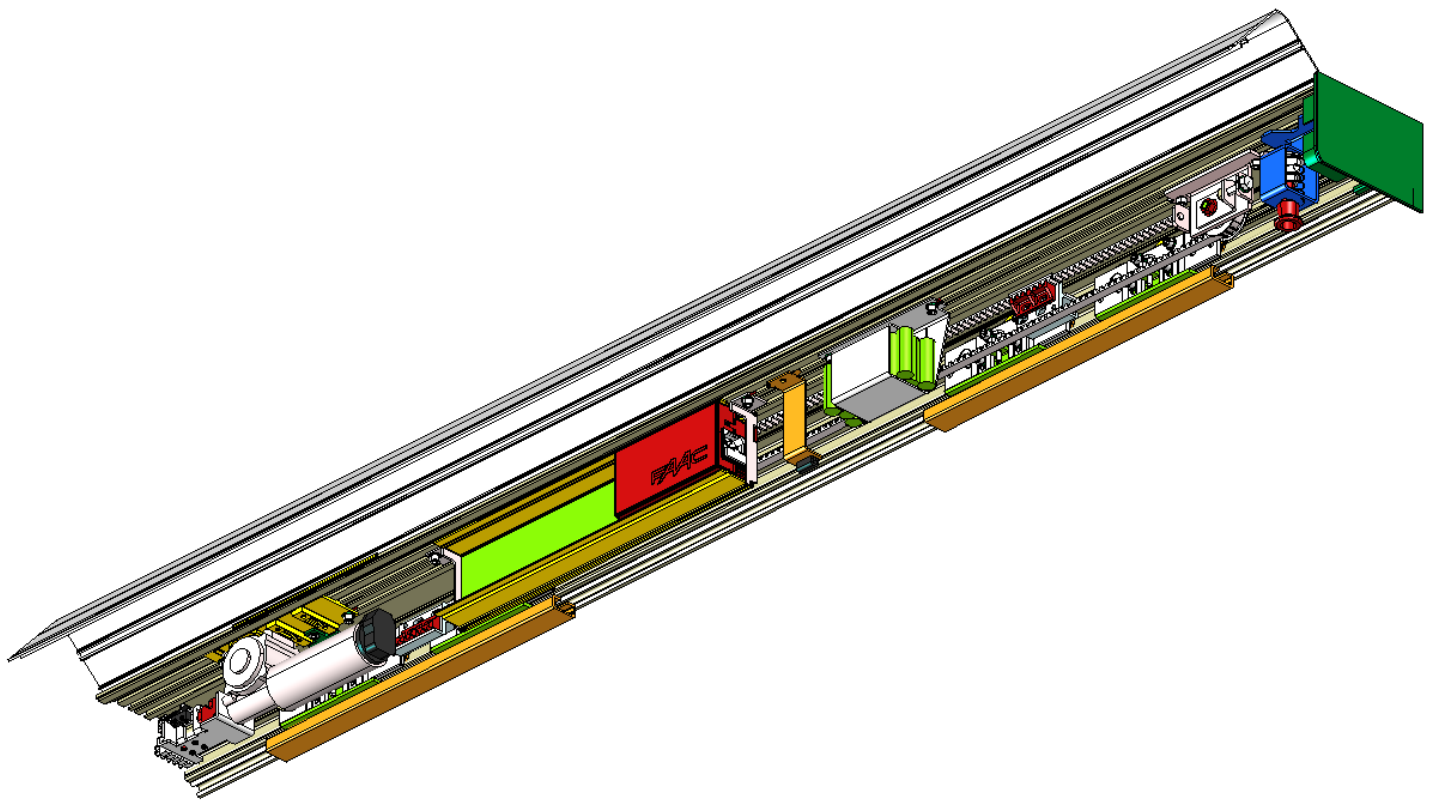

EN16005

FAAC

EC DECLARATION OF INCORPORATION OF PARTLY COMPLETED MACHINE

The undersigned, representing the following manufacturer :

Manufacturer : FAAC S.p.A.

Address : Via Calari ,10 - 40069 Zola Predosa BOLOGNA - ITALIA

herewith declares that to the partly completed machinery :

Description : Linear sliding door to 1 or 2 leaf

Model : A100 Compact

the essential requirements of the following EC directive (including all applicable amendments)

- 2006/42/EC Machinery Directive

have been applied and fulfilled, and that the relevant technical documentation is compiled in accordance with part B of Annex VII of the above mentioned Machinery Directive.

The above identified partly completed machinery is also in compliance with the all the relevant provisions of the following EC directive (including all applicable amendments)

- 2004/108/EC EMC Directive

The following harmonized standards have been applied:

- o EN 16005:2012
- o EN 61000-6-2:2005
- o EN 61000-6-3:2007

The above identified partly completed machinery must not be put into service until the final machinery into which it is to be incorporated has been declared in conformity with the provisions of the above mentioned Machinery Directive 2006/42/EC.

Bologna, 23-07-2013

Managing Director
A. Marcellan



AUTOMATIC DOOR A100 COMPACT

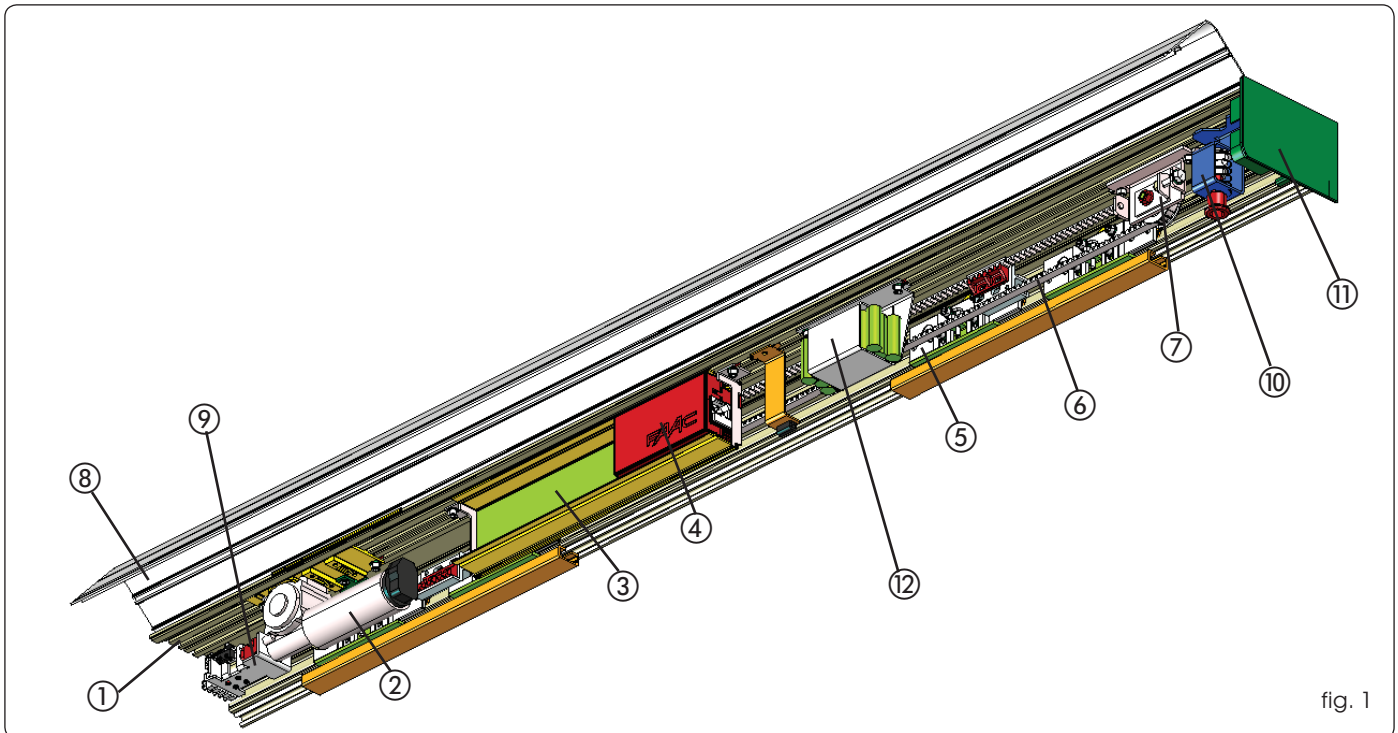

fig. 1

1 DESCRIPTION

The FAAC series A100 COMPACT systems automatically activate, manage and control the operation of single-leaf or two-leaf sliding doors.

The FAAC series A100 COMPACT automated systems are supplied completely assembled, wired and tested in the configuration requested by the customer, using the appropriate order form, or in kits to be assembled by the installation technician.

An automation cross beam (fig.1) consists of the following parts:

Support profile (fig. 1 ref. ①)

This is the profile used when the cross beam can be completely secured to a load bearing structure.

Motor unit (fig. 1 ref. ②)

The DC motor has an encoder and a leaf locking system (accessory).

Control unit (fig. 1 ref. ③)

When powered, the control unit with microprocessor, initialises the door's operational parameters.

Power feed unit (fig. 1 ref. ④)

The power feed unit, directly connected to the control unit, supplies the voltage values required to correctly power the automated system.

Leaf support carriages (fig.1 ref. ⑤)

The carriages have two wheels with ball bearings, one counter thrust wheel in the top part, and a screw based system for adjusting the height of the leaves.

Drive belt (fig. 1 ref. ⑥)

Transmission pulley unit (fig. 1 ref. ⑦)

1.1 ACCESSORIES SUPPLIED WITH THE CROSS BEAM

These parts are assembled on the cross beam.

Closing housings (fig. 1 ref. ⑧)

This is the aluminium profile enabling closure of the automated system. The side panels (fig.1 ref. ⑪) completely close the system.

Motor lock unit (fig. 1 ref. ⑨)

The motor lock unit guarantees mechanical locking of the door while the leaves are closed. The motor lock unit can be used for single and double leaves.

The motor lock unit is supplied with the internal release device (Fig.1 ref. ⑩) used for emergency opening if needed. It is also designed for installation of the external release (optional) if required. The motor lock unit acts directly on the motor, locking it mechanically.

Supervision of motor lock

It controls if the motor lock unit is operating correctly and verifies if the door is actually closed. If necessary, the system is designed for remotely activating an indicator light or buzzer/siren.

Emergency battery (fig. 1 ref. ⑫)

In the event of a mains power cut, the battery kit enables the automated system to operate until its charge is exhausted. The battery condition test is performed continuously by the control unit.

1.2 DOOR FRAME ACCESSORIES

To facilitate the door profile to adapt to the carriages and to enable correct finish of the installation, FAAC offers the following series of articles:

Pair of sliding blocks (fig. 12-13 ref. ①)

Supplied as a pair, they can be secured on a wall (or on the fixed leaf) or directly on the floor.

Lower guide profile (fig. 12-13 ref. ②)

For adapting the lower profile of the leaf to the above sliding blocks.

Brush for lower guide profile (fig. 12-13 ref. ③)

Completes the on-floor guide system.

Leaf fitting profile (fig. 10 ref. ①)

Adapts the leaf's top profile to the carriage fittings.

Pair of lower sliding blocks for glass panel leaf

They enable the glass leaves to slide

2 ELECTRICAL PREPARATIONS

Route the electrical cables for connecting the accessories and electrical power supply as shown in Fig. 2.

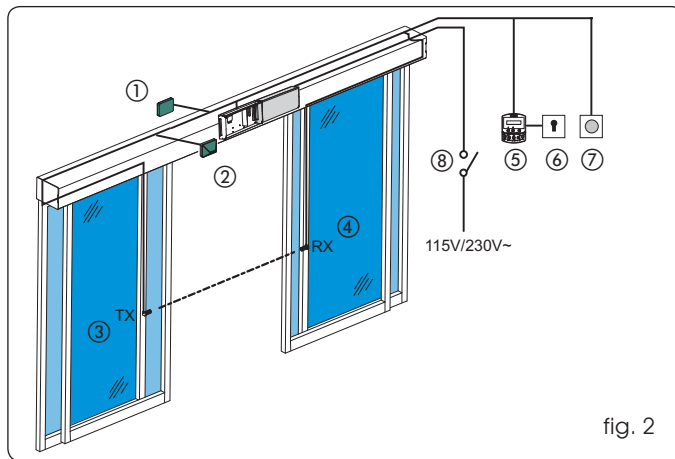

N°	DESCRIPTION	CABLES
①	External radar	4x0.25mm ²
②	Internal radar	4x0.25mm ²
③	Photocell transmitter	2x0.25mm ²
④	Photocell receiver	3x0.25mm ²
⑤	SD-Keeper / SDK-Light	2x0.5mm ² max 50 m
⑥	Key operated switch for locking SD-Keeper / SDK-Light (future accessory)	2x0.5mm ²
⑦	Control push-buttons Emerg/Key/Reset	2x0.5mm ²
⑧	Power supply 115/230V~	2x1.5mm ² + earth

3 TECHNICAL SPECIFICATIONS

MODEL	A100 COMPACT	A100 COMPACT 2
No. of leaves	1	2
Max leaf weight	110 Kg	70 + 70 Kg
Transit space (VP)	700 ÷ 3000 mm	800 ÷ 3000 mm
Max thickness of framed leaf	60 mm	
Use frequency	100 %	
Protection class	IP 23 (for indoor use)	
Operating ambient temperature	-20°C ÷ +55°C	
Power supply	115V/230 V~ 50/60 Hz	
Max absorbed power	100 W	
Beam length	Vp x 2 + 100 mm	
Drive unit	24 Vdc with encoder	
Opening speed adjustment (load free)	5 ÷ 70 cm/sec.	10 ÷ 140 cm/sec.
Closing speed adjustment (load free)	5 ÷ 70 cm/sec.	10 ÷ 140 cm/sec.
Partial opening adjustment	10% ÷ 90% of total opening	
Pause time adjustment	0 ÷ 30 sec.	
Night pause time adjustment	0 ÷ 240 sec.	
Static force adjustment	automatic	
Anti-crushing device active	at opening/closing	
Failsafe on photocells	Yes (can be activated by programming)	

4 CROSS BEAM CONFIGURATION

To suitably position the cross beam components, refer to the dimensions in figures 5, 6, and 7.

KEY TO PROFILES

ENGLISH

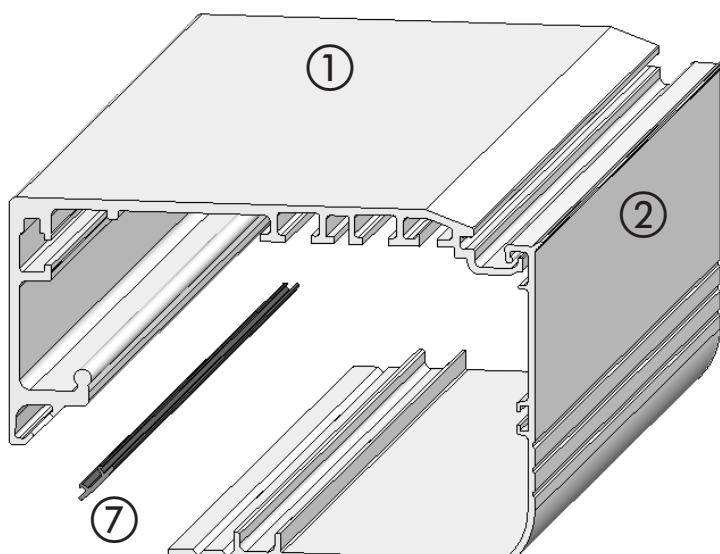

③

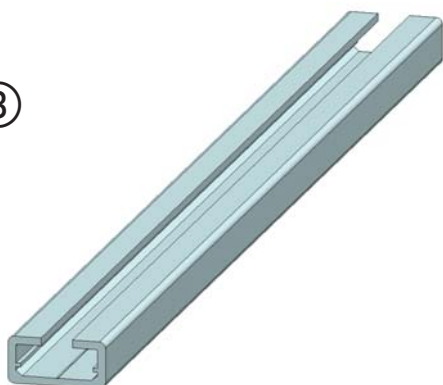

⑤

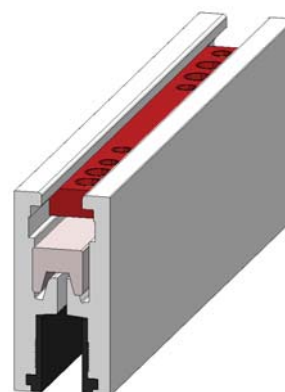

④

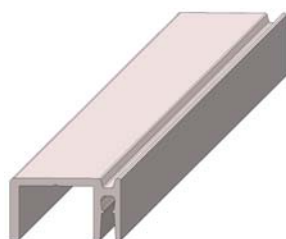

⑥

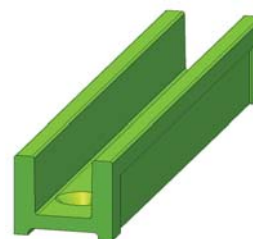

- ① SUPPORT PROFILE
- ② HOUSING PROFILE
- ③ LEAF FITTING PROFILE
- ④ LOWER GUIDE PROFILE
- ⑤ GRIPPER FOR GLASS LEAF
- ⑥ LOWER SLIDING BLOCK FOR GLASS LEAF
- ⑦ SEAL FOR COVER OF CABLE ROUTING COMPARTMENT

A100 COMPACT

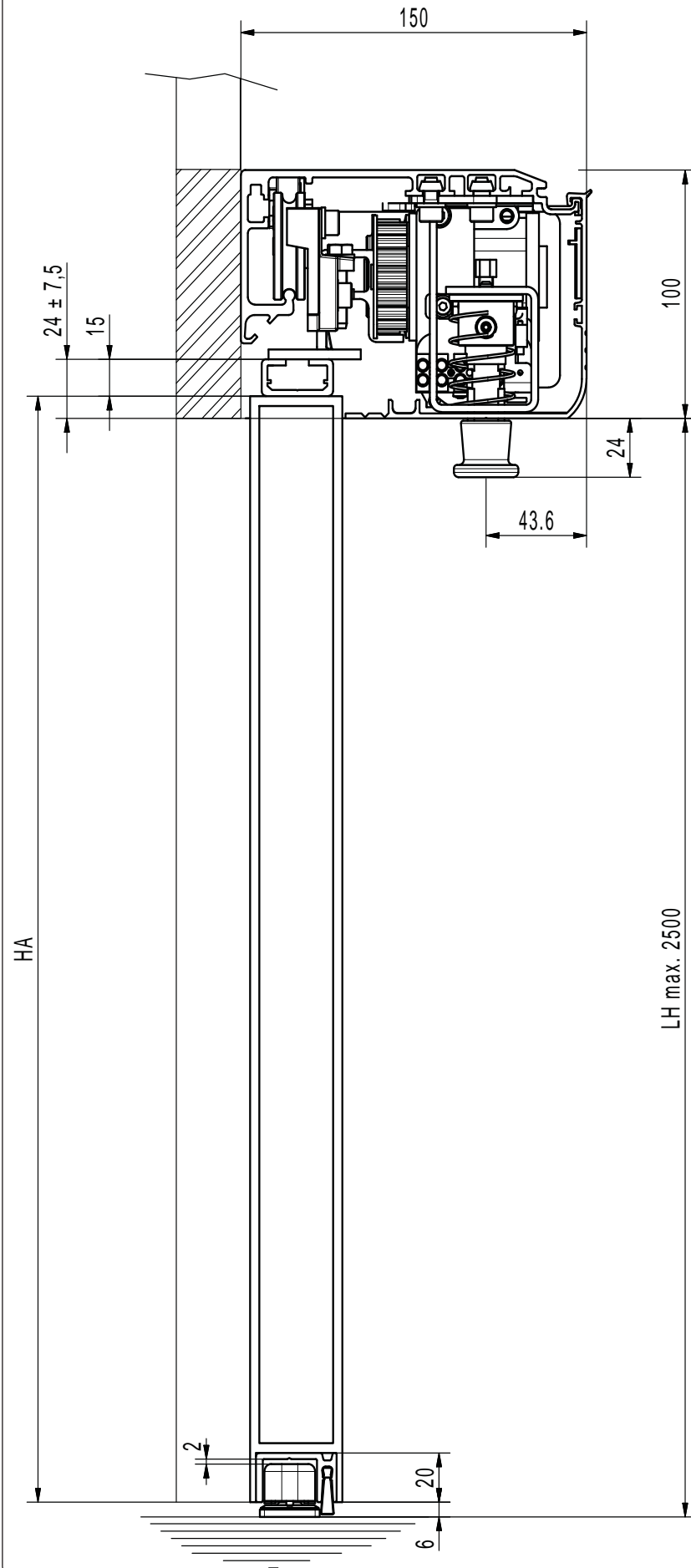

HA = (LH + 3) ± 7,5mm

HA = Leaf height

LH = height off the floor, level with lower housing side

 *The calculation of leaf height refers to the articulated sliding block. If using the fixed sliding block, refer to the specific instructions*

ENGLISH

fig. 3

A100 COMPACT glass leaf

ENGLISH

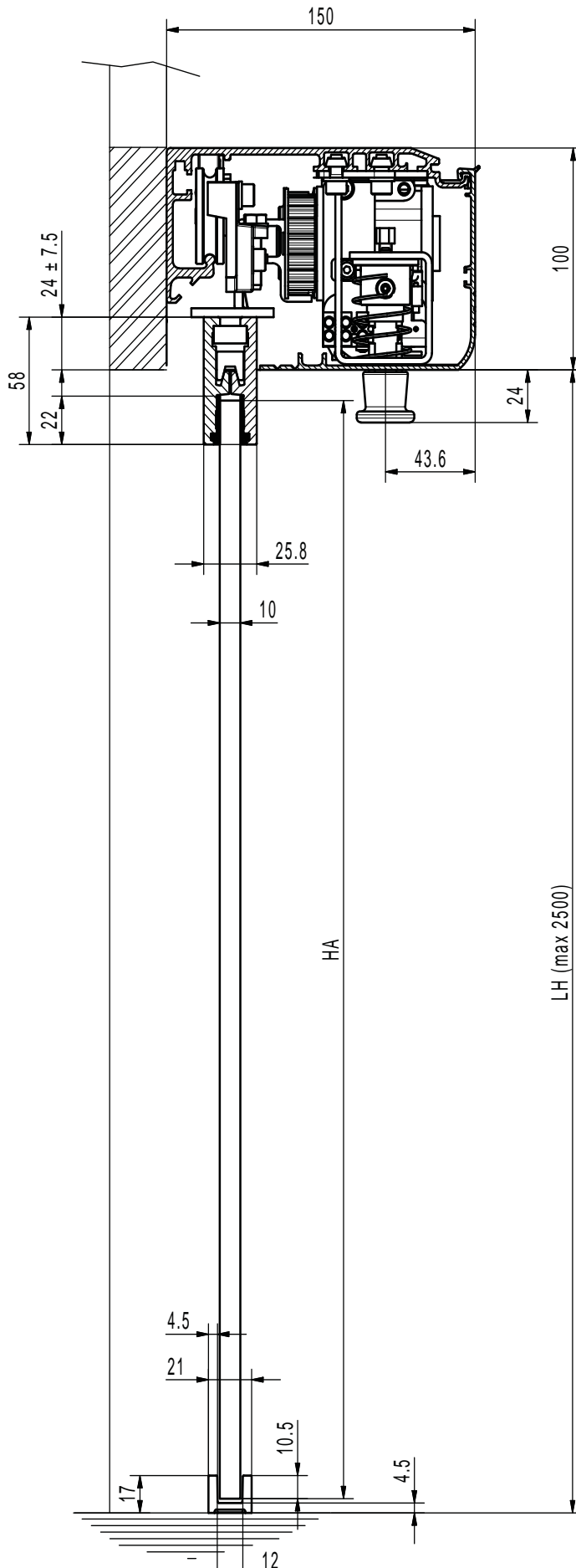

HA = (LH - 18,5) ± 7,5mm
 HA = Leaf height
 LH = height off the floor, level with lower housing side

fig. 4

A100 COMPACT Right Opening Single Leaf

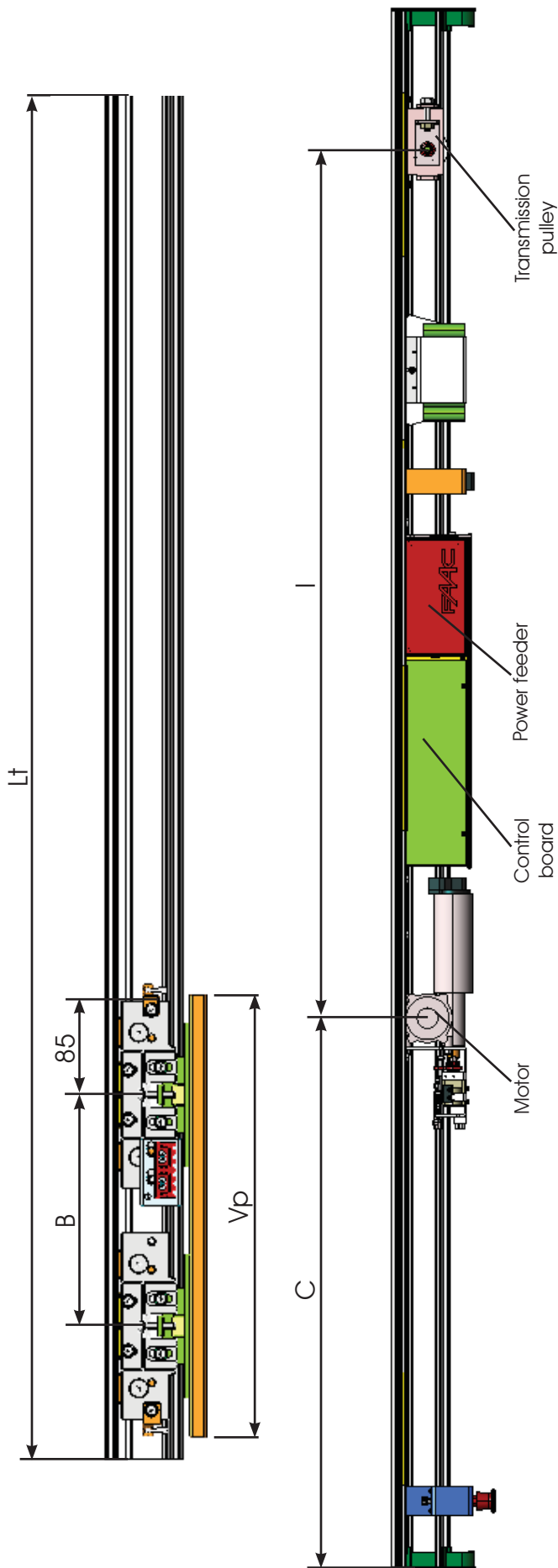

Vp	Lt	B	C	D	I
700	1500	459	425	1892	875
800	1700	559	525	2092	975
900	1900	659	625	2292	1075
1000	2100	759	725	2492	1175
1100	2300	859	825	2692	1275
1200	2500	959	925	2892	1375
1300	2700	1059	1025	3092	1475
1400	2900	1159	1125	3292	1575
1500	3100	1259	1225	3492	1675
1600	3300	1359	1325	3692	1775
1700	3500	1459	1425	3892	1875
1800	3700	1559	1525	4092	1975
1900	3900	1659	1625	4292	2075
2000	4100	1759	1725	4492	2175
2100	4300	1859	1825	4692	2275
2200	4500	1959	1925	4892	2375
2300	4700	2059	2025	5092	2475
2400	4900	2159	2125	5292	2575
2500	5100	2259	2225	5492	2675
2600	5300	2359	2325	5692	2775
2700	5500	2459	2425	5892	2875
2800	5700	2559	2525	6092	2975
2900	5900	2659	2625	6292	3075
3000	6100	2759	2725	6492	3175

ENGLISH

$$Lt = Vp \times 2 + 100$$

- B = Securing distance of carriages on sliding leaf
- C = Motor position dimension
- D = Transmission belt length
- I = Between centres distance: motor/transmission unit
- Lt = Cross beam length
- Vp = Transit space
- 100 = mm of overlap between leaves (see par.1.1B)

fig. 5

A100 COMPACT Left Opening Single Leaf

ENGLISH

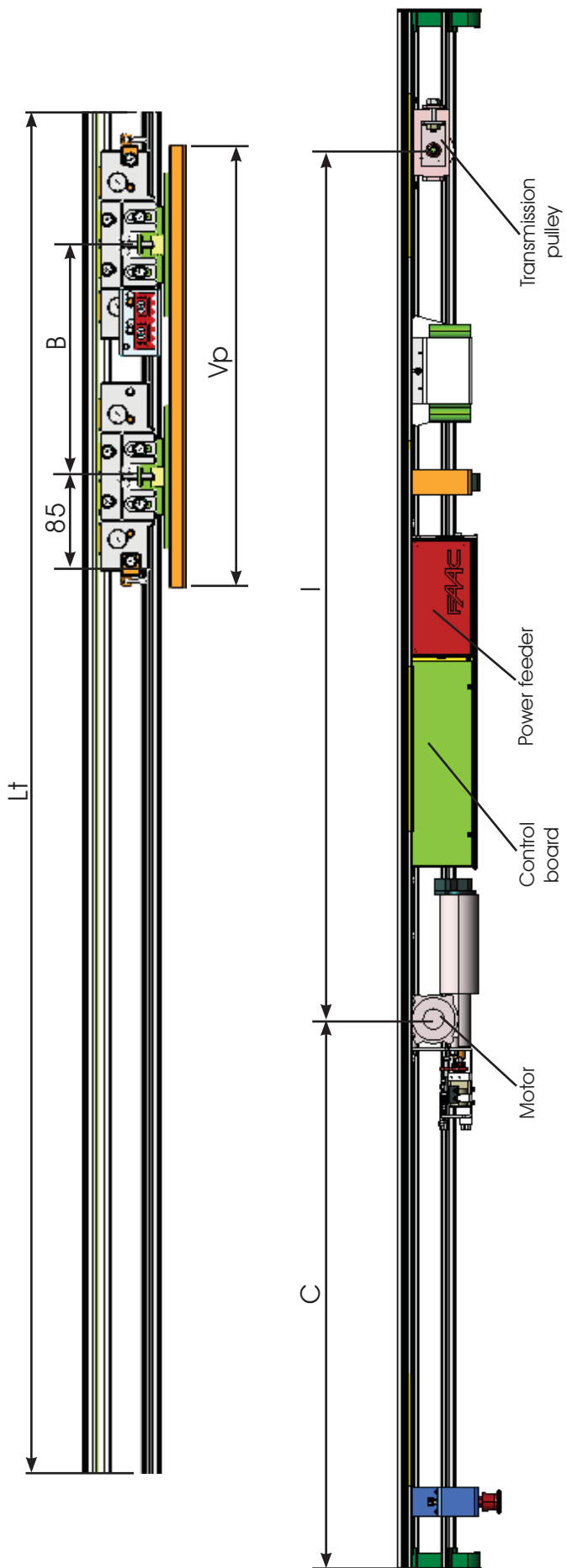

Vp	Lt	B	C	D	I
700	1500	459	425	1892	875
800	1700	559	525	2092	975
900	1900	659	625	2292	1075
1000	2100	759	725	2492	1175
1100	2300	859	825	2692	1275
1200	2500	959	925	2892	1375
1300	2700	1059	1025	3092	1475
1400	2900	1159	1125	3292	1575
1500	3100	1259	1225	3492	1675
1600	3300	1359	1325	3692	1775
1700	3500	1459	1425	3892	1875
1800	3700	1559	1525	4092	1975
1900	3900	1659	1625	4292	2075
2000	4100	1759	1725	4492	2175
2100	4300	1859	1825	4692	2275
2200	4500	1959	1925	4892	2375
2300	4700	2059	2025	5092	2475
2400	4900	2159	2125	5292	2575
2500	5100	2259	2225	5492	2675
2600	5300	2359	2325	5692	2775
2700	5500	2459	2425	5892	2875
2800	5700	2559	2525	6092	2975
2900	5900	2659	2625	6292	3075
3000	6100	2759	2725	6492	3175

$$Lt = Vp \times 2 + 100$$

- B = Securing distance of carriages on sliding leaf
- C = Motor position dimension
- D = Transmission belt length
- I = Between centres distance: motor/transmission unit
- Lt = Cross beam length
- Vp = Transit space
- 100 = mm of overlap between leaves (see par.1.1B)

fig. 6

A100 COMPACT Double Leaf

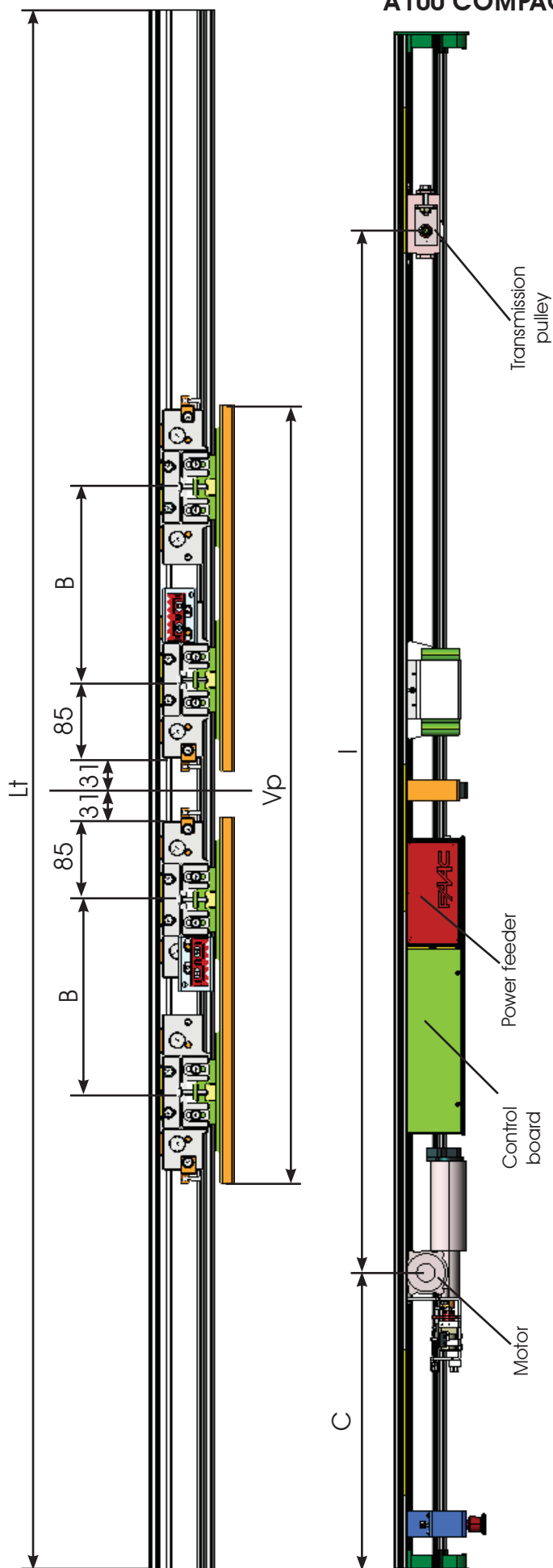

Vp	Lt	B	C	D	I
800	1700	210	205	2742	1300
900	1900	260	255	2942	1400
1000	2100	310	305	3142	1500
1100	2300	360	355	3342	1600
1200	2500	410	405	3542	1700
1300	2700	460	455	3742	1800
1400	2900	510	505	3942	1900
1500	3100	560	555	4142	2000
1600	3300	610	605	4342	2100
1700	3500	660	655	4542	2200
1800	3700	710	705	4742	2300
1900	3900	760	755	4942	2400
2000	4100	810	805	5142	2500
2100	4300	860	855	5342	2600
2200	4500	910	905	5542	2700
2300	4700	960	955	5742	2800
2400	4900	1010	1005	5942	2900
2500	5100	1060	1055	6142	3000
2600	5300	1110	1105	6342	3100
2700	5500	1160	1155	6542	3200
2800	5700	1210	1205	6742	3300
2900	5900	1260	1255	6942	3400
3000	6100	1310	1305	7142	3500

ENGLISH

$Lt = Vp \times 2 + 100$

- B = Securing distance of carriages on sliding leaf
- C = Motor position dimension
- D = Transmission belt length
- I = Between centres distance: motor/transmission unit
- Lt = Cross beam length
- Vp = Transit space
- 100 = mm of overlap between leaves (see par.1.1B)

fig. 7

A. INSTALLATION OF ASSEMBLED AUTOMATED SYSTEM

1A PREPARING THE SUPPORT PROFILE

The support profile is used to secure the automated system to a load bearing structure in metal or masonry, free of any significant deformation.

Position the cross beam on the floor, withdraw the 'parachute' cables from the housing (Fig. 26 ref. ⑤), and remove the housing. If necessary, remove from the profile also those components (e.g. motor, carriages, transmission pulley) which could hamper you while securing to the wall, loosening the nuts from the plates. To then position the removed parts, refer to figures 5-6-7.

1.1A SUPPORT PROFILE - SECURING ON WALL

Define the exact height position of the support profile, considering the dimensions of fig.3 and - for doors with glass leaves - in fig.4.

 **The cross beam must be fastened parallel to the floor.**

Initially fix the support profile on a vertical slot at one end, and on a horizontal slot at the other end (using M8 screws and appropriate expansion plugs which are not supplied) and level parallel to the floor. Fasten centrally, lifting the support profile with force to align the three securing points. Carry out the remaining fastenings.

ENGLISH

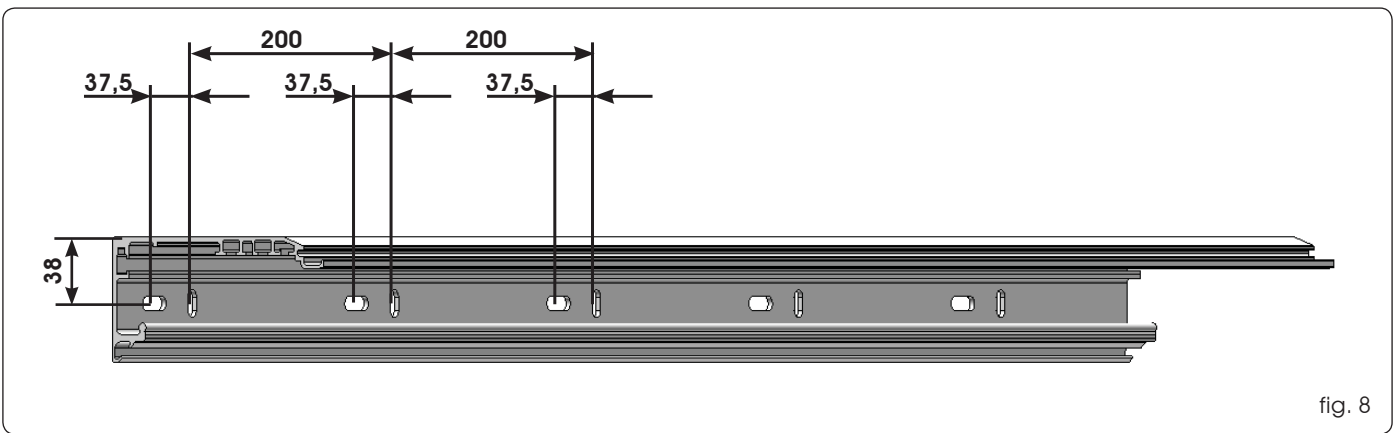

fig. 8

2A PREPARING THE LEAVES

Prepare the leaves as described below.

1. Secure to the leaf, the leaf fitting profile cut to the same length, and secure it with adequate screws on the upper part (fig. 9).
2. Position two carriages on each leaf, using the supplied plates and screws as shown in Fig. 10.
3. Secure the carriages on the leaf, using the dimensions in figure 7 for the double leaf, and fig. 5-6 for the single leaf. Tighten the carriage securing screws.
4. Cut the lower guide profile to the same length as the leaf and secure with adequate screws on the lower part (fig.11).
5. If specified, insert the brush in the seat of the sliding profile Fig. 11 ref. ①.

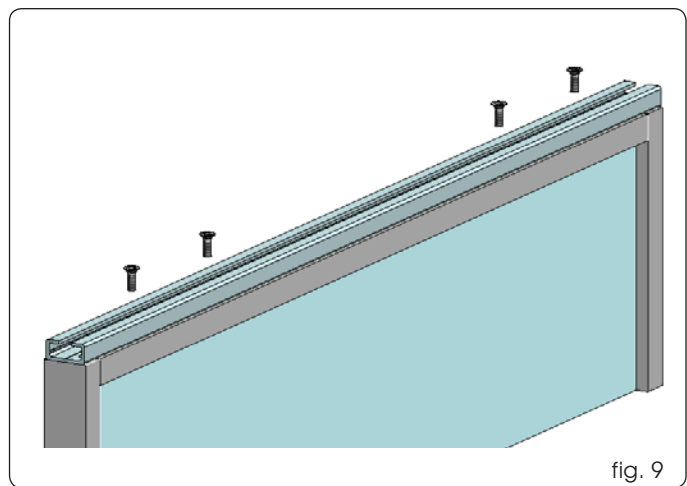

fig. 9

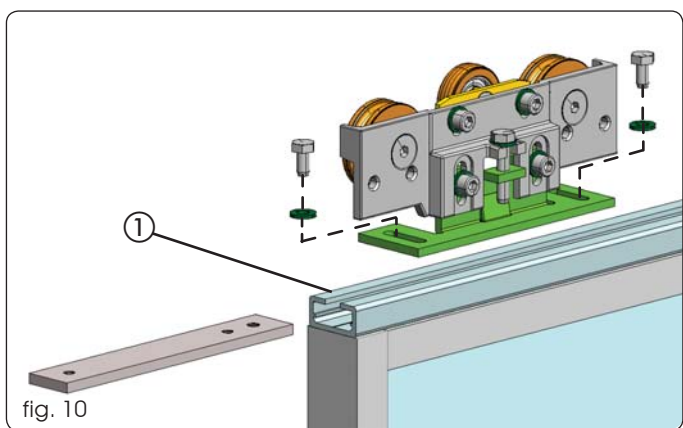

fig. 10

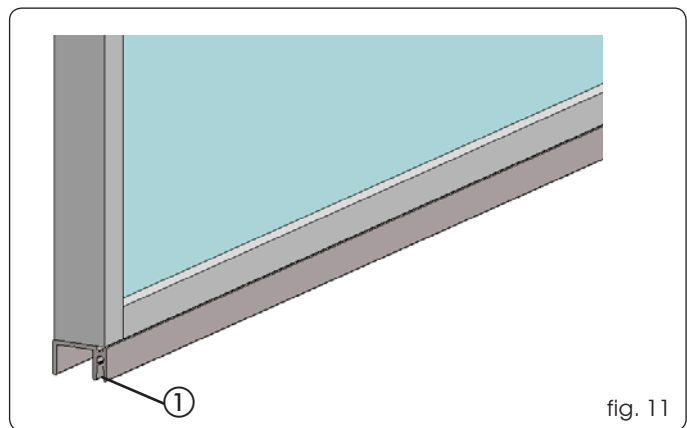

fig. 11

3A INSTALLING THE LOWER SLIDING BLOCKS

The lower sliding blocks are designed for securing to a wall (or fixed leaf) or to the floor.

Assemble the sliding blocks, referring to the dimensions in figures 12 and 13.

On-wall securing (or on fixed leaf):

- Secure the sliding blocks as shown in Fig. 14 ref. ①, using adequate screws.

Securing on the floor

- Directly secure the sliding block to the floor, as shown in Fig. 14 ref. ②, using adequate expansion plugs and screws.

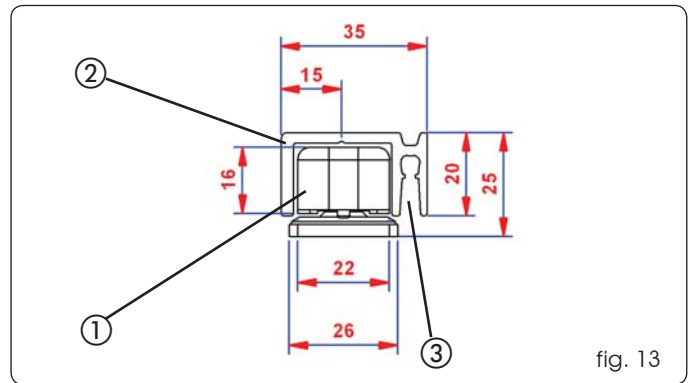

fig. 13

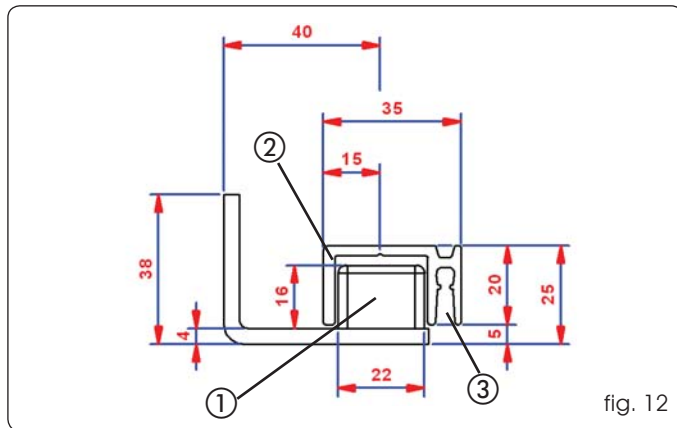

fig. 12

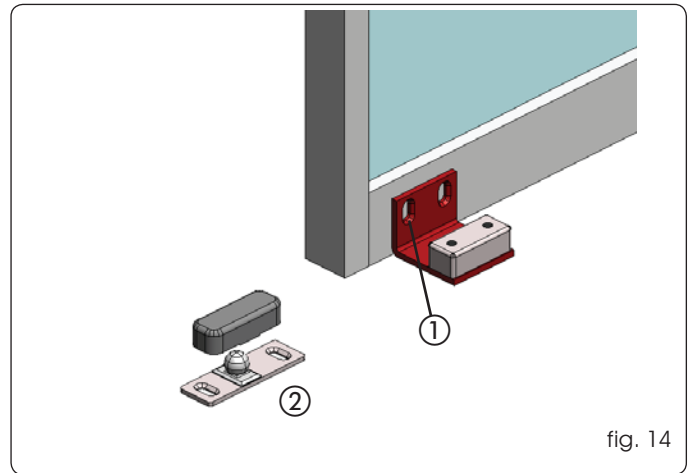

fig. 14

4A ADJUSTING THE LEAVES

When you have prepared the leaves, install them on the support profile.

The carriages have two sliding wheels (Fig.15 ref. ①) and a counter-thrust wheel (Fig.15 ref. ②)

Two slots are provided on the base of the carriages. These slots enable leaf depth adjustment (Fig.15 ref. ③)

4.1A LEAF HEIGHT ADJUSTMENT

The carriages allow leaf height adjustment of ± 7.5 mm. Adjustment procedure:

- Slightly loosen the two cylinder head screws - fig.15 ref.④.
- Turn the screw (fig.16) clockwise to raise the leaves or anti-clockwise to lower them.
- Tighten the two cylinder head screws you had loosened

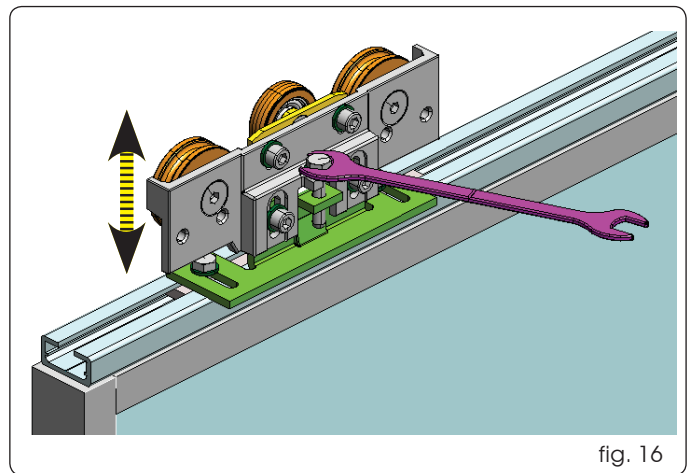

fig. 16

4.2A LEAF DEPTH ADJUSTMENT

To adjust the depth of the leaves, loosen the screws as shown in Fig. 17.

Move the leaf on the carriage slot as you require and tighten the screws.

Make sure that the leaves are parallel with respect to the support profile.

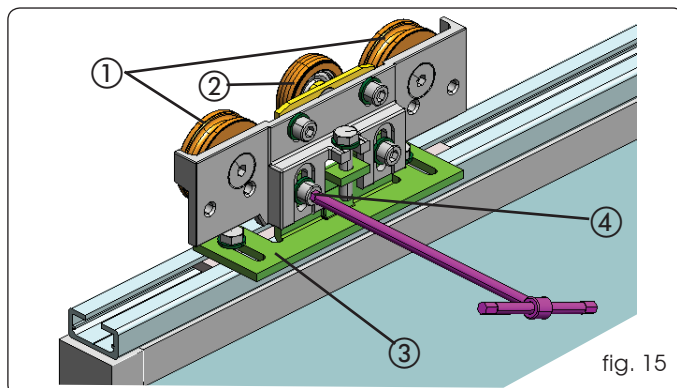

fig. 15

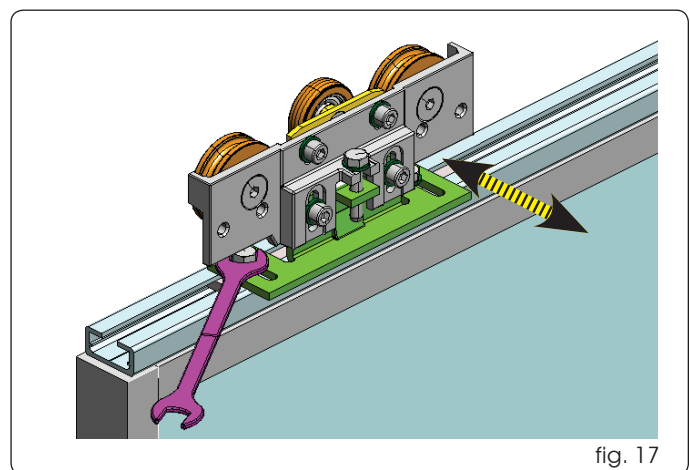

fig. 17

4.3A ADJUSTING THE COUNTER-THRUST WHEEL

The carriages have a counter-thrust wheel which prevents them from coming out of their seat.

 **The wheel must be adjusted so that it does not press on the support profile, to thus avoid increased friction.**

Counter-thrust wheel adjustment procedure:

- Loosen the two cylindrical screws (Fig. 18 ref. ①).
- Adjust the height of the wheel support, making it come as close as possible to the main profile without touching it (Fig. 18 ref. ②).
- When you have adjusted the wheel's height, tighten the two cylindrical screws (Fig. 18 ref. ①).

If necessary, use a shim of about 0.5 mm, placing it between the wheel and the main profile, removing it when you have finished the adjustment.

Move the leaves by hand and check if the counter-thrust wheel is free to move without grazing.

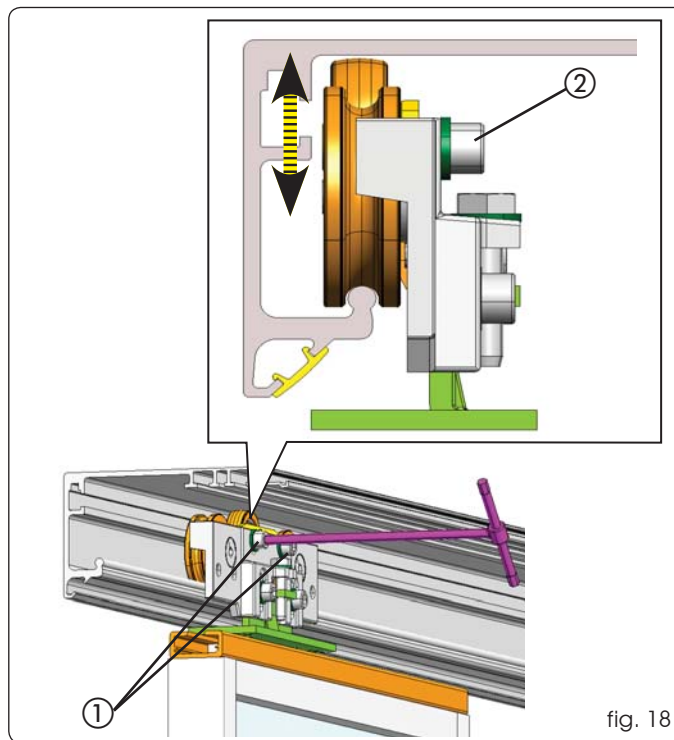

fig. 18

5A ADJUSTING THE OPENING MECHANICAL STOPS

The automatic door is supplied with the opening mechanical stops installed on the support profile. As the leaves open, make sure that the carriages come into contact with the mechanical stops. If adjustments are required, proceed as follow:

- Loosen the securing screws of the mechanical stops (Fig. 19 ref. ①) and take them to the ends of the support profile.
- Take the leaf or leaves into opening position (fig. 20), take the mechanical stop near to the carriage until the two parts touch and tighten the lock nut (Fig. 20 ref. ①).

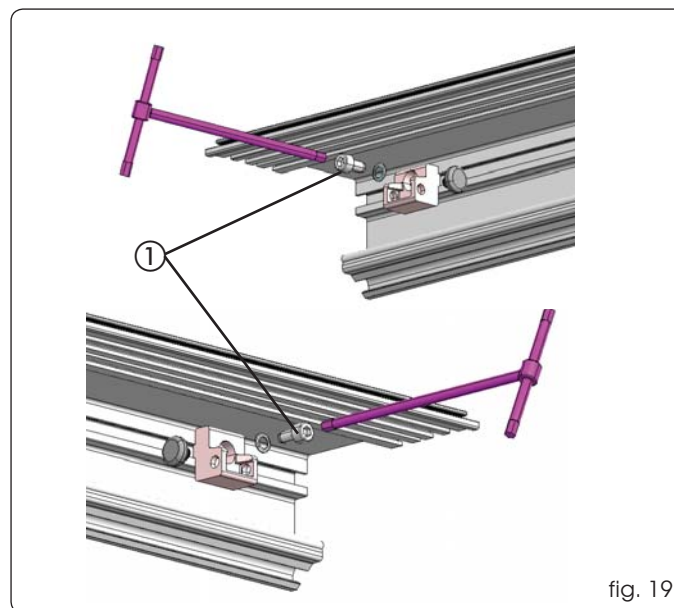

fig. 19

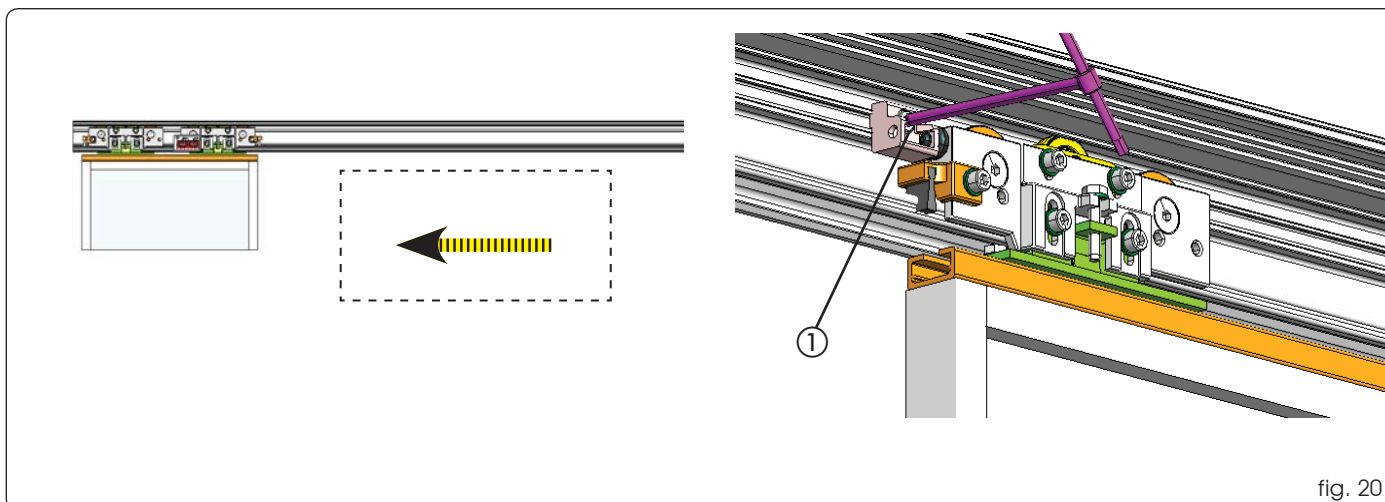

fig. 20

6A ADJUSTING THE CLOSING MECHANICAL STOPS (DOUBLE LEAF)

The automatic door is supplied with the closing mechanical stops installed on the mid-point of the support profile. If the door centre requires adjustment, proceed as follows:

- Check if the mechanical stops are at the centre of the profile.
- Take the leaf or leaves into the closing position.
- Loosen the securing screws of the carriages (Fig.21 ref.①).
- Take the carriage close to the contact point until the two touch.
- Re-tighten the carriage securing screws.

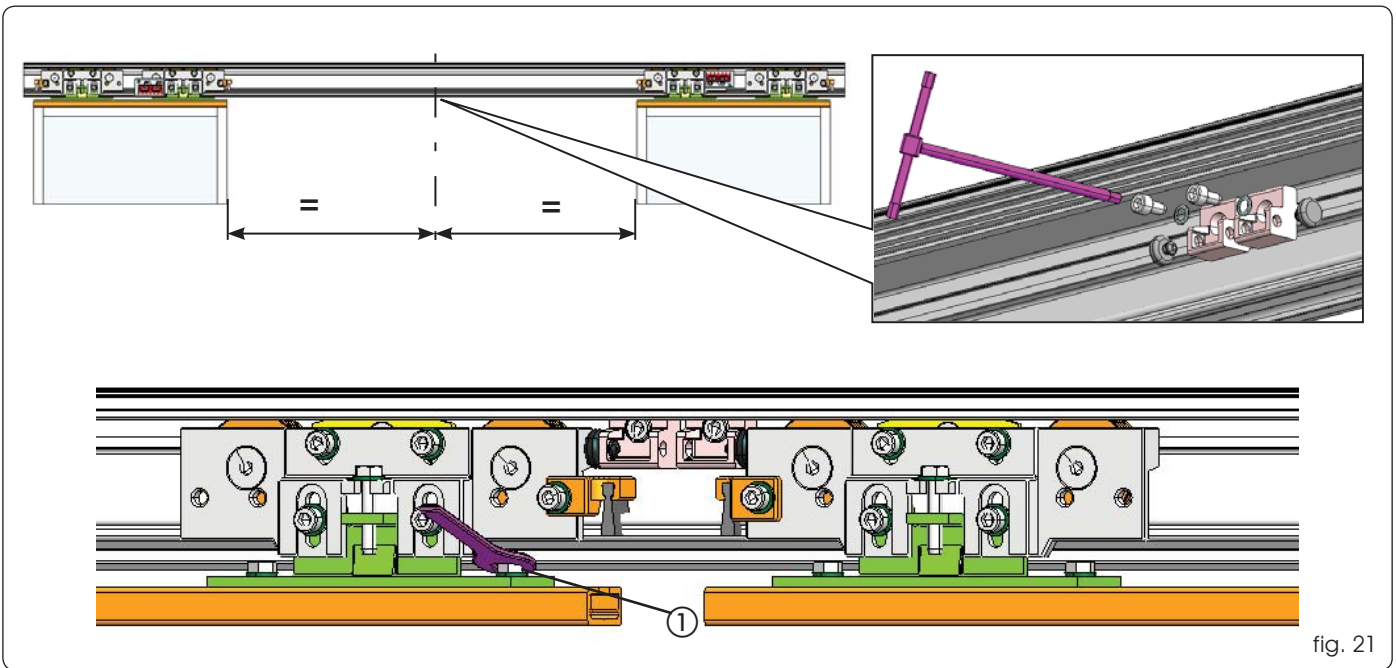

fig. 21

6.1A ADJUSTING THE CLOSING MECHANICAL STOPS (SINGLE LEAF)

The automatic door is supplied with the closing mechanical stops installed on the support profile. As the leaves close, make sure that the carriages come into contact with the mechanical stops. If adjustments are necessary, proceed as indicated for the opening mechanical stops (chap 5A).

7A ADJUSTING THE BELT FASTENING ON CARRIAGES

The automated system is supplied with the belt fastened to the carriages by the fastening fittings (Fig. 22 ref. ③) It is usually unnecessary to modify this fastening, but, if it is necessary to adjust finely, proceed as follows:

- Take the automated system into closing position.
- Turn the two pairs of screws (Fig. 22 ref. ① and ②) of each carriage to obtain the required adjustment.
- Tighten the screws (Fig. 22 ref. ① and ②) .
- Check if the closing contact point between the two leaves corresponds to the support profile mid-point and if the leaves are able to open and close completely.

ENGLISH

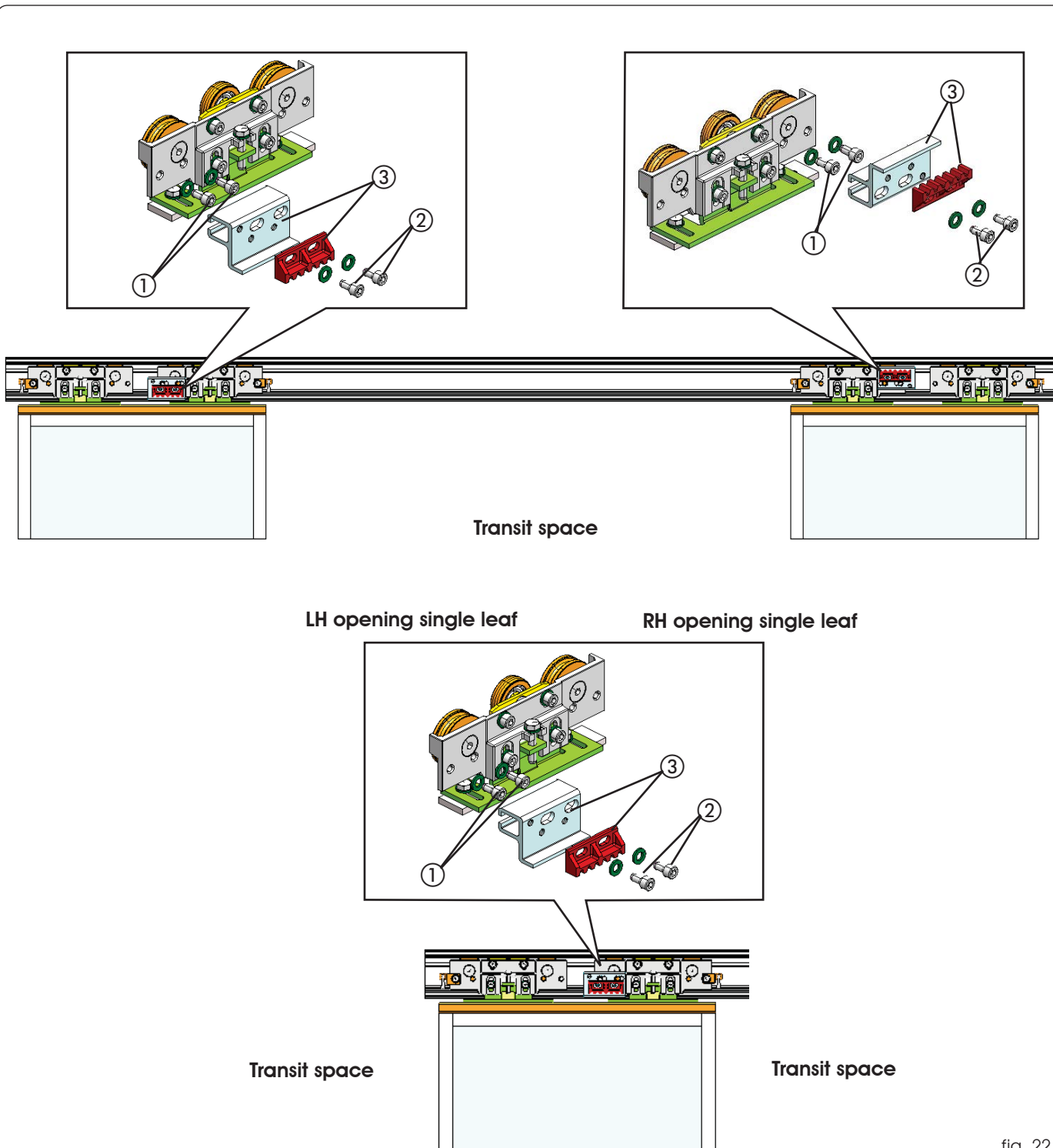

fig. 22

8A ADJUSTING BELT TENSION

Make sure that the belt is not too loose or too taut.
Belt tensioning procedure:

- Loosen the nut (Fig. 23 ref. ①).
- Turn the screw and bolt (Fig. 23 ref. ②) to tighten or loosen the belt.
- After controlling tension, tighten the nut (Fig. 23 ref. ①)

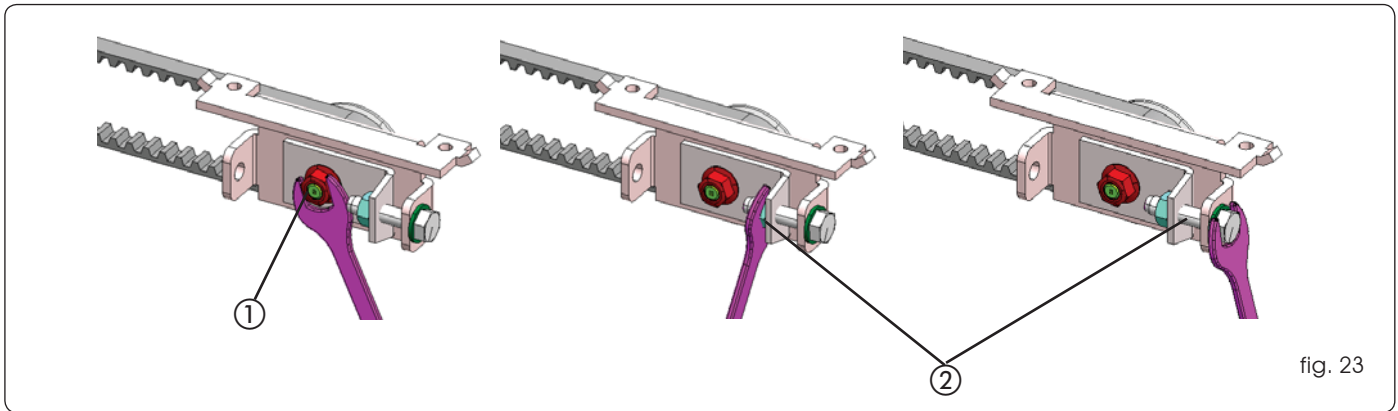

fig. 23

9A INSTALLING THE PARACHUTE AND THE SPACERS

Check if the parachute cables are present, and, if necessary, secure them on the two ends of the support profile, housing the bigger end of the cable in the seats (Fig. 24 ref. ①).

Check if the three anti-vibration spacers (Fig. 24 ref. ②) are present, and, if necessary, insert them on the outer edge of the support profile, positioning them at the ends and centrally (for profiles of over 3 meters).

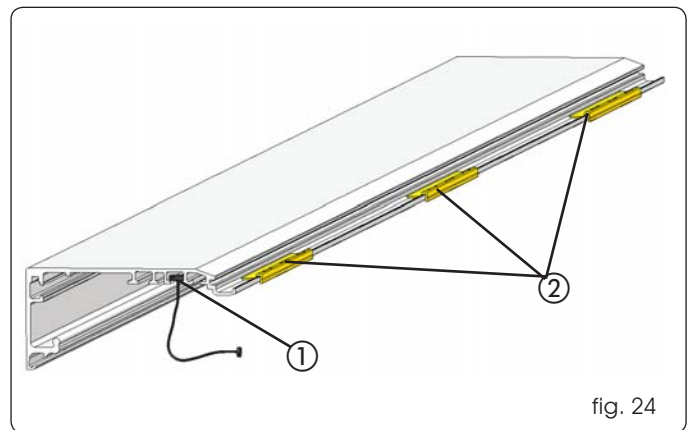

fig. 24

10A INSTALLING THE SIDE PANELS

Fit the side panels as shown in Fig. 25. ref.①. The figure shows the installation of the right hand side panel - proceed in the same way for the left panel.

If you do not wish to install the side panels, install 3 brackets to secure the housings - two at the sides and one in the centre (for profiles of over 3 meters) as shown in Fig. 25 ref. ②.

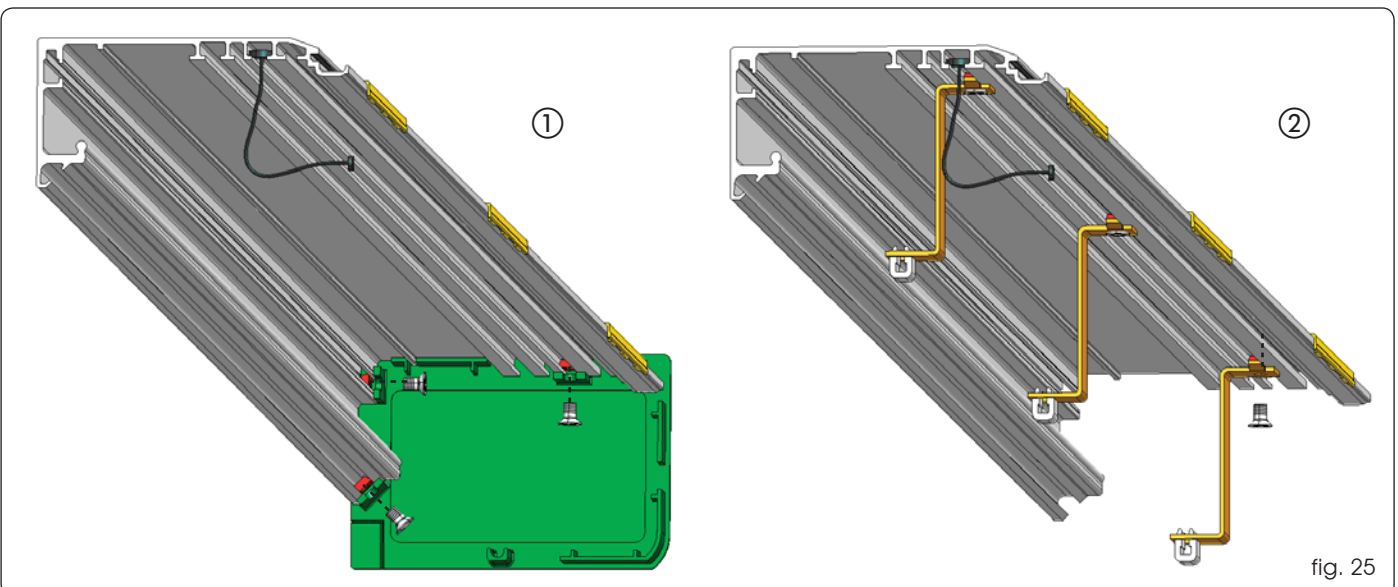

fig. 25

ENGLISH

11A INSTALLING THE CLOSING HOUSING

- Lay the closing housing on the spacers you had previously mounted, as shown in Fig. 26 ① or ②.
- To keep the housing open, lift it (Fig. 26 ref. ③) and push it (Fig. 26 ref. ④) toward the profile until the metal protrusion fits in the profile seat.
- Secure the parachute cables in the appropriate seats (Fig. 26 ref. ⑤)
- The closing housing is locked in line with the two side panels or the securing brackets (Fig. 26 ref. ⑥)
- The closing housing is pre-marked to adapt it to different leaf thickness values. Eliminate excess profile by cutting at the points indicated in fig. 26 ref. ⑦.



If you are using the internal release, in order to close the housing correctly, drill a hole near the release knob as shown in paragraph 16B.

ENGLISH

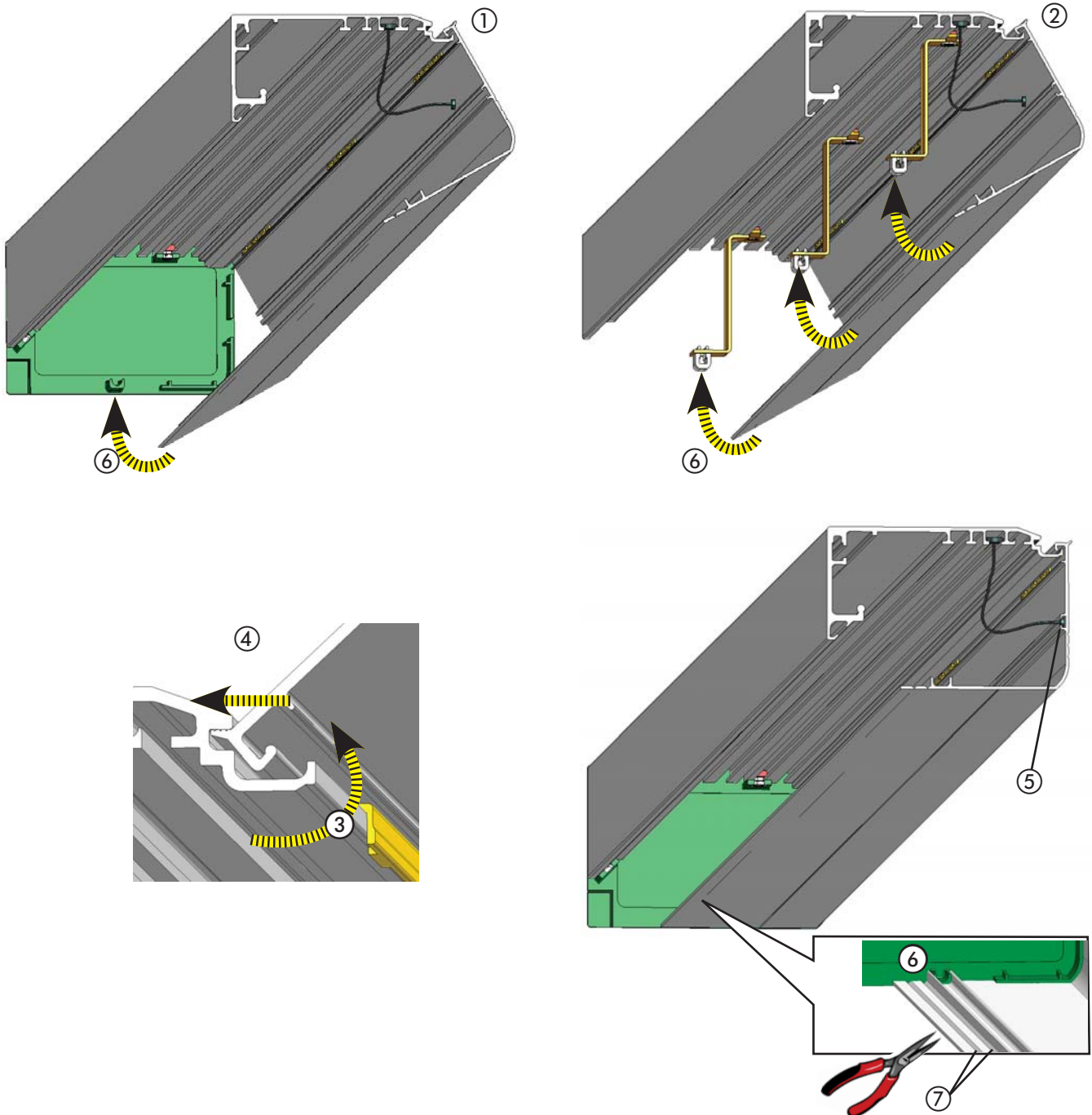

fig. 26

12A MOTOR LOCK

The motor locking device guarantees that the leaves are locked when closed. If requested when ordering, the motor locking device is supplied pre-installed on the support profile of the automated system and includes the knob operated internal release system.

Adjustment procedure for the motor locking device:

- Close the leaves.
- Manually push the lever (fig. 27 ref. ①) toward the motor shaft, checking correct coupling as shown in fig. 27, ref.A).
- Move the lever (fig.27 ref.②) vertically and look for any play between the motor shaft and motor lock coupling.

If there is no play, proceed as follows:

- Loosen the two screws (fig. 28 ref.①) which connect the belt fitting to the drive carriage (on both carriages for double leaves).
- Gently move the belt coupling horizontally, until the lever moves freely; tighten the screws you had loosened.

If installing later on, refer to chapter 13B. For programming, consult the part of these instructions referring to the control board.

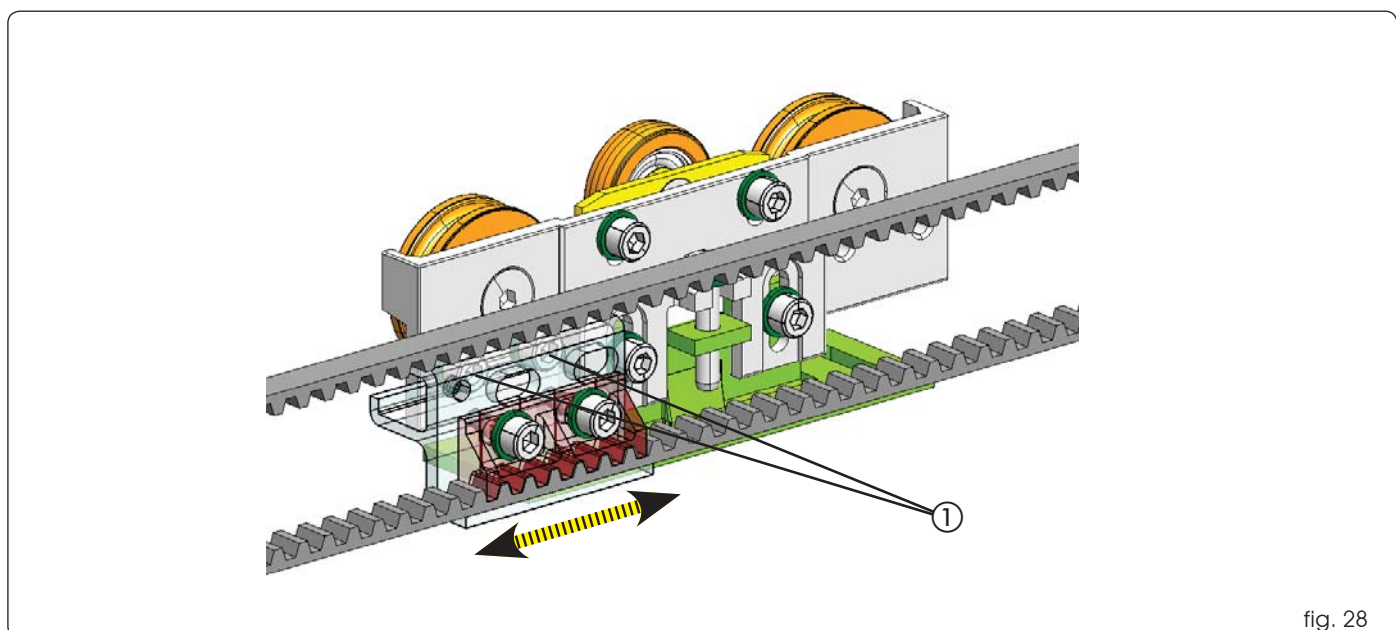
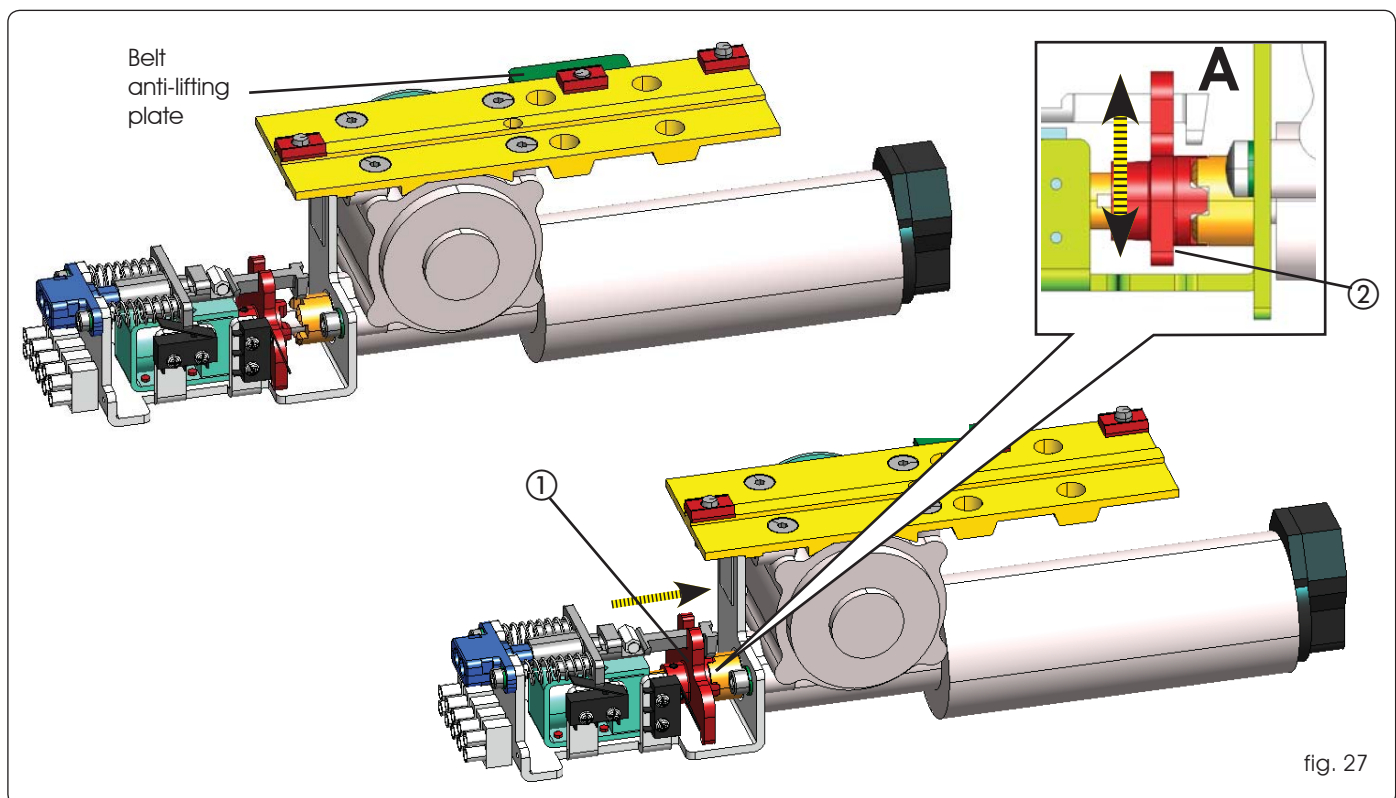

ENGLISH

13A START-UP OF THE AUTOMATED SYSTEM

- Manually check correct sliding of the leaves and of all the moving elements.
- Carry out/check the electrical connections on the control board of the power cables coming from the power supply unit, from the motor, and from all accessories, consulting the instructions of the control board.
- Use the raceways - suitably positioned (Fig. 29 ref.① and ②) - to route the cables inside the support profile, thus preventing them from coming into contact with moving parts.
- Set motor rotation direction according to type of door (refer to the control board instructions).
- Connect the 115V/230V~ power plug in the specific connector of the power supply unit (Fig. 29 ref. ③).

⚠ Check if the switch in fig. 29 ref.④ is correctly positioned (230V~/115V~).

- Check the efficiency of all installed accessories, especially photocells and sensors.

ENGLISH

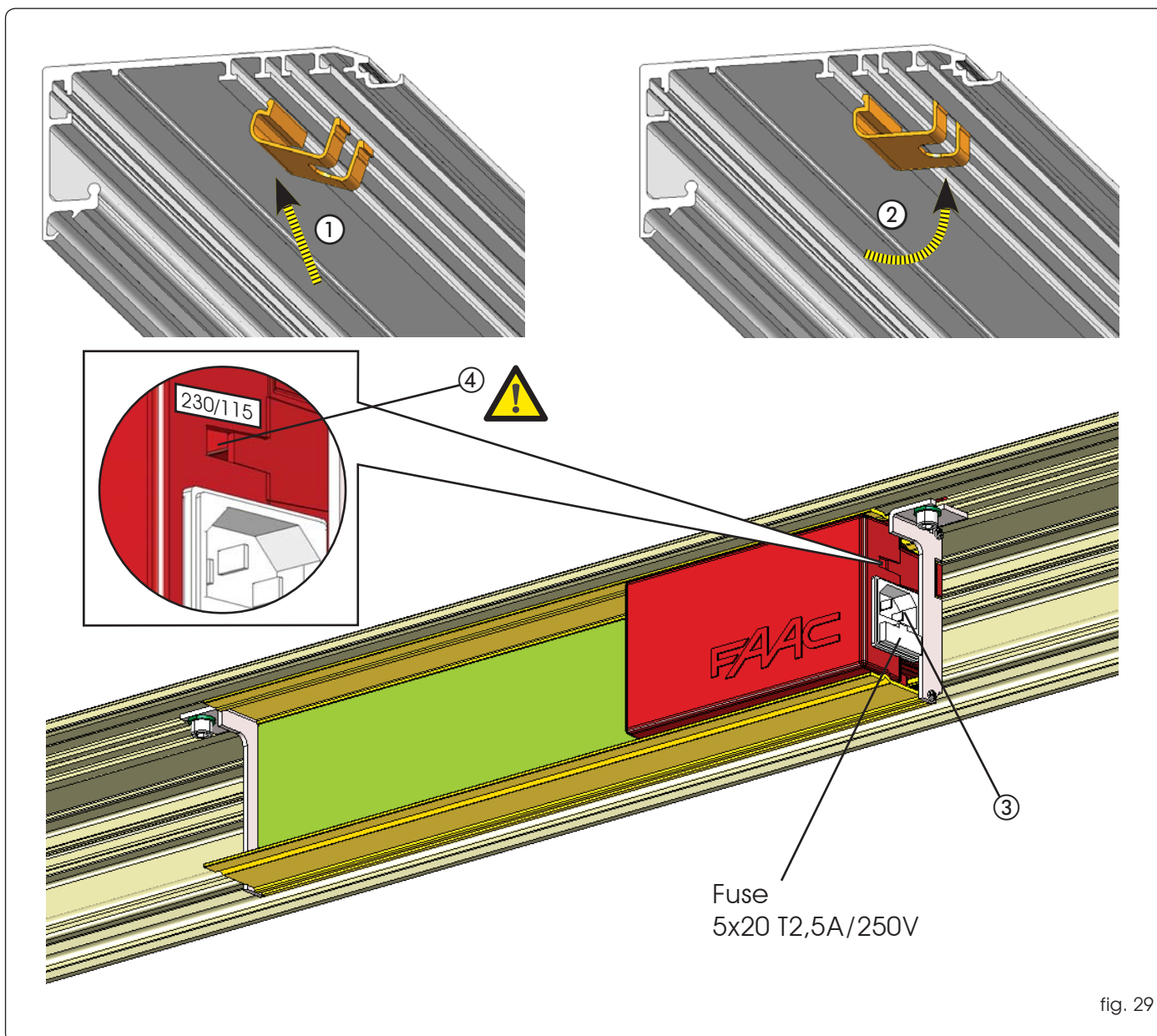

fig. 29

B. ASSEMBLY OF IN-KIT AUTOMATED SYSTEMS

This section describes the assembly of the in-kit automated systems. After you have prepared the necessary profiles, we advise you to assemble and install at the same time.

1B PREPARING THE SUPPORT PROFILE

Support profiles are available in two sizes:
4300 mm or 6100 mm.

Cut the support profile to measure using the following formula:

$$LT = Vp \times 2 + 100$$

Where:

- **Lt** is the length of the support profile
- **Vp** is the transit space
- **100** are the overlap millimeters between the leaves (50 + 50)

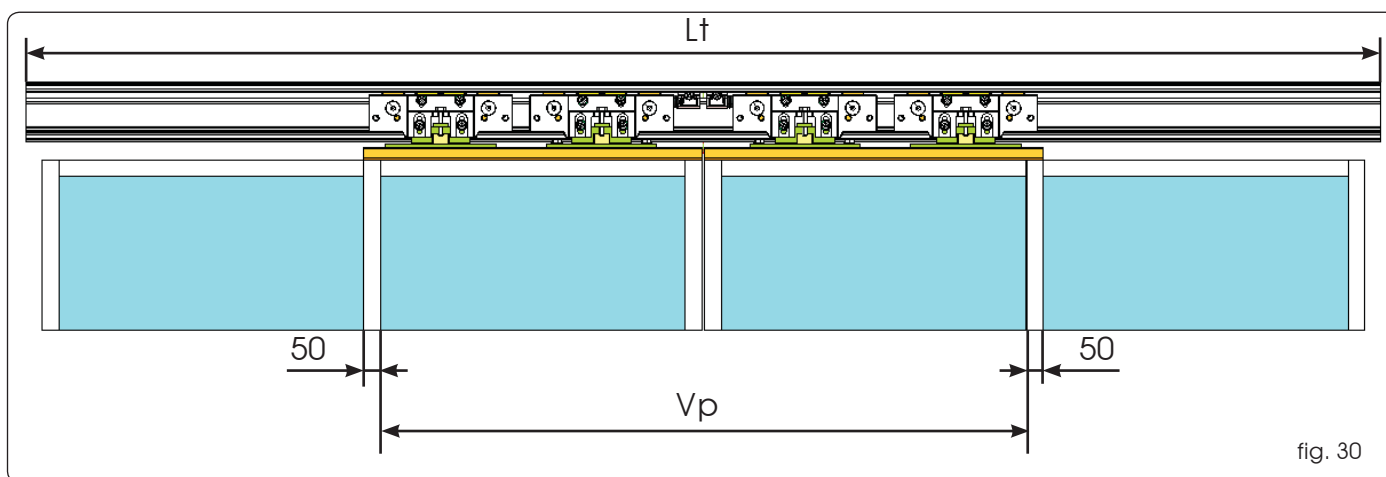

1.1B SECURING THE ON-WALL SUPPORT PROFILE

Refer to chapter 1.1A of the assembled automated system installation.

1.2B SECURING COMPONENTS TO THE PROFILE

The accessories are secured to the profile by using the supplied plates. They can be fitted into their seats both laterally and on any point of the profile (fig. 31).

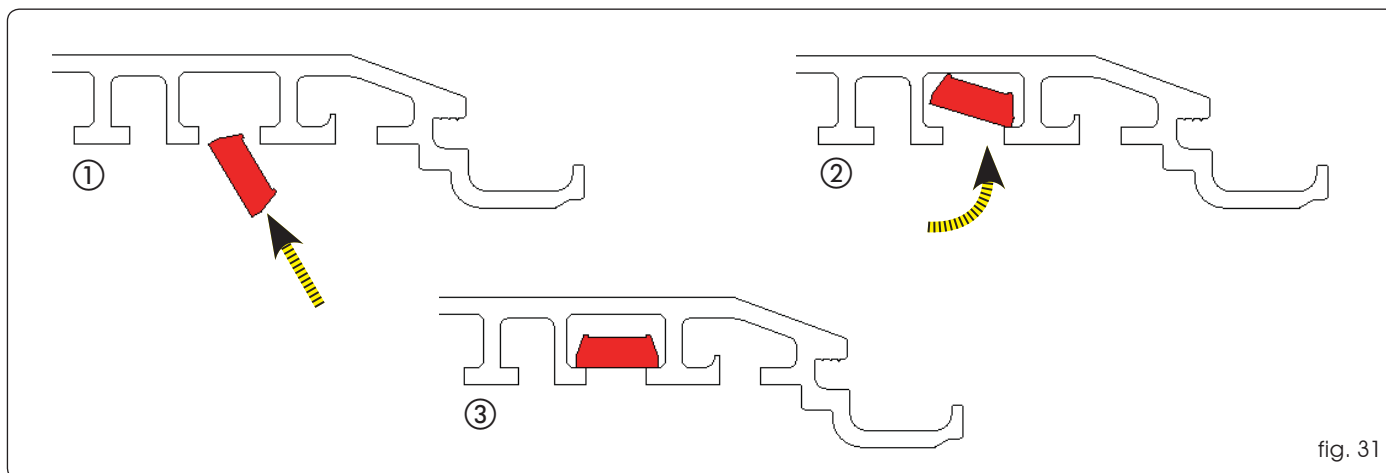

1.3B POSITIONING OF THE LIMIT SWITCH.

Fit four plates on the ends of the support profile (fig.32), two for the central stops and two for the side stops.

ENGLISH

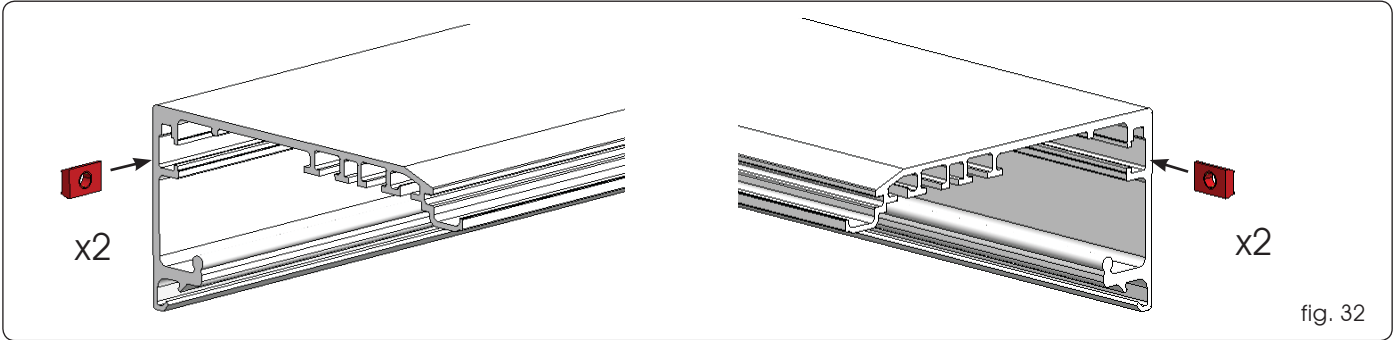

Install the mechanical stops as shown in Fig. 33, using the supplied screws.

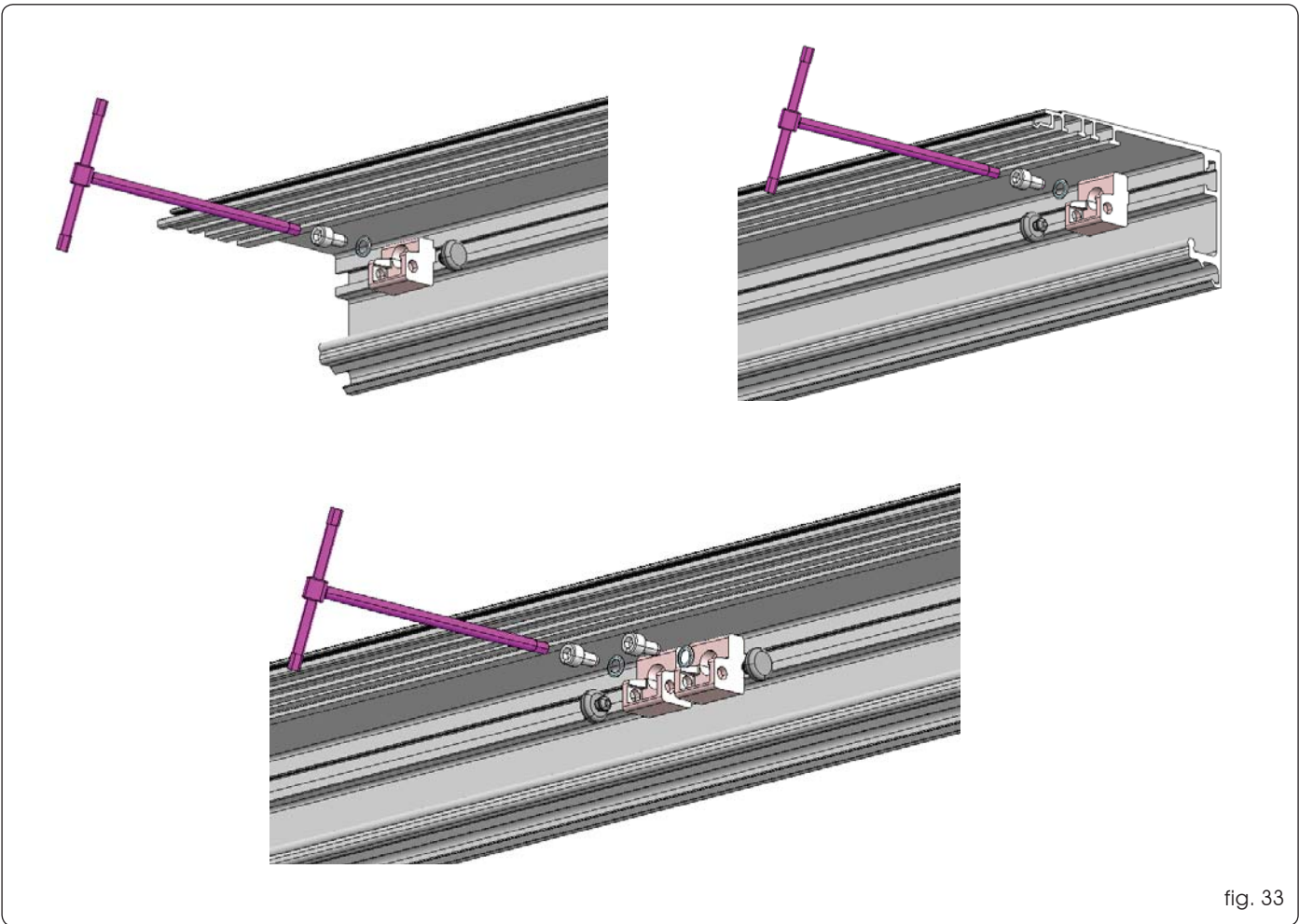

2B PREPARING THE LEAVES

Refer to chapter 2A of the assembled automated system installation.

3B INSTALLING THE LOWER SLIDING BLOCKS

Refer to chapter 3A of the assembled automated system installation.

4B ADJUSTING THE LEAVES

Refer to chapter 4A of the assembled automated system installation.

5B ADJUSTING THE MECHANICAL STOPS

Refer to chapter 5A and 6A of the assembled automated system installation.

6B INSTALLING THE BELT FITTINGS AND BRUSHES

Double leaf automated systems:

Install two belt fittings on the more internal carriages and brushes as shown in Fig. 34 ref. A.

Single leaf automated systems:

Fit the belt fitting and the brushes as indicated in fig. 34 ref. B.

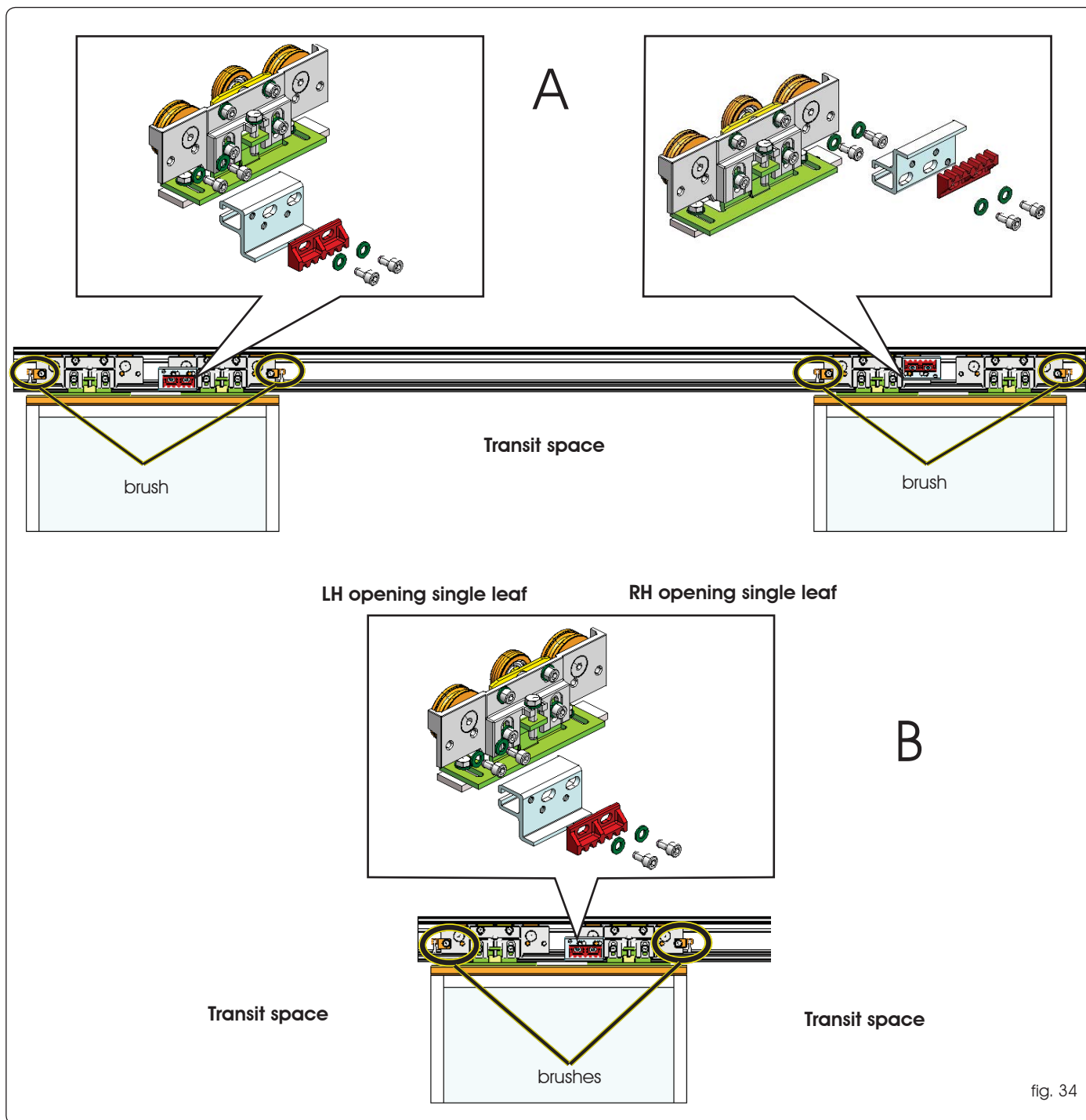

fig. 34

8B ADJUSTING THE BELT FASTENING

Refer to chapter 7A of the assembled automated system installation.

10B INSTALLING THE CABLE RACEWAYS

Install by pressure the cable raceways in the seat of the support profile as shown in Fig. 35.

9B ADJUSTING BELT TENSION

Refer to chapter 8A of the assembled automated system installation.

ENGLISH

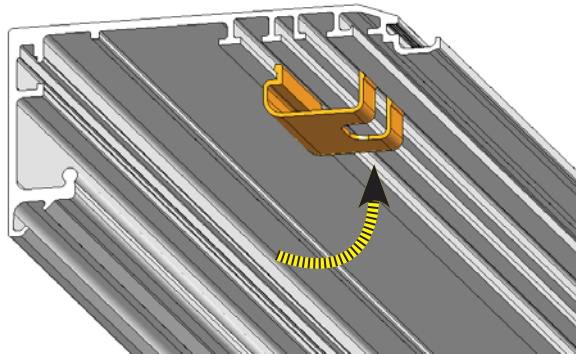
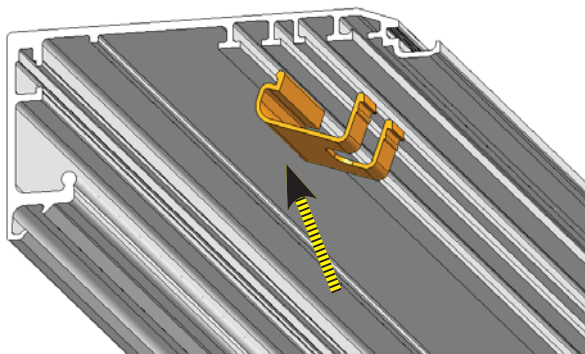

fig. 35

11B INSTALLING THE PARACHUTE AND SPACERS

Proceed as described in chapter 9A of the assembled automated system installation.

12B INSTALLING THE SIDE PANELS AND BRACKETS

To install the side panels and the central bracket (for profiles of over 3 meters) (fig.36), place 8 plates on the profile of the support profile. Fit 4 of them on one side of the support profile and 4 on the other.

If you do not wish to install the side panels, install 3 brackets to secure the housings - two at the sides and one in the centre (for profiles of over 3 meters), and instead of the 3 side plates, fitting only one as shown in Fig. 36 ref. ①.

Secure the side panels and brackets as shown in chapter 10A of the assembled automated system installation.

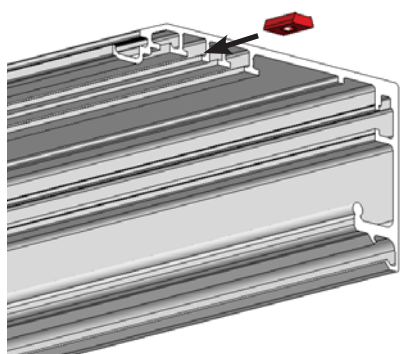

Plates for central bracket

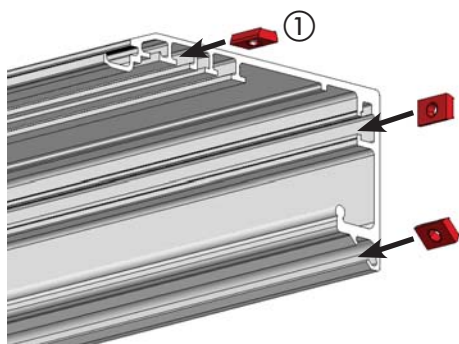
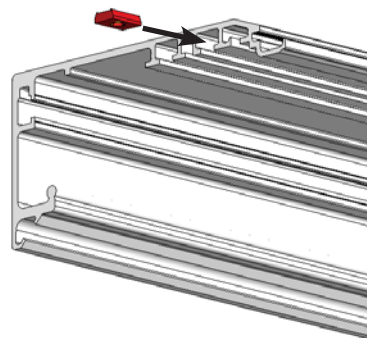

Plates for side panels / side brackets

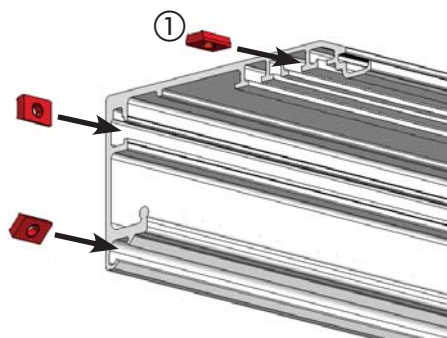

fig. 36

13B INSTALLING THE MOTOR LOCK

Install the motor lock, using the supplied screws as shown in Fig. 37 ref. ①.

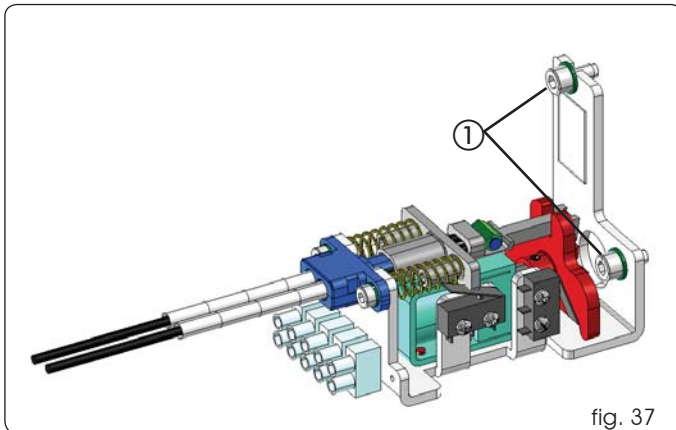

fig. 37

13.1B ADJUSTING THE MOTOR LOCK

Adjust the motor lock as described in chapter 12A of the assembled automated system installation.

13.2B INSTALLING THE INTERNAL RELEASE KNOB

DOUBLE LEAF APPLICATIONS:
For $V_p = (800 \div 1000)$ mm, we advise you to install the release knob on the side opposite the motor.
For $V_p = (1000 \div 3000)$ mm, we advise you to install the release knob on the same side as the motor.

- Assemble the release knob on the side bracket, as shown in Fig. 38, after inserting two plates in the profile (Fig.38 ref. ①)
- Screw the adjuster, with the relevant lock nut, as shown in Fig. 39 ref. ①.
- Take about 20 cm of steel cable from the sheath.
- Insert the steel cable inside the adjuster; route it inside the release device (Fig. 39 ref.②).
- Secure the steel cable with the clamp and tighten the screw (fig. 39 ref.③).
- Take the black sheath of the cable in contact with the adjuster (fig. 39 ref.①).
- Fully screw the adjuster on the bracket.
- Lock the knob by pulling and rotating it through 90° making sure it does not return to its original position (fig. 39).
- Route the cable with sheath inside the cable raceways, until you reach the motor lock device, avoiding excessively tight sheath curves.
- Take the cable with sheath to detail ② in figure 40, and cut excess sheath.
- Route the cable (fig.40 ref.①) inside detail ②, taking the sheath to its contact point (fig. 40 ref. ⑦).
- Insert the cable in the clamp (Fig.40 ref.③).
- Pull detail ⑧ to its contact point (compressing the springs) and fasten the screw of the clamp ③, thus securing the steel cable.
- Cut the excess portion of the steel cable.
- Make sure that the motor locking device coupling is free of the motor shaft coupling (fig.27 ref A).
- If any adjustments are necessary, use the adjuster of the knob bracket (Fig. 39 ref. ①).
- Release the knob, turning it through 90°, and check if the release functions. Also check if the door opening microswitch (fig.40 ref.④) is activated by pulling the knob.

For electrical connection of the motor locking device, consult the section on the control board in these instructions.

If it is necessary to install the external release device, use the key-operated push-buttons. Fit the release cable on the motor locking device, using the appropriate seat (fig. 40 ref. ⑤).

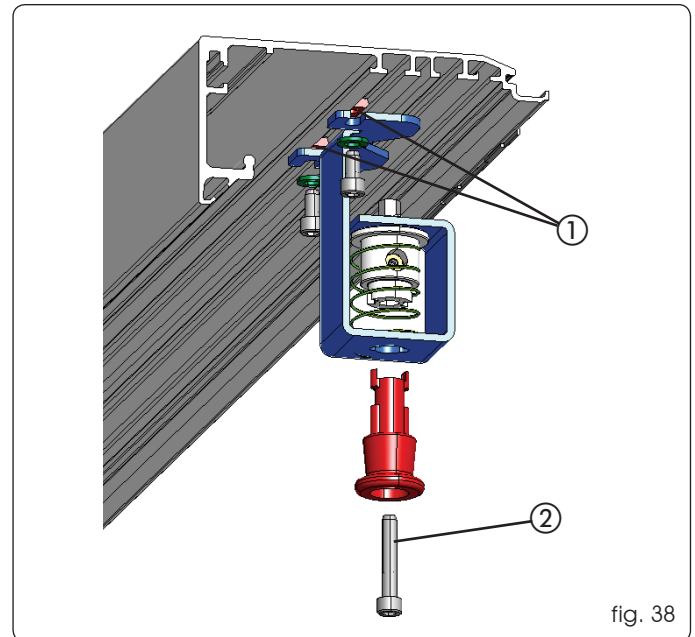

fig. 38

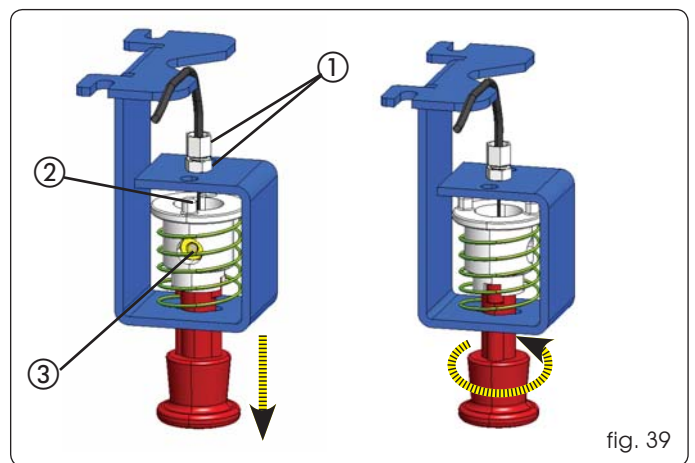

fig. 39

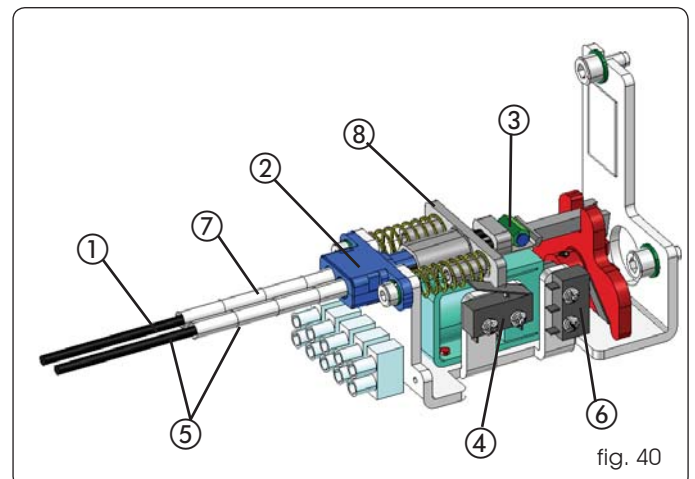

fig. 40

13.3B MICROSWITCH FOR SUPERVISION OF MOTOR LOCKING DEVICE

This accessory makes it possible to verify correct operation of the motor lock and, if it stays locked while open, signals an error via the control board.

Install the supervision microswitch as shown in Fig. 40 ref. ⑥. For electrical connection and programming, refer to the control board/accessories section of these instructions.

14B SUPERVISION SENSOR

The supervision sensor is an accessory (magnetic sensor) to which a relay can be connected via a connector (Fig. 41 ref. ④), in order to have a door closed / door not closed state (e.g. to connect an alarm system).
Sensor installation procedure:

- Screw the magnet on the carriage nearest to the closing contact point, using the threaded hole on the belt fitting (fig.41 ref.①).
- Assemble the sensor to the bracket (fig. 41 ref.②), using the plastic nuts. Inset a threaded plate on the seats of the support profile, and install the bracket, using the screws (fig. 41 ref.③). Check if the sensor is in line with the magnet when the leaf is closed.

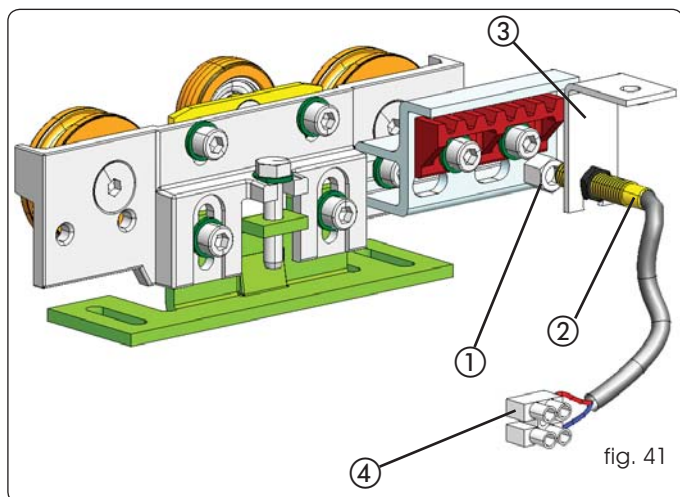

15B INSTALLING THE EMERGENCY BATTERY KIT

- Fit two plates in the support profile as shown in Fig. 42.
- Secure the battery support on the support profile, using the two supplied screws.
- For electrical connection of the battery board and for programming, refer to the control board section of these instructions.

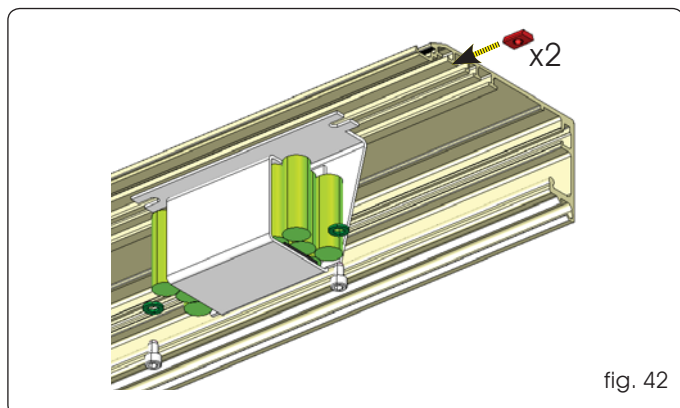

16B INSTALLING THE CLOSING HOUSING

 **Cut the housing profile to the same length as the support profile, except for 2mm to facilitate closing housing blocking with side panels.**

If the motor lock, and relevant release knob are present, drill a hole of at least 18 mm taking care to centre the hole with the release knob.

To facilitate the hole, use the line in fig.43 ref.① as a reference.

 **if the release knob is present, to open the housing, dismantle the knob, unfastening the screw in fig.38 ref. ②**

To install the housing, proceed as described in chapter 11A of the assembled automated system installation.

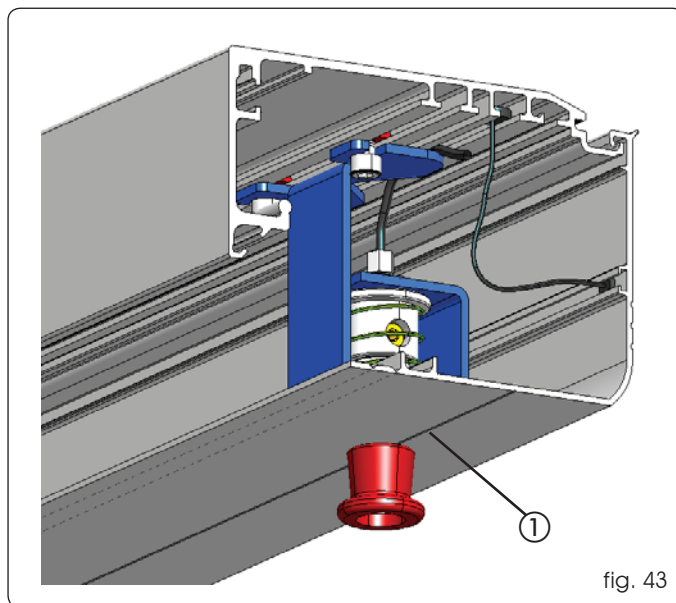

17B START-UP OF THE AUTOMATED SYSTEM

- Manually check correct sliding of the leaves and of all the moving elements.
- Carry out/check the electrical connections on the control board of the power cables coming from the power supply unit, from the motor, and from all accessories, consulting the instructions of the control board.
- Use the raceways - suitably positioned (Fig. 35) - to route the cables inside the support profile, thus preventing them from coming into contact with moving parts.
- Set motor rotation direction according to type of door (refer to the control board instructions).
- Connect the 115V/230V~ power plug to the specific connector of the power supply unit (Fig. 29 ref. ③)

 **Check if the switch in fig. 29 ref. ④ is correctly positioned (230V~/115V~).**

- Check the efficiency of all installed accessories, especially photocells and sensors

E100 - E140 CONTROL BOARD

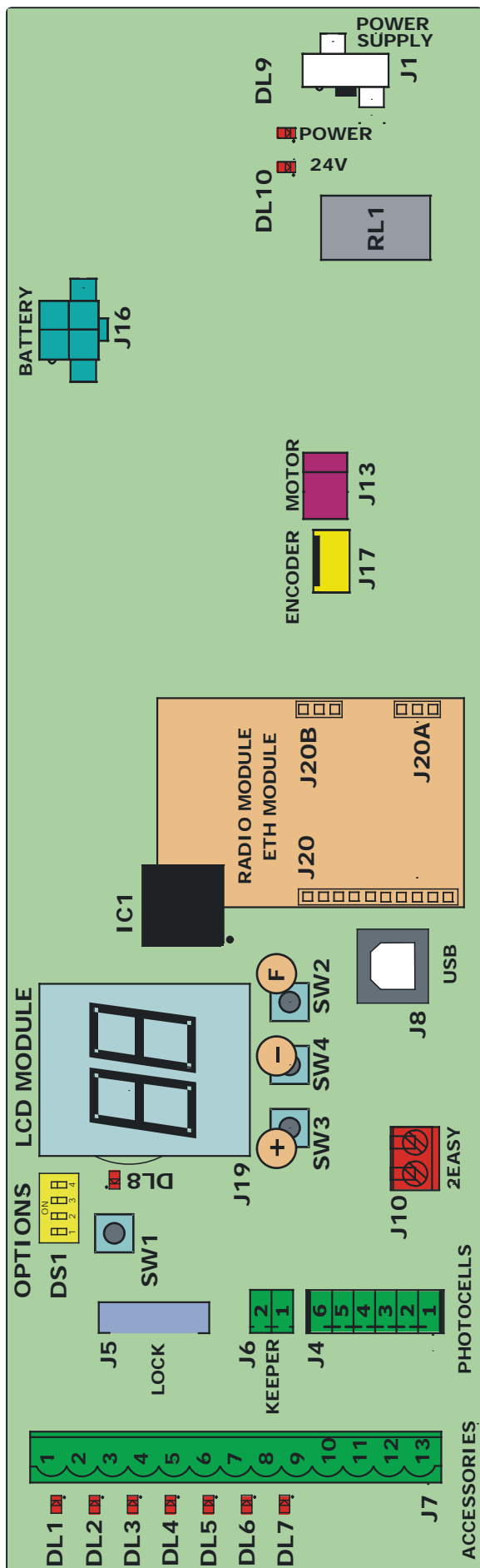

CONNECTOR	MEANING
J1	Main power supply 36V 4A
J4	Button photocells XF A
J5	Motor lock
J6	SD-Keeper - SDK Light
J7	Inputs and power supply for accessories
J8	USB port for connection to PC
J10	BUS - 2 EASY (for future use)
J13	Motor
J16	Emergency battery
J17	Motor encoder
J18-J19	LCD Display
J20-J20A-J20B	Optional modules: - radio module (for E100 e E140) - Eth module (only for E140)

LED	ON	OFF
DL1 (I-DET)	input I-DET closed	input I-DET open
DL2 (E-DET)	input E-DET closed	input E-DET open
DL3 (KEY)	input KEY closed	input Key open
DL4 (EM1)	input EMERG.1 closed	input EMERG.1 open
DL5 (EM2)	input EMERG.2 closed	input EMERG.2 open
DL6 (P1)	input P 1 closed	input P 1 open
DL7 (P2)	input P 2 closed	input P 2 open
DL8 (ERROR)	see table below	
POWER	Mains power supply ON	Mains power supply OFF
24V=	+ 24V= present	+ 24V= absent

LED ERROR STATUS	MEANING
OFF	normal operating condition
ON	microprocessor E140 control board broken
FLASHING	power-on

PUSH-BUTTON	MEANING
SW1	executes automatic SETUP / RESET
SW2	"F" programming push-button
SW3	"+" Programming push-button
SW4	"-" Programming push-buttons

DS1	ON	OFF
Dip n°1	Pair of button photocells No. 1 present	Pair of button photocells No. 1 absent
Dip n°2	Pair of button photocells No. 2 present	Pair of button photocells No. 2 absent
Dip n°3	EMERG2 activates NIGHT function	EMERG2 standard function
Dip n°4	motor rotation direction (see table)	

Connection of safety detector XV1 o XDT1

The XV1 o XDT1 sensor is a monitored opening and closing safety detector, conforming to the EN16005 standard. Below are the connections of 2 sensors on J7 connector automatic door board:

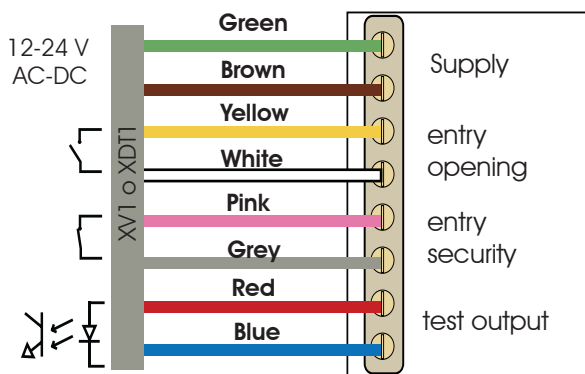

ENGLISH

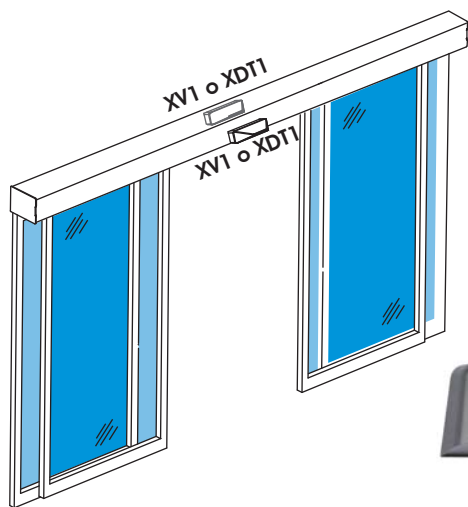

Programming from Display
for 2 XV1 o XDT1 sensors
connected on inputs P1 and P2:

P1=Cc
IF=Y
P2=Cc
ZF=Y

Connection of XV1 o XDT1 and XBFA ON safety detectors

The XV1 o XDT1 sensor is a monitored opening and closing safety detector and the XBFA ON sensor is a monitored opening safety detector, compliant with the EN16005 standard. Below are the connections of 2 sensors on J7 connector automatic door board:

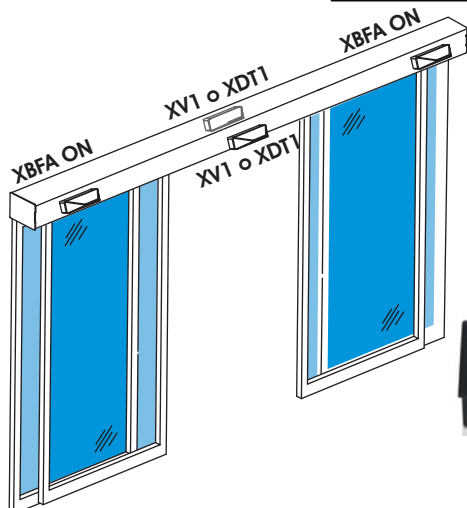
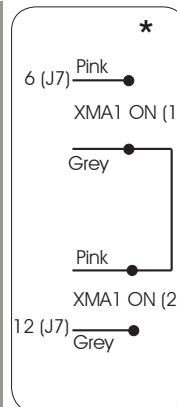
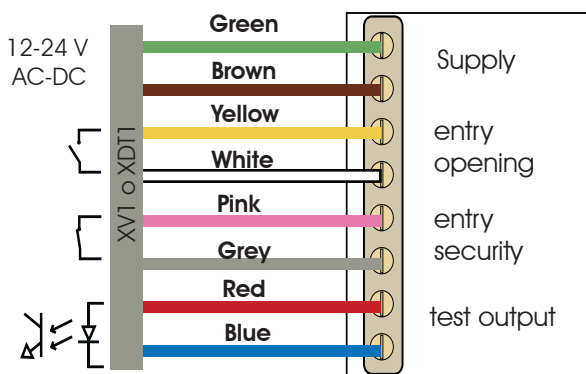

Programming from Display
for 2 XV1 o XDT1 sensors
serially connected on input P1
and 2 XBFA ON sensors in series
on input P2 :

P1=Cc
IF=Y
P2=0c
ZF=Y

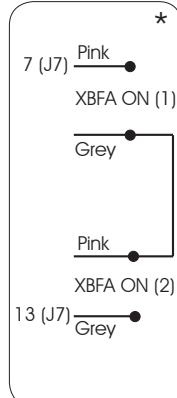

Connection terminal J4

! For extra-European countries where the EN16005 standard is not in force, it is possible to continue using photocells and traditional sensors.
Warning : photocells are not permitted as a safety device in the countries of the European community where the EN16005 standard is in force. Specifically, photocells are considered as auxiliary devices, complementary to safety. Below are the connections on automatic door board:

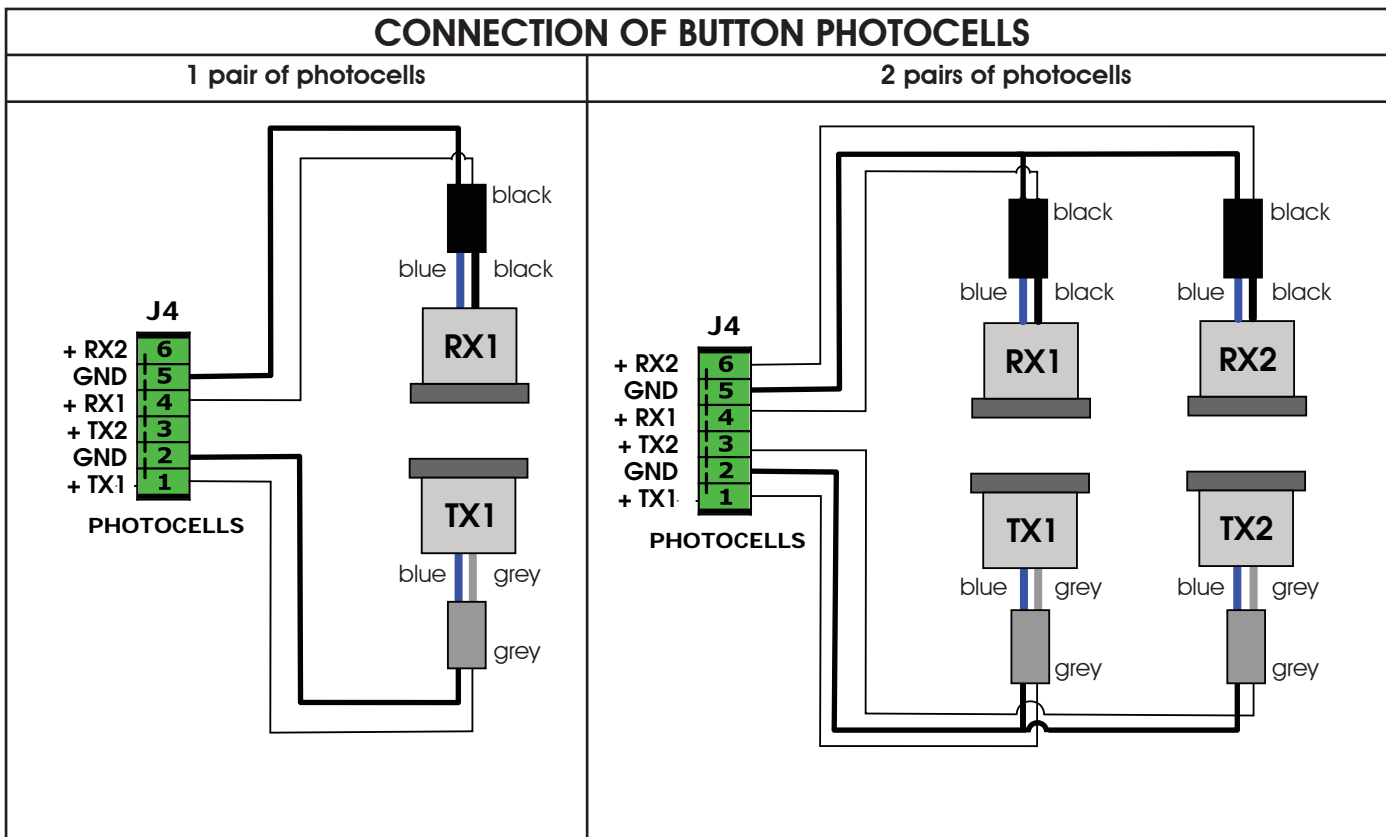

ENGLISH

- If you are not using any pair of photocells, leave the inputs of connector J4 free.
- The button photocells are constantly monitored by the electronic control board of the door. The board controls correct operation of the door at every movement.
- The colours of the button photocell (heads) cables are:
 receiver black/blue
 transmitter grey/blue
- The colours of the button photocells sheaths are:
 receiver black
 transmitter grey

Terminal-board J4

- 1 TX1**
Connection to transmitter of 1st pair of button photocells
- 2 TX GND**
Negative connection for button photocells transmitters
- 3 TX2**
Connection to transmitter of 2nd pair of button photocells.
- 4 RX1**
Connection to receiver of 1st pair of button photocells.
- 5 RX GND**
Negative connection for button photocells receivers
- 6 RX2**
Connection to receiver of 2nd pair of button photocells.

The following configurations are possible if using button photocells: (Ref. **DIP-SWITCH PROGRAMMING**)

- NO PHOTOCELL**
 - Position dip-switches 1 and 2 of DS1 to OFF.
 - Leave the relevant inputs free on J4
- 1 PHOTOCELL**
 - Position dip-switch 1 or 2 to ON in according to input used and other dip-switch to OFF.
 - Leave inputs not used free on J4 .
- 2 PHOTOCELL**
 - Position dip-switches 1 and 2 of DS1 to ON.
 - Connect the photocells as shown in the lay-outs

SETUP

The following parameters are checked and adjusted during the Setup cycle:

- measurement of masses and friction, setting of speeds, plus optimal acceleration and deceleration;
- acquisition of open and closed door positions;
- self-setting of the anti-crushing system at opening/closing according to selected speeds.

During Setup, on the display flashes status 08 until the end of the process if correctly executed.

Any faults are signalled by the display and by the diagnostics via SD-Keeper.

Detection of serious faults (e.g. insufficient or excessive leaf travel, too much friction, motor malfunctions) is signalled by the display and by the diagnostics via SD-Keeper.

To activate a new Setup procedure, press and release the SW1 push-button on the board for more than 5 seconds and then release it; Setup can also be started by a combination of push-buttons on SD-Keeper (see relevant instructions).

The following are the situations in which, if required, the Setup cycle is not executed, and the door stays in shut-down state, generating an alarm signal (ALARM 15 on the display and on SD-Keeper):

- door powered by battery;
- NIGHT operating function selected;
- MANUAL operating function selected;
- an emergency input is active;
- photocells engaged;
- no power supplied to motor.
- external or internal release activated

When the cause has been eliminated, the Setup starts automatically.

RESET

Whenever the automated system is powered, the door executes a Reset cycle during which:

- the door's travel limit positions are sought;
- any alarm signals are reset.

To activate a new Reset procedure, press the SW1 push-button on the board for 1 second; Reset can also be started by a combination of push-buttons on SD-Keeper (see relevant instructions).

If a Reset is commanded while the door is in "Manual" mode, it is executed when this operating function is exited.

In the "Night" operating function, Reset consists of a slow closing movement, whereas it is normally a slow opening movement.

The reset procedure is necessary following the occurrence of certain conditions causing the door to stop operating:

- after an obstacle is detected on 3 successive occasions during closing/opening when the function NO STANDARD OBSTACLE DETECTION (ALARM 8 or ALARM 9) has been activated;
- after a "with memory"-configured emergency command has been activated (see programming instructions), (ALARM 6 or ALARM 7);
- if, when using a motor lock kit, an opening malfunction is detected on the kit.

DESCRIPTION OF TERMINALS

TERMINAL BOARD J7

1 I-DET (NO contact default)

Internal sensor input.
By using SD-Keeper with Display (Accessory), you can modify the polarity of the contact to N.C.

2 E-DET (NO contact default)

External sensor input.
By using SD-Keeper with Display (Accessory), you can modify the polarity of the contact to N.C.

3 KEY (NO contact default)

Key command:
activation causes the door to open, closing it after night pause time.
By using SD-Keeper with Display (Accessory), you can modify the polarity of the contact to N.C.

4 EMERG1 (NO contact default)

Emergency command 1:
in the standard setting, activation causes the door to stop (for as long as it is maintained active, the door stays in stop condition).
By using SD-Keeper with Display (Accessory), you can program the operation of this input in a different way (see programming instructions).

 **the EMERG1 command has priority over EMERG2**

5 EMERG2 (NO contact default)

Emergency command 2:
in the standard setting, activation causes the door to open (for as long as it is maintained active, the door stays open).
By using SD-Keeper with Display (Accessory), you can program the operation of this input in a different way (see programming instructions).

6 PROTECTION 1

Protection 1 input.
Use monitored safety devices that comply with EN1 6005 standard.

7 PROTECTION 2

Protection 2 input.
Use monitored safety devices that comply with EN1 6005 standard.

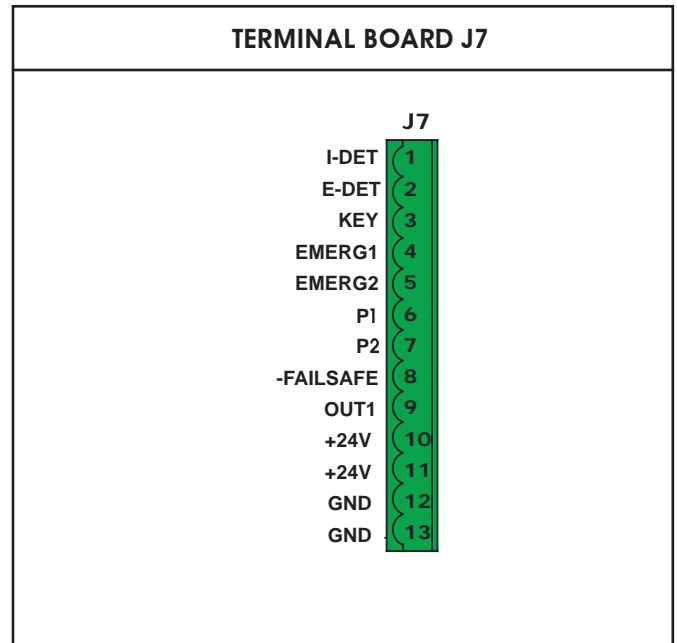

8 -FAIL-SAFE
Negative for powering monitoring sensors.

9 OUT 1 ("gong" default)
Output (negative) of open-collector (max 100mA).
In the standard setting, this output is active when the photocells are shadowed for 1 sec. at intervals of 0.5 sec. until disengagement.
By using SD-Keeper with Display (Accessory), you can program the operation of this output in a different way (see programming instructions).

10-11 +24V=
+24V= for powering accessories
The maximum total load of the accessories connected to inputs "+24V=" must not exceed 1 A.

12-13 GND
Negative for powering accessories and common contact.

ENGLISH

! For extra-European countries where the EN16005 standard is not in force, it is possible to continue using photocells and traditional sensors.
Warning : photocells are not permitted as a safety device in the countries of the European community where the EN16005 standard is in force. Specifically, photocells are considered as auxiliary devices, complementary to safety. Below are the connections on automatic door board:

CONNECTION OF PHOTOCELLS WITH FAIL-SAFE DISABLED

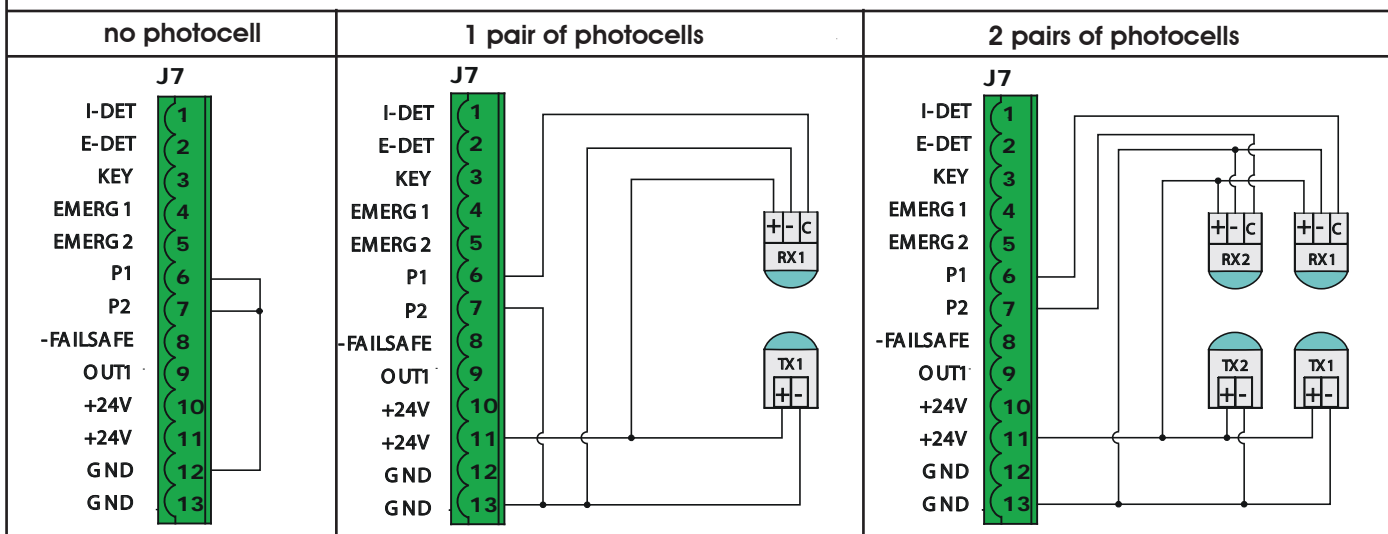

CONNECTION OF PHOTOCELLS WITH FAIL-SAFE ENABLED

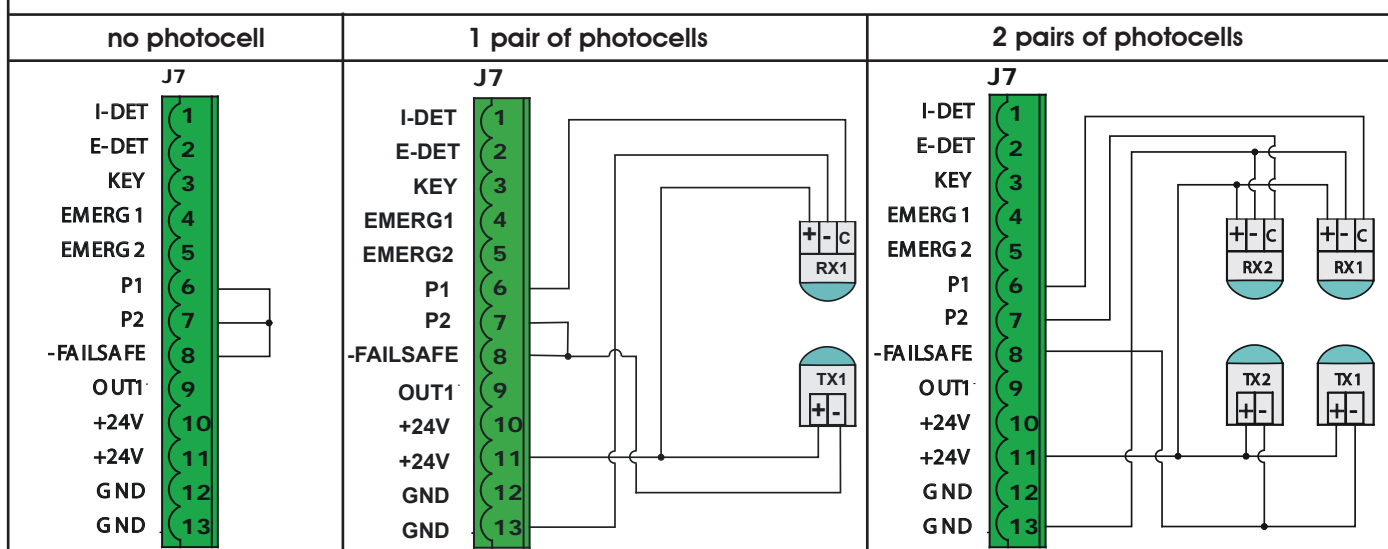

TERMINAL BOARD J7

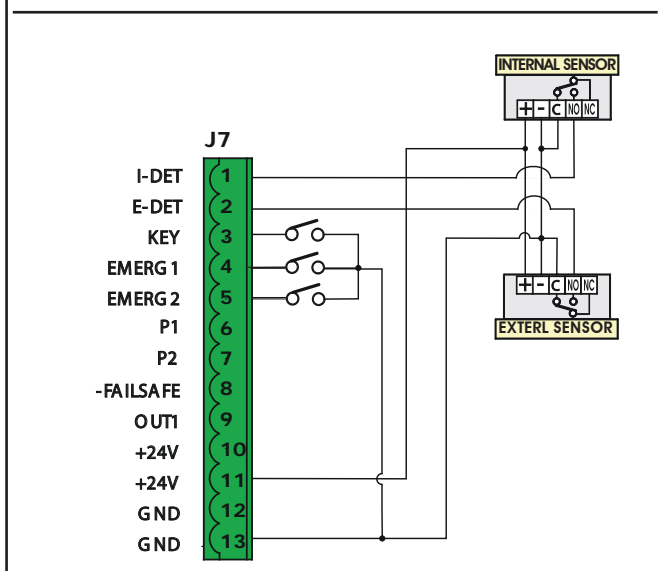

PHOTOCELLS

Two types of photocells can be connected to the door: the traditional ones to be connected to connector J7 (inputs P1 and P2 with N.C. or N.O. contact) and those with a button for connection to connector J4. The following configurations are possible if using traditional photocells:

NO PHOTOCELL

- In the standard configuration, P1 and P2 inputs must be jumper connected to the FAIL-SAFE terminal;
- for the Display, as an alternative, the P1 and P2 inputs can be disabled, thus avoiding the jumpers.

1 PHOTOCELL

- In the standard configuration, the photocell must be connected to the P1 input, while P2 must be jumper connected to the FAIL-SAFE terminal;
- for the Display, as an alternative, one photocell only can be set (connecting it to the P1 input as usual), thus disabling the P2 input and avoiding the jumper .

2 PHOTOCELLS

- connect the photocells to the P1 and P2 inputs.

DIP-SWITCH PROGRAMMING

Set the DS1 dip-switch as follows:

N° DIP-SWITCH	ON	OFF
1	Button photocell 1 active	Button photocell 1 disabled
2	Button photocell 2 active	Button photocell 2 disabled
3	EMERG2 activates NIGHT function	EMERG2 standard function
4	Single leaf door with right opening	Double leaf door or Single leaf door with left opening

 **To find out the closing direction, look at the cross-beam of the automated system from the front and:**
 - for the double leaf, the left leaf is connected to the low branch of the belt;
 - for the single leaf, the leaf is always connected to the low branch of the belt.

 **Activating the dip-switch no. 3 the polarity of the EMERG2 input is forced to NORMAL OPEN and the contact closing activates the NIGHT function independently of the SD-Keeper settings.**

Terminal-board J6

1-2 SD-KEEPER

SD-Keeper connection terminals (cable 2x0.5mm² max 50m).

 **Respect the indicated polarity:**
Terminal 1 = positive Terminal 2 = negative

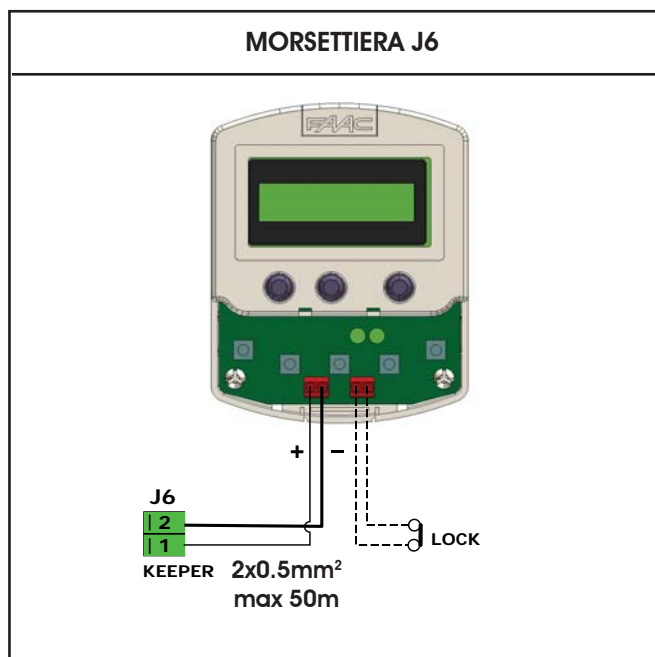

START-UP

The first time the door is powered, the control board automatically executes a setup procedure and loads all the standard configuration settings.

STANDARD CONFIGURATION

The standard configuration is as follows:

- AUTOMATIC "-TOTAL"- "TWO-WAY"; operating function; (maximum OPENING SPEED (level 10));
- CLOSING SPEED level 3;
- EMERG1 emergency input configured as a "no memory" NO contact, i.e. when activated, it causes the movement to stop and the door remains open in stop status for as long as the contact is maintained;
- EMERG2 emergency input configured as a "no memory" NO contact, i.e. when activated, it causes opening at normal speed and the door remains open for as long as the contact is maintained;
- Protection 1 and Protection 2 are configured in Cc
- sensor monitoring enabled
- pause time 2 sec.;
- NIGHT PAUSE time 8 sec.;
- motor lock kit enabled for standard operation (tripped only in NIGHT mode);
- Kit for supervising motor lock is not enabled;
- BATTERY KIT not enabled;
- OUT1 output with GONG function;
- partial opening set at 50%;
- Low DECELERATION SPEED;
- Standard OBSTACLE DETECTION: if an obstacle is recognised at opening or closing, the door reverses and continuously attempts to move until the obstacle is removed, without generating an alarm signal;
- two sensors with NO contact are provided (one internal, the other external);
- NO type KEY contact;
- INTERLOCK function not activated;
- TIMER not activated.

SPEED CHANGES

There are 10 speed adjustment levels for opening and closing. Level 10 refers to the maximum speed permitted by door weight, whereas level 1 refers to the corresponding minimum speed. The OPENING and CLOSING speeds can be adjusted directly on the board (entering programming).

BEHAVIOUR UNDER DIFFERENT OPERATING FUNCTIONS

ENGLISH

OPERATING FUNCTION	DOOR STATUS	INTERNAL SENSOR (I-DET)	EXTERNAL SENSOR (E-DET)	KEY	EMERGENCY OPENING (EMERG 2) (1)	EMERGENCY CLOSING (1)
MANUAL	IN ANY POSITION	no effect	no effect	no effect	no effect	no effect
TOTALLY OPEN	OPEN	no effect	no effect	no effect	no effect	immediate closing
TOTAL AUTOMATIC TWO-WAY	OPEN	restarts pause time count	restarts pause time count	starts night pause time count	starts pause time count	immediate closing
	CLOSED	total opening and re-closing after pause time	total opening and re-closing after pause time	total opening and re-closing after night pause time	total opening	no effect
PARTIAL AUTOMATIC TWO-WAY	PARTIALLY OPEN	restarts pause time count	restarts pause time count	starts night pause time count	total opening	immediate closing
	CLOSED	partial opening and re-closing after pause time	partial opening and re-closing after pause time	partial opening and re-closing after night pause time	total opening	no effect
TOTAL AUTOMATIC ONE WAY	OPEN	restarts pause time count	no effect	starts night pause time count	starts pause time count	immediate closing
	CLOSED	total opening and re-closing after pause time	no effect	total opening and re-closing after night pause time	total opening	no effect
PARTIAL AUTOMATIC ONE WAY	PARTIALLY OPEN	restarts pause time count	no effect	starts night pause time count	total opening	immediate closing
	CLOSED	partial opening and re-closing after pause time	no effect	partial opening and re-closing after night pause time	total opening	no effect
TOTAL NIGHT	CLOSED	no effect	no effect	total opening and re-closing after night pause time	total opening	no effect
PARTIAL NIGHT	CLOSED	no effect	no effect	partial opening and re-closing after night pause time	total opening	no effect

- (1) Emerg1 and Emerg 2 inputs can be programmed with SD- Keeper+Display to obtain:
- emergency opening;
 - emergency closing;
 - stop.

- Furthermore, command activation can be programmed:
- with no memory (when the command is de-activated, the door resumes normal operation);
 - with memory (when the command is de-activated, a Reset is necessary to restore normal operation).

This is the default configuration:
 Emerg1 ---> Stop/no memory
 A pulse (function not shown in the table) causes immediate stop followed by slow re-closing after pause time (night pause time if the Night operating function was set).
 Emerg2 ---> Emergency opening/no memory:
 A pulse causes opening followed by re-closing after pause time.
 Emergency commands have priority over all others.

DESCRIPTION AND USE OF ENERGY SAVING



1) Function description:

An automated system that can operate in "Energy Saving" mode. Thanks to this operating mode the system is able to recognize the pedestrian direction (approaching, leaving or side transit) and, as a consequence, to limit false opening operations and reduce opening/closing times.

2) Compulsory use mode:

The "Energy Saving" function can only be enabled together with the XV1 o XDT1 double-technology presence and pulse detectors.

⚠ Important : A detector only is not sufficient to activate the " Energy Saving " function.
The described function can only be activated with XV1 o XDT1 internal and external sensor.
The passage width VP max. for an XV1 o XDT1 sensor in order to use the Energy Saving function is 2mt.
For a passage width VP over 2mt., use 2 XV1 o XDT1 side-by-side sensors with a different frequency and configured as indicated in XV1 o XDT1 manual

3) Use instructions

To guarantee maximum safety the use instructions of XV1 o XDT1 sensor must be carefully observed.

For any depth adjustment operations, use the **Spotfinder detector**. This accessory device enables you to detect the position of the infrared field curtains for spot so exactly that you can adjust both the command-pulse area and the safety area on the passage width of our XV1 o XDT1 active infrared sensors in a precise manner. For any further explanation, consult the use manual of the XV1 o XDT1 sensor.

4) " Energy Saving " function activation mode.

To activate the " Energy Saving " function you need to reach parameter PA on the board display and set it to NO or use the SD-KEEPER with DISPLAY and, when in programming mode, select: Menu 2 SETUP ----> 2.2 Pause time ---->Off

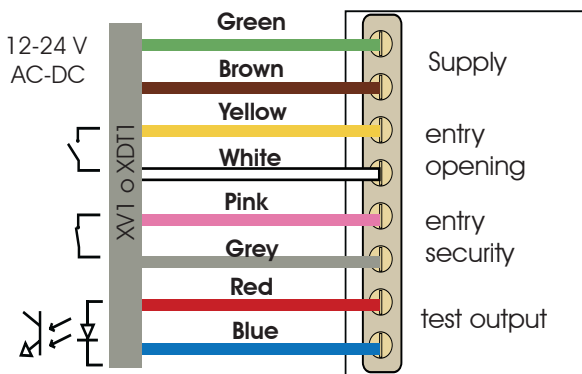

ENGLISH

The EN16005 standard in force in European Community countries provides for the use of monitored devices or machine operation in **LOW ENERGY** mode.

The **LOW ENERGY** mode provides for a limitation of the maximum kinetic energy of the leaf and forces.

Table 1 provides an indication of the maximum speed settable on the electronic board based on the mass of the leaf.

In any case it is necessary to verify that the set speed value ensures compliance with EN16005.

For more details, please refer to standard EN16005.

Table 1 below shows the mass of the leaf and the speed to be set with reference to the mass.

The setting of the maximum force on opening and closing on the board must not be higher than 5.

 **WARNING:**

Operation at low energy must not be used when a large proportion of users are elderly, infirm, disabled or children. In this case contact of the door with the user is UNACCEPTABLE:

In these cases special monitored sensors must be used or suitable mechanical protection devices or sensors (for opening only)

Mass (Kg)	Setting Speed
10	9
20	8
30	7
40	6
50	6
60	5
70	5
80	5
90	4
100	4
110	4
120	4
130	4
140	4
150	4
160	3
170	3
180	3
190	3
200	3
210	3
220	3
230	3
240	3

TAB.1

Table 2 below indicates the minimum stroke time per leaf referred to door mass and leaf stroke as per standard EN16005 :

90% of the stroke leaf D [m]	Leaf Mass															
	10	20	30	40	50	60	70	80	90	100	110	120	130	140	150	
	Minimum time stroke															
0,7	1,3	1,8	2,1	2,5	2,7	3,0	3,2	3,5	3,7	3,9	4,0	4,2	4,4	4,6	4,7	
0,8	1,4	2,0	2,4	2,8	3,1	3,4	3,7	3,9	4,2	4,4	4,6	4,8	5,0	5,2	5,4	
0,9	1,6	2,2	2,7	3,1	3,5	3,8	4,1	4,4	4,7	4,9	5,2	5,4	5,6	5,8	6,0	
1,0	1,8	2,5	3,0	3,5	3,9	4,3	4,6	4,9	5,2	5,5	5,8	6,0	6,3	6,5	6,7	
1,1	1,9	2,7	3,3	3,8	4,3	4,7	5,1	5,4	5,7	6,0	6,3	6,6	6,9	7,1	7,4	
1,2	2,1	3,0	3,6	4,2	4,7	5,1	5,5	5,9	6,2	6,6	6,9	7,2	7,5	7,8	8,0	
1,3	2,3	3,2	3,9	4,5	5	5,5	6,0	6,4	6,8	7,1	7,5	7,8	8,1	8,4	8,7	
1,4	2,5	3,5	4,2	4,9	5,4	5,9	6,4	6,9	7,3	7,7	8,0	8,4	8,7	9,1	9,4	
1,5	2,6	3,7	4,5	5,2	5,8	6,4	6,9	7,3	7,8	8,2	8,6	9,0	9,4	9,7	10	

TAB.2

Values higher than those indicated in the table are obtained by interpolation as indicated by the EN16005 standard.

PROGRAMMING THE E100 - E140 BOARD rev.4.5		
Display	Function	Default
Pn	Disactivation & Pause time Parameter to disactivate the pause time and set the pause time in the "automatic" operating mode. Adjustable from NO, to disactivate the pause time, it can be set from 0 to 30 sec. in one-second steps. Adjustment: NO,0,1,3,4,5,.....30	2
Pn	Night Pause Time Sets pause time in the night operating mode. Can be adjusted from 2 to 58 sec. in two-second steps. Next, the viewing changes in minutes and tenths of a second (separated by a dot) and time is adjusted in 10-second steps up to the maximum value of 4.0 minutes. E.g.: if the display shows 2.5, the pause time will be 2 min and 50 sec.	8
Cs	Closing speed Sets the speed level of the door during closing. Adjustment: from 1 to 10	3
Os	Opening speed Sets the speed level of the door during opening. Adjustment: from 1 to 10	10
P1 (*)	Protection 1 no protection not enabled Cc closing protection, contact NC Co closing protection, contact NO Oc opening protection contact NC Oo opening protection, contact NO	Cc
IF	Failsafe 1 no sensor monitoring not enabled y sensor monitoring enabled	y
P2	Protection 2 no protection not enabled Cc closing protection, contact NC Co closing protection, contact NO Oc opening protection contact NC Oo opening protection, contact NO	Cc
2F	Failsafe 2 no sensor monitoring not enabled y sensor monitoring enabled	y
Ot (**)	Opening protection Sets operation of the opening protection 1 when the safety device is engaged on opening the leaf stops. 2 when the safety device is engaged on leaf opening, the opening motion continues at low speed.	1
dr	Deceleration ramp Sets the ramp level while slowing: 0 LOW 1 medium low 2 medium 3 medium high 4 High	2
Ar	Acceleration ramp Sets the ramp level while starting: 0 LOW speed 1 MEDIUM speed 2 HIGH speed	1

Important :
With pause time "NO" you can activate the "Energy Saving" function
Before using this function, refer to chapter "Description and use of Energy Saving".

WARNING :
TO SET PARAMETERS P1, IF, P2, 2F USE THE DISPLAY ONLY.
DO NOT SET PARAMETERS FROM SD-KEEPER .

Some of the main functions of the automatic door can be programmed directly from the control board. To access PROGRAMMING of the board, use push-button F:

- if you press it (and hold it down), the display shows the name of the first function.
- if you release the push-button, the display shows the value of the function, which can be changed with keys + and -.
- if you press F again (and hold it down), the display shows the name of the next function, etc.
- when you reach the last function, press the F push-button to exit programming, and the display resumes showing the inputs status.

The following table indicates the sequence of functions accessible in PROGRAMMING::

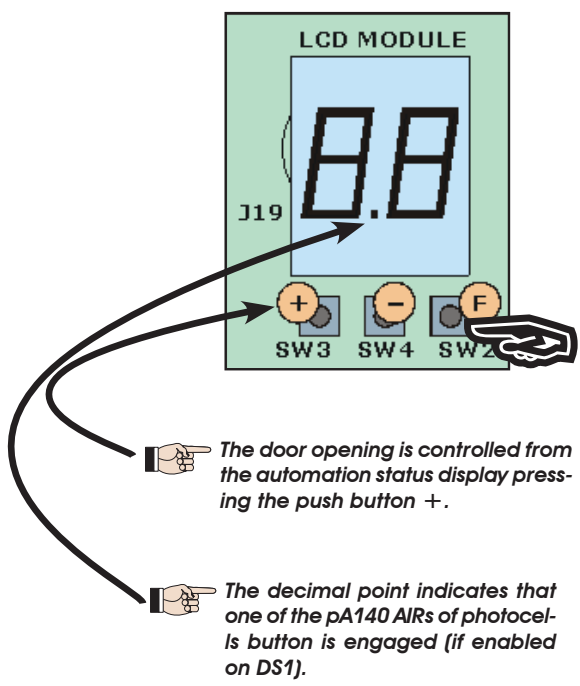

When an alarm is in progress, the display alternately shows AL, followed by the number of the alarm in progress.

To RESET, press the SW1 push-button for 1 sec. The software of the control board is shown.

(*) With parameter P1 at NO values 1F, P2 and 2F are not displayed..
() Parameter Ot is only displayed with P1 and/or P2 or Oc or Oo .**

PROGRAMMING THE E100 - E140 BOARD rev.4.5																						
Display	Function	Default																				
OF	<p>Opening force Sets the force of the door during opening in the event of an obstacle for the time tF.</p> <p>Adjustment: from 1 to 10</p>	7																				
CF	<p>Closing force Sets the force of the door during closing in the event of an obstacle for the time tF.</p> <p>Adjustment: from 1 to 10</p>	7																				
tF	<p>Push time OF and CF Sets the time during which the door during opening and closing remains on the obstacle with a push OF and CF.</p> <p>Can be adjusted from 0.0 to 3.0 sec. in 0.1second steps.</p>	1																				
bA	<p>Battery Kit It enables you to set the battery kit functions. For the function descriptions, refer to the dedicated paragraph:</p> <p>0 battery kit NOT ENABLED 1 battery kit ENABLED standard operation – last manoeuvre opening 2 battery kit ENABLED standard operation – last manoeuvre closing 3 battery kit ENABLED operation NO standard – last manoeuvre opening 4 battery kit ENABLED operation NO standard – last manoeuvre closing</p>	0																				
EL	<p>Motor lock kit Enables to set the motor lock functions.</p> <p>0 Off Motor lock not installed. 1 Night The motor lock locks the leaves only in the "Night" operating mode 2 One way + Night The motor lock locks the leaves in the "Night" and "one way" operating modes. 3 Always The motor lock locks the leaves whenever the leaves close, irrespective of the set operating function.</p>	1																				
SU	<p>Surveillance Enables to select the presence of the motor lock supervision.</p> <p>no Motor lock surveillance device not installed. Y Motor lock surveillance device installed.</p>	no																				
nd	<p>Night mode internal sensor deactivation delay</p> <p>Parameter for delaying deactivation of the Night mode internal sensor.</p> <p>Adjustable from 0 to 60 sec. in 1-second steps.</p>	0																				
St	<p>Status of the automated system Exit from programming, storage of the settings and return to the automated system status display.</p> <table border="0"> <tr> <td>00</td> <td>Closed</td> <td>05</td> <td>Closes</td> </tr> <tr> <td>01</td> <td>Opening</td> <td>06</td> <td>Emergency</td> </tr> <tr> <td>02</td> <td>Open</td> <td>07</td> <td>Manual mode</td> </tr> <tr> <td>03</td> <td>Pause</td> <td>08</td> <td>Setup (flashing)</td> </tr> <tr> <td>04</td> <td>Night pause</td> <td></td> <td></td> </tr> </table>	00	Closed	05	Closes	01	Opening	06	Emergency	02	Open	07	Manual mode	03	Pause	08	Setup (flashing)	04	Night pause			
00	Closed	05	Closes																			
01	Opening	06	Emergency																			
02	Open	07	Manual mode																			
03	Pause	08	Setup (flashing)																			
04	Night pause																					



Important :

After having fitted the battery kit, you need to enable it from the board to make it operating: to this end use push-buttons F +/- on parameter bA. For any additional explanations, please refer to chapter **3 Battery**.

SD-KEEPER PROGRAMMING UNIT

The SD-Keeper is used for selecting operational functions, and for controlling and programming sliding automatic doors. It is divided into two parts: a fixed part used for selecting the operating functions by means of push-buttons and relevant signalling LEDs (fig. 61 ref. A), and a pull-out part with LCD display to access complete programming (fig. 61 ref. B). The SD-Keeper display can be used as a temporary programming unit: after all programming and adjustments have been carried out, it can be fully removed because the settings remain stored on the control board. When the display is removed, a cover is provided (fig. 61 ref. C).

SD-Keeper can be disabled by a combination of keys (see the special LOCK function) or by internally fitting a jumper by means of a switch (fig.62 ref. LOCK).

FITTING

Refer to fig. 62 for an exploded view of fitting. Let cable route through point A or B according to the cable position needs.

CONNECTIONS

Connect SD-Keeper to the control board with the following cable: 2x0.5mm² max 50m (fig. 62).

If a jumper is closed between two terminals as shown in fig. 62 (LOCK), all keys on the programmer are disabled.

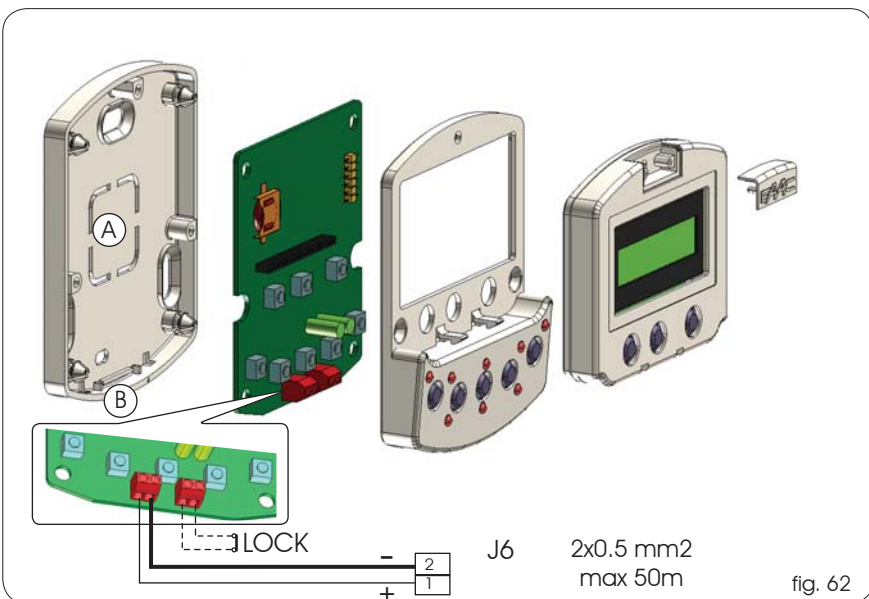
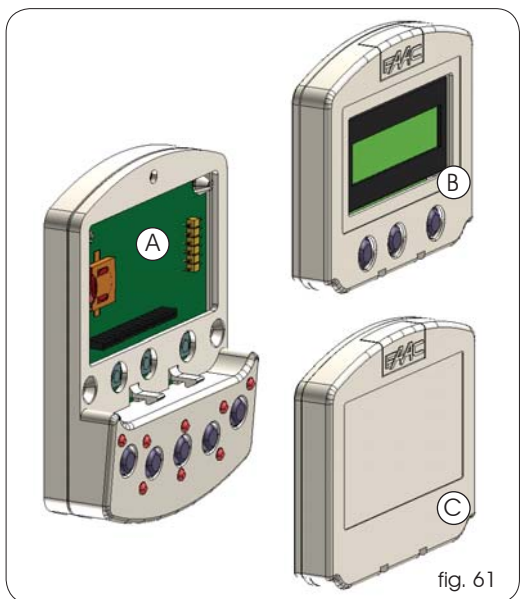

DIAGNOSTICS

SD-Keeper (also without display) has a diagnostic function which, in case of an alarm, interrupts normal display of the function every 2 seconds in order to show the fault status for 1 second by a combination of flashing LEDs. Consult fig.63 and table 1 to identify the type of alarm by interpreting the flashing LEDs. If there are several simultaneous faults, the first to be detected is shown.

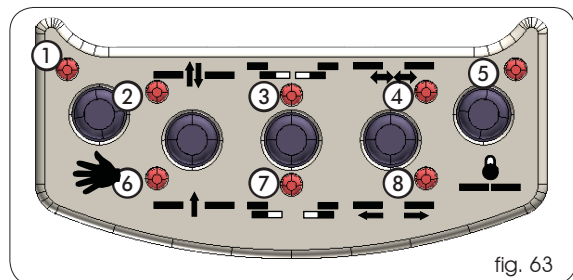

Tab.1 DIAGNOSTICS		Led ● =on ○=off							
DESCRIPTION	MEANING	①	②	③	④	⑤	⑥	⑦	⑧
ENERGY SAV.	Operating on low battery consumption	○	●	○	○	○	○	○	○
2 BAT. OPERATION	Door operating on battery	○	○	●	○	○	○	○	○
3 FORCED OPEN	Door forced opening in progress	○	○	●	○	○	○	○	○
4 FLAT BATTERY	Battery discharged: emergency movement not guaranteed	○	○	○	●	○	○	○	○
6 EMERG 2 ON	Emergency 2 input active	○	○	●	●	○	○	○	○
7 EMERG 1 ON	Emergency 1 input active	○	○	●	●	○	○	●	○
8 OBST. IN OPEN.	Opening obstacle detected 3 successive times; Reset necessary to restore operation	○	○	○	○	○	○	○	●
9 OBST. IN CLOS.	Closing obstacle detected 3 successive times; Reset necessary to restore operation	○	○	○	○	○	○	●	●
10	Motor lock locked in closed position	○	○	●	○	○	○	○	●
11	Motor lock locked in open position (with surveillance kit only)	○	○	●	○	○	○	●	●
12	Incorrect power supply to motor	○	○	○	●	○	○	○	●
13	Sensor monitoring test 2 failed on input P2	○	○	○	●	○	○	○	●
14	Sensor monitoring test 1 failed on input P1	○	○	●	●	○	○	○	●
15	Setup not possible	○	○	●	●	○	○	●	●
22	Initialisation process not possible on motor: too much friction or leaf too heavy	○	●	●	●	○	○	○	○
23	Accessory power supply +24 V dc faulty (probable short circuit)	○	●	●	●	○	○	●	○
24	Motor failure	○	●	○	○	○	○	○	●
25	Control board faulty	○	●	○	○	○	○	●	●

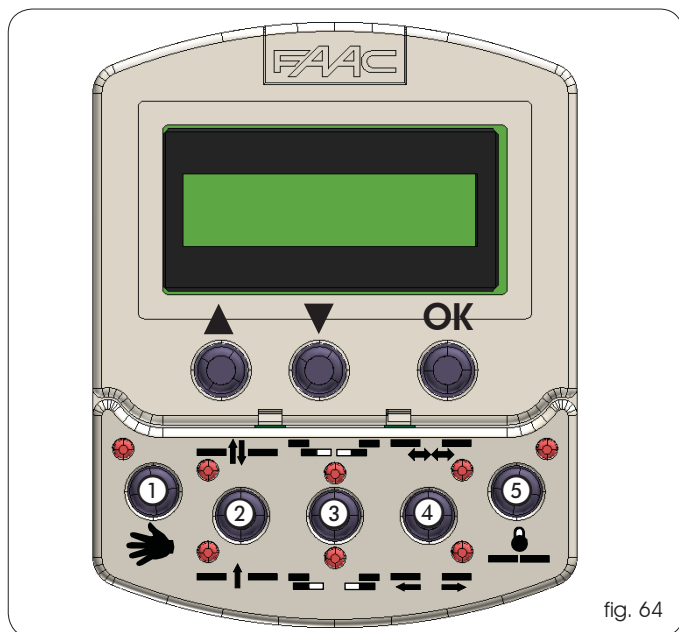

fig. 64

①		MANUAL
②		TWO-WAY
		ONE WAY
③		PARTIAL OPENING
		TOTAL OPENING
④		AUTOMATIC
		DOOR OPEN
⑤		NIGHT

OPERATING FUNCTIONS

Selection is performed by pressing the keys on the fixed part of the programmer - the function is indicated by the relevant LED lighting up.

when the "Night" or "Manual" modes have been set, the relevant selection keys must be pressed to exit the modes.

Manual

The sliding leaves are free and can be activated manually.

Two-way

Pedestrian transit is possible in both directions; the inside and outside radars are enabled.

One way

Pedestrian transit is possible in one direction only; the external radar is disabled.

Partial opening

The door opens only partially (standard: 50%)
Partial opening can be adjusted in range from 10% to 90% of total.

Total opening

The door opens completely.

Automatic

The door opens (partially or totally) and then re-closes after the set pause time (standard: 2 sec.).
Adjusting range of pause time: 0 to 30 sec.

Door open

The door opens and stays open.

Night

The door closes and the motor lock (if present) is activated. The internal and external radars are disabled.
The Key command causes the door to open and re-close after night pause time elapses (standard: 8 sec).
Adjusting range of night pause time : 0 to 240 sec.
To obtain partial opening in this mode, before selecting the "Night" function, activate the "Partial Opening" function.

SPECIAL FUNCTIONS

Setup

Setup is the door initialisation function during which parameters are self-learned.

To activate, simultaneously press keys ① and ⑤ for 5 sec.

Reset

Reset is the function for restoring normal operating conditions after some types of alarm have been signalled.

To activate, simultaneously press keys ② and ③ .

Lock

When active, the Lock function disables SD-Keeper.

To activate (and de-activate), simultaneously press keys ③ and ④ for 5 sec.

BATTERY INSERTION/CHANGE

To keep the clock inside SD-Keeper active even in the event of a power cut, a 3V model CR1216 lithium battery is provided. Insert or replace the battery in the compartment on the printed circuit (fig.65) respecting the indicated polarity.

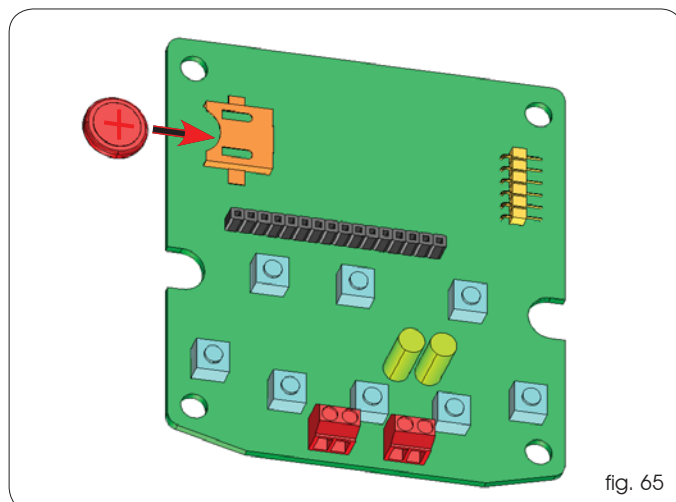
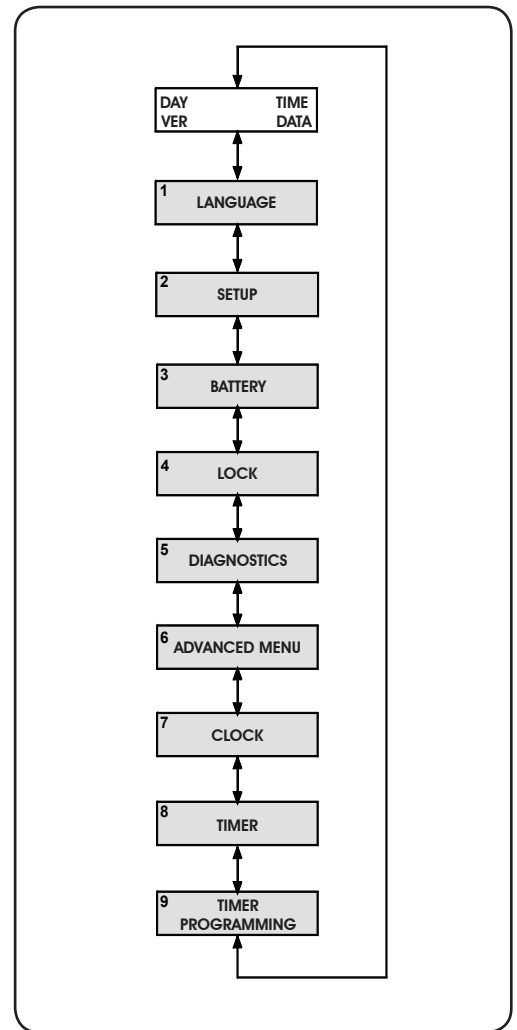
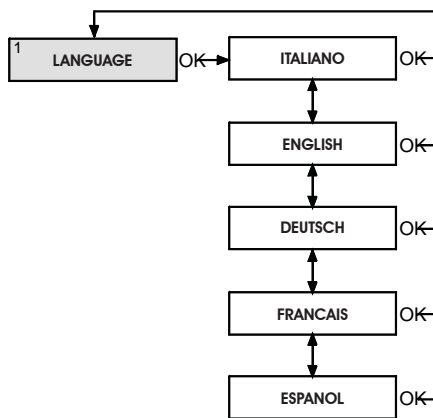
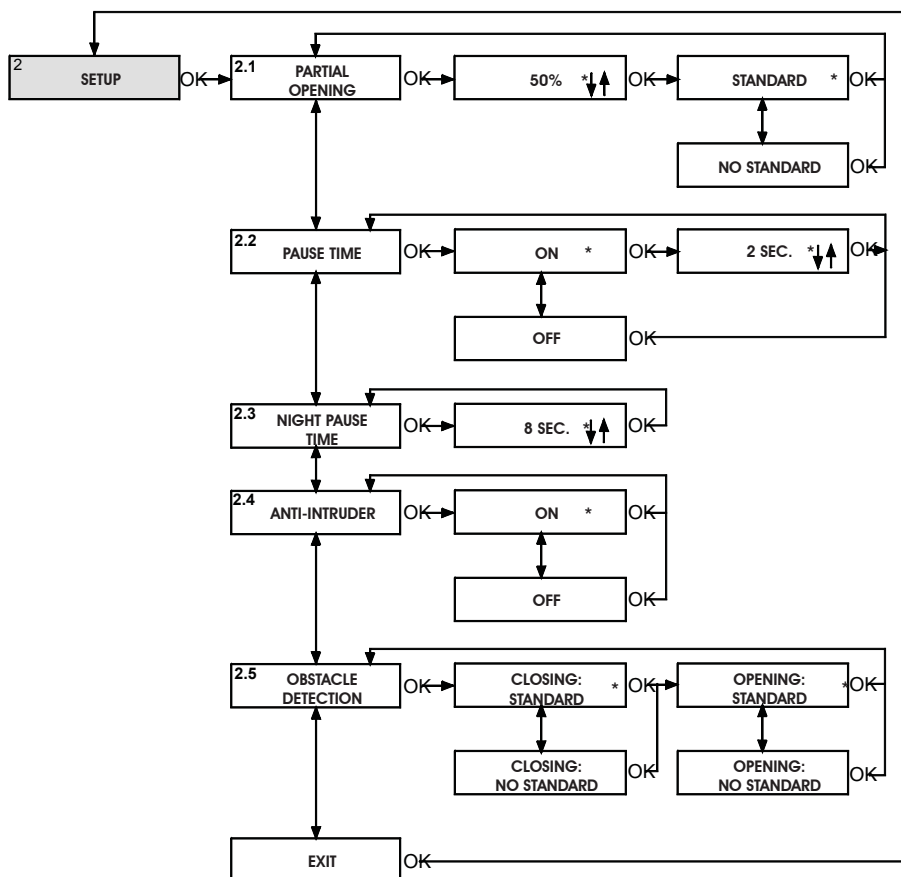

fig. 65

To access programming while the standard view is shown on the display, press any of keys ▲ or ▼ .
 Programming is subdivided into main menus (see box) split into subjects.
 After selecting the menu with keys ▲ or ▼, to access it press OK.
 Each menu is, in turn, subdivided into sub-menus at different parameter setting levels.
 Use keys ▲ or ▼ to select (sub-menu or parameter) and confirm with the OK key.
 An asterisk on the display indicates the currently active setting.
 To exit programming, select the "exit" function at each level. Otherwise, after about 2 minutes, the display automatically returns to standard view.



ENGLISH



Important :
 With pause time "OFF" you can activate the "Energy Saving" function. Before using this function, consult the chapter "Description and use of Energy Saving".

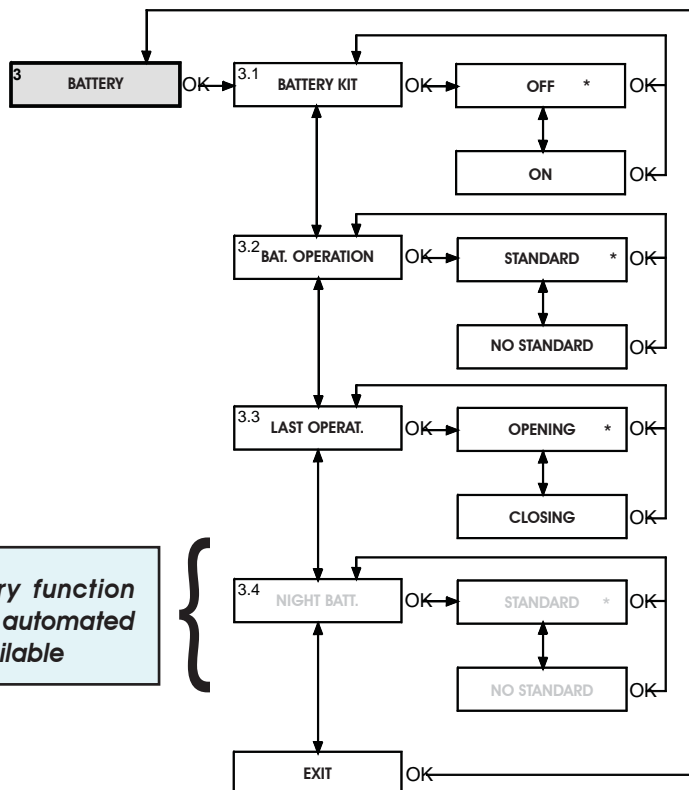

 **Important :**
After having fitted the battery kit, you need to enable it using the SD Keeper programming unit in order to make it operating.

The night battery function in the A140 AIR automated system is not available

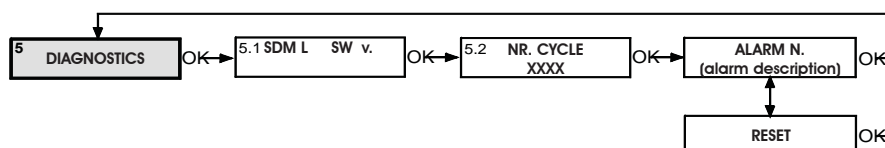
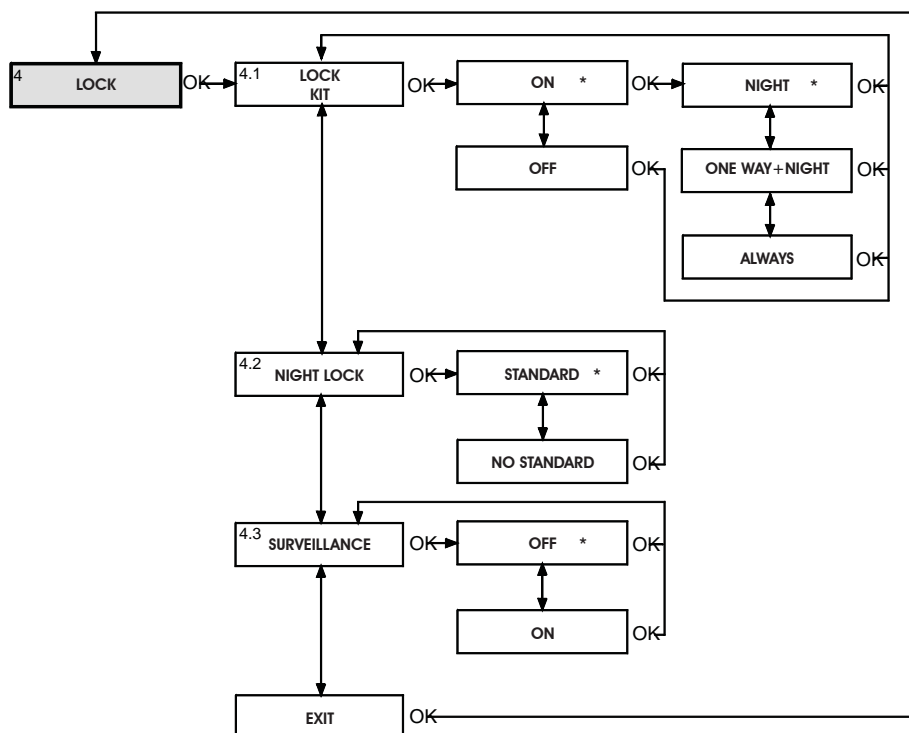

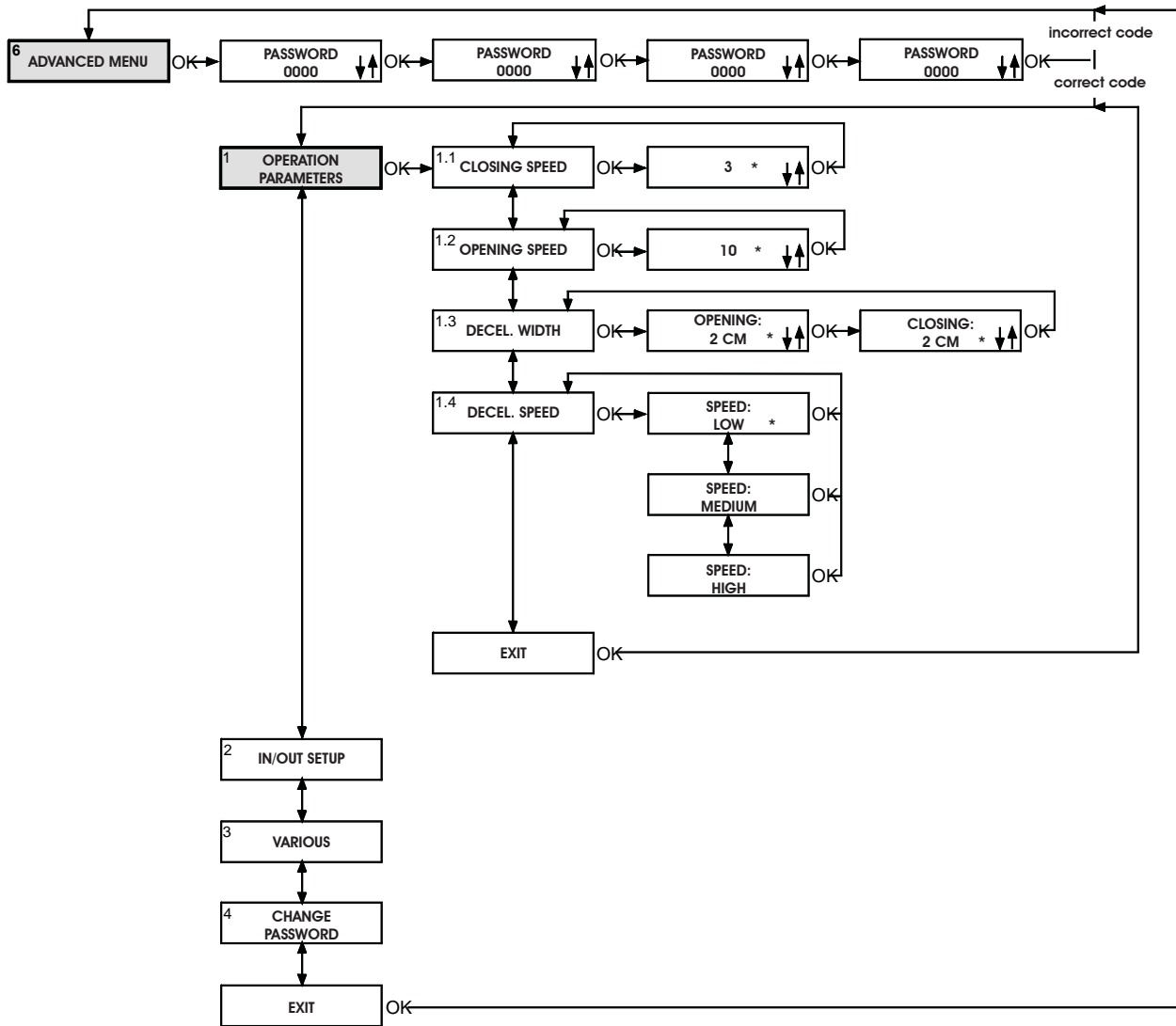

ENGLISH

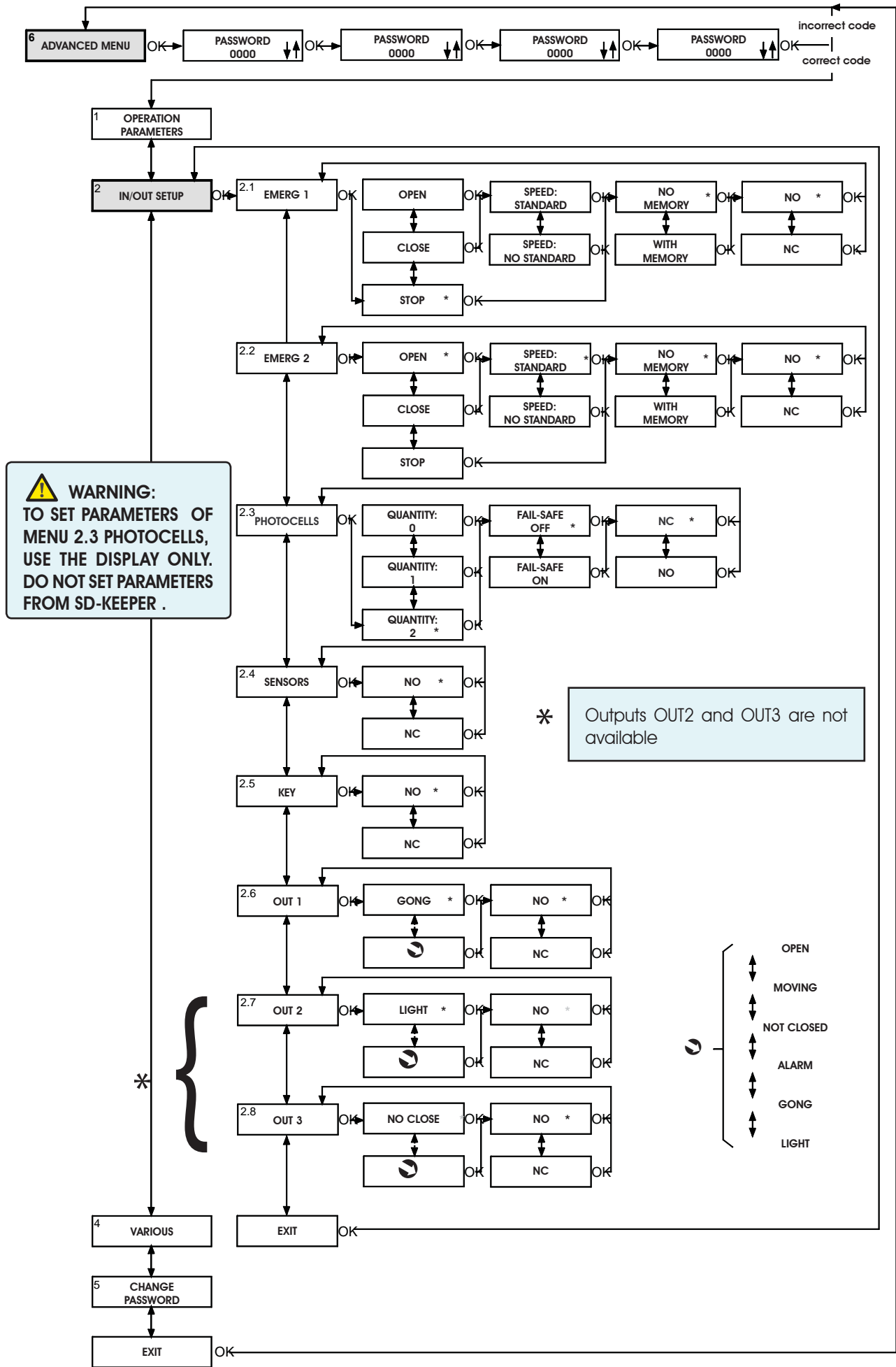

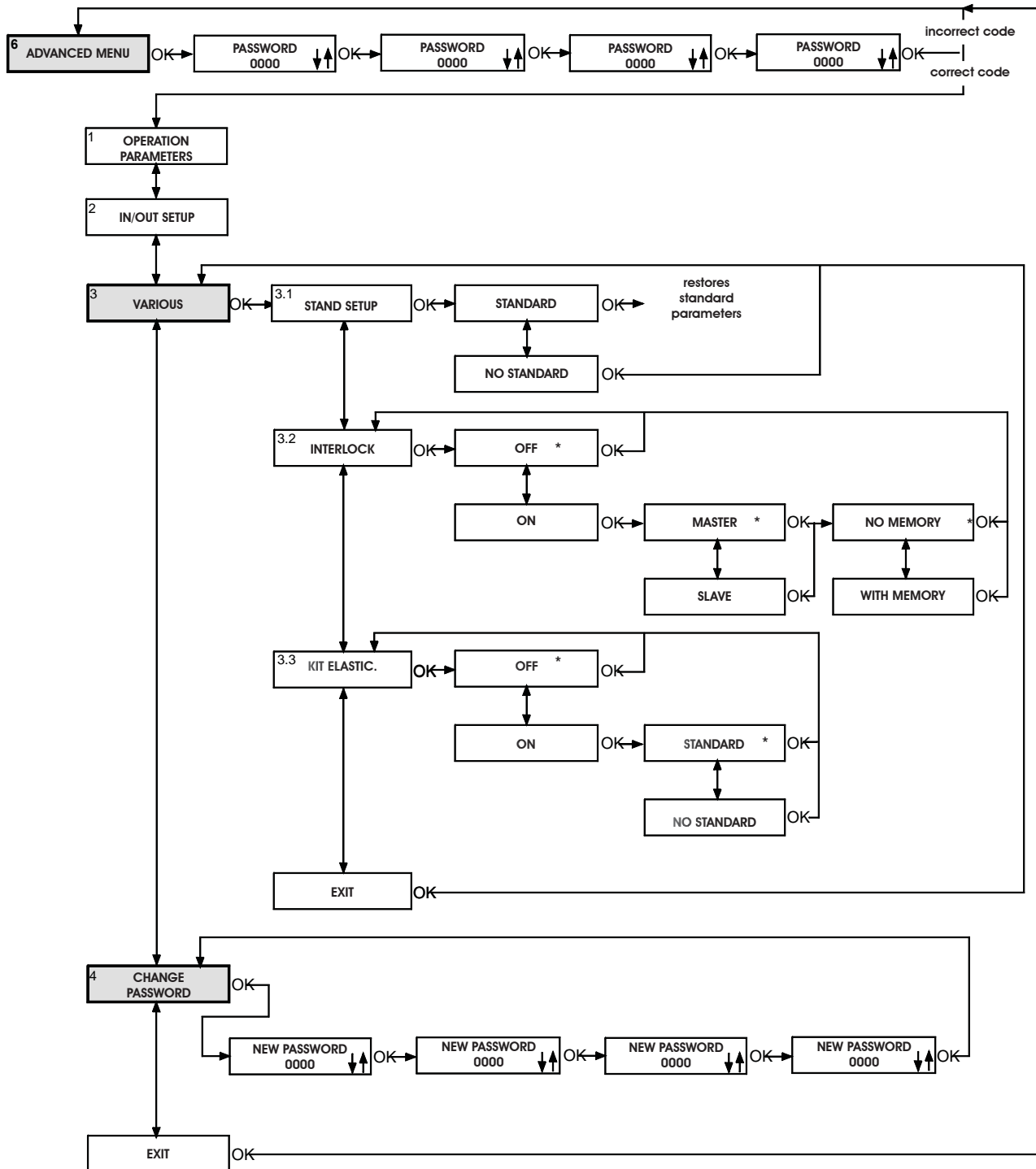

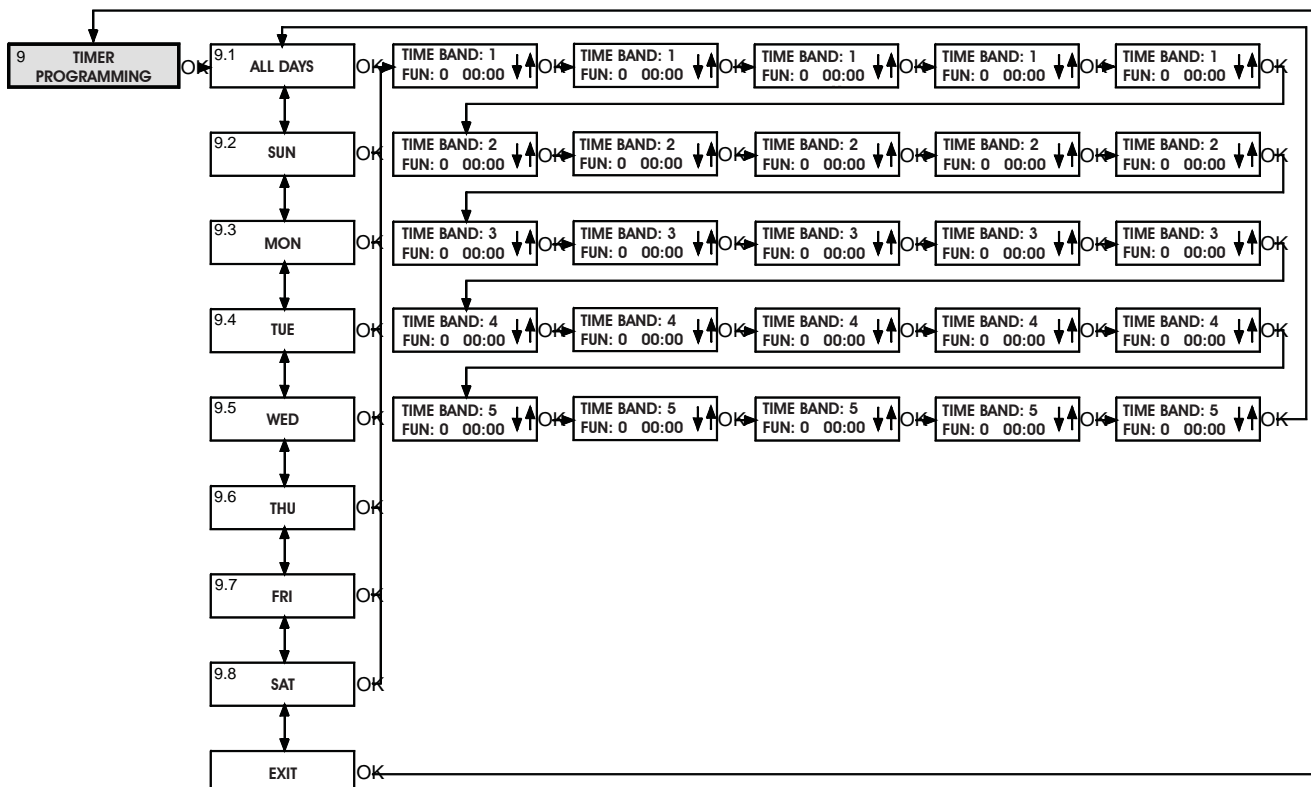
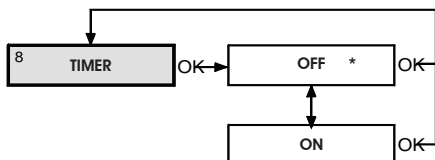
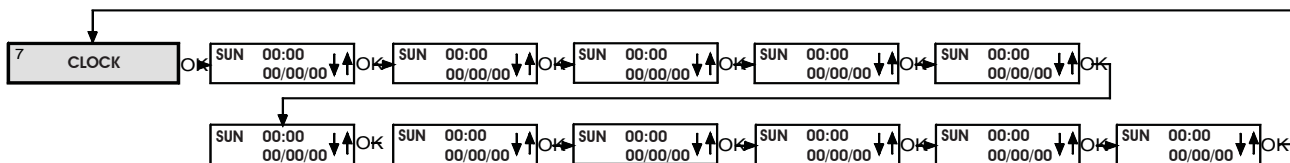

1 LANGUAGE

Selects the language for showing the messages on the display.

2 SETUP

2.1 Partial opening

Partial opening percentage

Selects the opening percentage (referred to total opening) performed in the "partial opening" operational function.

Standard value: 50%

Adjusting range: from 10% to 90%

Standard

When the "partial opening" operational function is selected, sensor activation always causes a partial opening command.

No Standard

When the "partial opening" operational function is selected, simultaneous activation of the internal and external sensors commands total opening.

2.2 Pause time

On

Pause time enabled in the "automatic" operational function.

Pause time value

If pause time is enabled, it can be set.

Standard value: 2 sec.

Adjusting range: from 0 to 30 sec. in 1 sec. steps

Off

Pause time is disabled and the leaves begin to close as soon as the command elements (e.g.sensors) become inactive.

2.3 Night pause time

Night pause time value

It sets pause time in the "night" operating function when a command is given on the KEY input.

Standard value: 8 sec.

Adjusting range: from 2 to 240 sec in steps of 2.

2.4 Anti intruder

On

In "Automatic" operating mode, the door opposes manual opening attempts by means of contrary force.

During the attempt to open, an alarm is signalled on the control board and on the SD-Keeper (alarm #3 - forced door).

With the door closed, the board continues powering the motor during closing, except when the automated system operates on the battery while the motor is locked.

Off

In "automatic" operating mode, when manual opening is attempted, the door opens automatically and re-closes after any pause time.

 *In the "night" operational function, the anti-intruder is always active.*

2.5 Obstacle detection

Closing: Standard

If an obstacle is detected during closing, the door re-opens.

Closing: No Standard

If an obstacle is detected for 3 consecutive times at closing, the door stops in open position, and causes an alarm signal on the control board and on SD-Keeper (alarm No.9 - obstacle during closing).

To restore operation, resetting is necessary either from the control board or from SD-Keeper.

Opening: Standard

If an obstacle is detected during opening, the door stops for one second and then re-closes.

Opening: No Standard

If an obstacle is detected for 3 consecutive times at opening, the door stops in closed position, and causes an alarm signal on the control board and on SD-Keeper (alarm No.8 - obstacle during opening).

To restore operation, resetting is necessary either from the control board or from SD-Keeper.

3 BATTERY

3.1 Battery kit

Off

Battery kit not installed.

On

Battery kit installed.

3.2 Bat. operation

Standard

If there is a power cut and the operating function is other than "Night", the door continues operating normally until the battery has sufficient charge reserve to perform at least one emergency movement.

The last movement operation to be executed is the one selected with function 3.3.

No Standard

In the event of a power cut, the door executes only the moving operation selected with function 3.3.

As of firmware version 4.5 :

Battery operation and partial opening:

With the last opening motion (No Standard) it immediately effects total opening.

Battery operation and opening safety:

With the last opening motion (No Standard) The door opens, with opening safety engaged, at low speed.

3.3 Last operat.

Opening

During battery operated functioning, the last moving operation is opening (see also function 3.2).

Closing

During battery operated functioning, the last moving operation is closing (see also function 3.2).

3.4 Night batt.



Not available in the A140 AIR 140 automated system.

4 LOCK

4.1 Kit lock

On

Motor lock installed.

Night

The motor lock locks the leaves only in the "night" operational function.

One way+Night

The motor lock locks the leaves in the "night" and "one way" operational functions.

Always

The motor lock locks the leaves whenever they close, irrespective of the set operational function.

Off

Motor lock not installed.

4.2 Night Lock

Standard

In the "night" operational function, with discharged batteries, the motor lock keeps the leaves locked.

No Standard



Not available in the automated system

4.3 Surveillance

Off

Surveillance device on motor lock not installed.

On

Surveillance device on motor lock installed.

5 DIAGNOSTICS

5.1 SDM L

The software of the control board to which SD-Keeper is connected is shown.

5.2 Nr cycle

The count (non resettable) of the cycles effected by the door is shown.

5.3 Alarm n°

The number and description of the current alarm are shown.

N°	DESCRIPTION	MEANING
	ENERGY SAV.	Operating on low battery consumption
2	BAT. OPERATION.	Door operating on battery
3	FORCED OPEN	Door forced opening in progress
4	FLAT BATTERY	Battery discharged; emergency movement not guaranteed (only on control board display)
6	EMERG 2 ON	Emergency 2 input active
7	EMERG 1 ON	Emergency 1 input active
8	OBST. IN OPEN.	Opening obstacle detected 3 successive times; Reset necessary to restore operation
9	OBST. IN CLOS.	Closing obstacle detected 3 consecutive times; Reset necessary to restore operation
10		Motor lock locked in closed position
11		Motor lock locked in open position (with surveillance kit only)
12		Incorrect power supply to motor
13		Sensor monitoring test 2 failed on input P2
14		Sensor monitoring test 1 failed on input P1
15		Setup not possible
22		Initialisation process not possible on motor: too much friction
24		Motor malfunctions
25		control board faulty

Reset

Executes reset procedure.

6 ADVANCED MENU

PASSWORD

To access the advanced menu, insert the 4-digit password (default 0000).

1 OPERATION PARAMETERS

1.1 Closing speed

Sets door speed for closing.
Standard value: level 3.
Adjusting range: from 1 to 10

1.2 Opening speed

Sets door speed for opening.
Standard value: level 10 (maximum speed)
Adjusting range: from 1 to 10

1.3 Deceleration width

Sets the deceleration width of the door during opening and closing.
Standard value for opening and closing : 0 cm
Adjustment: from 0 to 120 cm

1.4 Slow down speed

Speed

Sets speed level during deceleration.
Standard value: low
Adjusting range: high / medium / low

2 IN/OUT SETUP

2.1 Emerg 1

2.2 Emerg 2

Sets the effect of the emergency commands (Emerg1 and Emerg2 inputs on control board).
Standard setting EMERG 1: Stop/No memory/NO
Standard setting EMERG 2: Open/Speed: Standard/No memory/NO

Open

Activating this command opens the door.

Close

Activating this command closes the door.

Stop

Activating this command stops the door.



the EMERG1 command has priority over EMERG2

Speed: Standard

The door opens or closes (according to setting) at normal speed.

Speed: No Standard

The door opens or closes (according to setting) at slow speed.

No memory

In order to keep the emergency active, the command must be maintained active (on release, the door returns to normal operation).

With Memory

A pulse keeps the emergency operational;
To restore operation, resetting is necessary either from the control board or from SD-Keeper.

No
Normally open input.
Nc
Normally closed input.

2.3 Photocells

 **WARNING:**
TO SET PARAMETERS OF MENU 2.3 PHOTOCELLS, USE THE DISPLAY ONLY. DO NOT SET PARAMETERS FROM SD-KEEPER .

2.4 Sensors

Sets the status of "external radar" and "internal radar" commands (E-Det and I-Det inputs on control board).

No
Normally open input.
Nc
Normally closed input.

2.5 Key

Sets the status of the "key" command (Key input on the control board).

No
Normally open input.
Nc
Normally closed input.

2.6 Out 1

Sets function or status associated with individual outputs on the control board.
Standard setting OUT 1: Gong/NO

 **The outputs OUT2 and OUT3 Not available in the automated system**

Function/Status
The output is activated according to selection:

SELECTION	OUTPUT ACTIVATION
OPEN	Until the door is open
MOVING	Until door is moving
NOT CLOSED	Until door is not closed
ALARM	Until the door is in alarm status
GONG	Intervention of photocells activates the output for 1 sec. at 0.5 sec. intervals until release.
LIGHT	In "night" operational function, when the door is commanded to open, the output is activated for 60 sec.
INTERLOCK(*)	The output is activated to create an interlock between the doors

(*) The "interlock" function cannot be selected but is automatically set on the OUT1 output when the interlock is activated (see Various/Interlock).

No
Normally open output.

Nc
Normally closed output.

3 VARIOUS

3.1 Stand Setup

Used for checking if any non-standard programming operation was effected.

Standard

If no function was modified with respect to the standard programming, an asterisk is shown.
If the asterisk is not present, press the "OK" key and all standard programming functions are reset.

No Standard

If at least one function was modified with respect to the standard programming, an asterisk is shown.

3.2 Interlock

The interlock function makes it possible to control two sliding doors (master and slave) so that opening of one depends on closing of the other and vice versa.

Off

Interlock function not active.

On

Activates the interlock function.

Master

The master door (usually the internal one).

Slave

The slave door.

No Memory

With interlock operation, you must wait for one door to re-close before commanding the other to open: any opening pulses sent during the operating cycle of the first door, have no effect.

With Memory

With interlock operation, there is no need to wait for one door to re-close before commanding the other to open: any opening pulses sent during the operating cycle of the first door are memorised, and the second door opens automatically as soon as the first door closes.

3.3 Elastic kit

The elastic kit is a mechanical accessory that, after installation, enables the anti-panic opening of the leaves in the event of a power cut.

Off

Elastic kit not installed.

On

Elastic kit installed.

Standard - No Standard

When power is supplied again after a power cut, the door automatically executes the necessary movement to reset the device.

Exception: door set in manual mode.

 **Important!: during the automatic reset of the system, the anti-crushing function is disabled.**

4 CHANGE PASSWORD

Sets the new password for accessing the advanced menu (4 digits).

7 CLOCK

Sets the current day, time and date.

8 TIMER

Off

Timer not activated.

On

Timer activated: the operating time bands set in "9 Timer Programming" are enabled.

When the timer is activated, a "T" appears at the side of the time shown on the display and the SD-Keeper will not allow any operational selection.

The battery inside the SD-Keeper maintains the clock in operation even if power is not supplied; if correct time is lost (e.g. black-out and discharged battery), a flashing asterisk appears in place of the "T" and the timer is disabled.

9 TIMER PROGRAMMING

With the timer, you can create up to 5 different time bands for each day of the week (by setting the band starting time) and assign an operational function to each time band.

When the SD-Keeper's internal clock reaches the starting time of a band, the associated operating function is automatically set, and the door remains in this condition until the subsequent band intervenes.

Permanent connection of the SD-Keeper+Display is necessary for correct management of time bands.

Selecting the day

Selects the day of the week to create time bands.

If you select "All days", any time bands defined subsequently are included in all days of the week.

Function

Sets the operating function to be associated with the time band by referring to the following table:

FUN	MEANING
0	NO FUNCTION
1	AUTOMATIC TWO-WAY TOTAL
2	AUTOMATIC ONE WAY TOTAL
3	AUTOMATIC TWO-WAY PARTIAL
4	AUTOMATIC ONE WAY PARTIAL
5	DOOR TOTALLY OPEN
6	DOOR PARTIALLY OPEN
7	MANUAL
8	NIGHT

Time band starting time

Sets the activation time for the time band.

There is no need for the time bands to be in chronological order.

TIMER PROGRAMMING EXAMPLE-

We wish to program a door operating at the following times:

- from MONDAY to FRIDAY:
 - from 8 a.m. in AUTOMATIC TWO-WAY TOTAL
 - from 6 p.m. in AUTOMATIC ONE WAY TOTAL
 - from 7 p.m. in NIGHT
- SATURDAY and SUNDAY: NIGHT for the whole day

Proceed as follows:

select ALL DAYS and set the following:

TIME BAND 1 : FUN. 1 8 a.m.
 TIME BAND 2 : FUN. 2 6 p.m.
 TIME BAND 3 : FUN. 8 7 p.m.

TIME BAND 4 : FUN. 0
 TIME BAND 5 : FUN. 0

select SAT and set the following:

TIME BAND 1 : FUN. 0
 TIME BAND 2 : FUN. 0
 TIME BAND 3 : FUN. 0
 TIME BAND 4 : FUN. 0
 TIME BAND 5 : FUN. 0

select SUN and set the following:

TIME BAND 1 : FUN. 0
 TIME BAND 2 : FUN. 0
 TIME BAND 3 : FUN. 0
 TIME BAND 4 : FUN. 0
 TIME BAND 5 : FUN. 0



WARNING:

For the interlock configuration with sensors or keys adhere to the EN16005 standard using monitored sensors or using the LOW ENERGY mode.

Interlock with internal sensors

This application is recommended when the distance between the two doors is sufficient to avoid interference in the detection ranges of the two internal sensors.

- Make the connections between the J6 terminal boards of the two control boards and the sensors as shown in figure 66.
- Program the following functions:
 - “interlock” active on both doors,
 - select the “master” option for the internal door, and the “slave” option for the external one,
 - select, for both doors, option “interlock with no memory” or “interlock with memory” (refer to explanations in the programming flow-charts).

Important:

- The sensors must be connected ONLY to the E-DET input of the equipment;
- The interlock will operate only if both doors are set to the ONE WAY operating function.

Operation

These are the interlock operational stages:

1. The person on the outside activates sensor S1 of door A;
2. Door A opens;
3. The person enters the internal space between the two doors;
4. Door A closes after the pause time elapses;
5. The person activates sensor S3 of door B (If the “Interlock with memory” option was selected, there is no need to wait for the first door to close totally in order to activate the sensor of the second door);
6. Door B opens;
7. The person exits;
8. Door B closes after the pause time elapses.

The operation is identical if the person comes from the opposite direction.

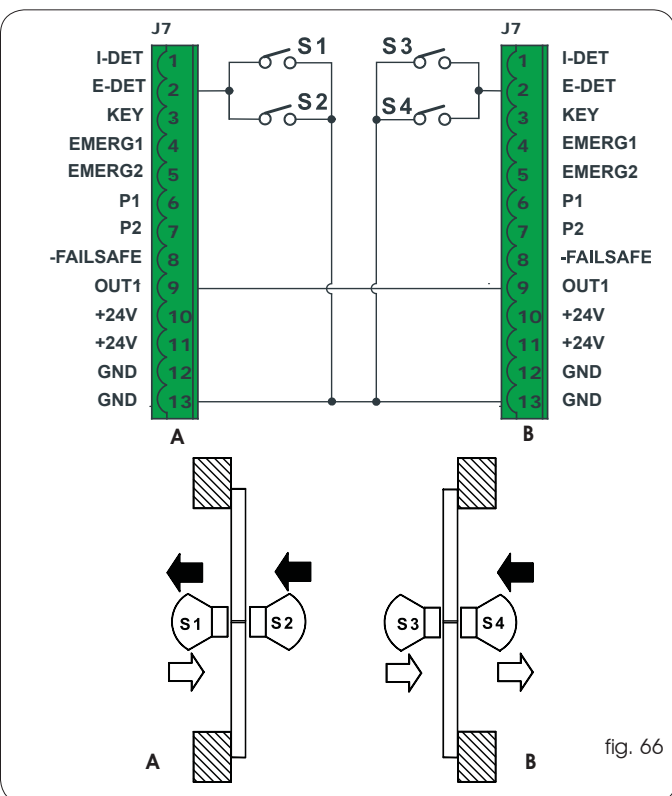

fig. 66

Interlock with push-buttons

This application is recommended if the doors are so near to one another that the two internal sensors cannot be used; two push-buttons are provided for activating the doors from the outside.

- Make the connections between the J6 terminal boards of the two control boards, of the push-buttons and additional electronic components as shown in figure 67.
- Program the following functions:
 - “interlock” active on both doors,,
 - select the “master” option for the internal door, and the “slave” option for the external one,
 - select the “interlock with memory” option for both doors (refer to explanations in the programming flow-charts).

Important:

- The push-buttons must be connected ONLY to the E-DET input of the equipment;
- The interlock will operate only if both doors are set to the ONE WAY operating function.

Operation

These are the interlock operational stages:

1. The person on the outside activates push-button P1 of door A;
2. Door A opens;
3. The person enters the internal space between the two doors;
4. Door A closes after the pause time elapses;
5. Door B opens automatically;
6. The person exits;
7. Door B closes after the pause time elapses.

The operation is identical if the person comes from the opposite direction.

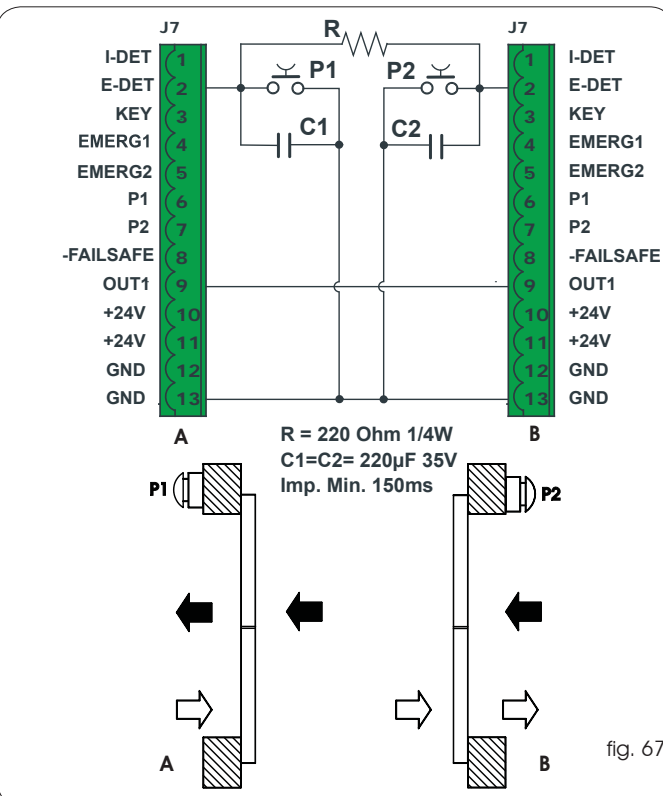

fig. 67

ACCESSORIES

MOTOR LOCK

Motor lock installation procedure:

- cut out mains power supply;
- connect the motor lock connector to J5 of board E100;
- power up.

⚠ TO AVOID DAMAGING THE MOTOR LOCK, ALWAYS ACTIVATE OR DISABLE IT WHEN NO POWER IS SUPPLIED.

In the standard configuration:

The motor lock locks the leaves only in "Night" operating function;
- if operating on batteries in the Night mode, if the batteries discharge, the motor lock continues to lock the leaves.

With SD-Keeper+Display or E100, you can change the operation of the motor lock.

ANTI-PANIC BY BREAK-OUT

This accessory enables the leaves to be opened by pressure; to install it, refer to the specific instructions.

If installing the anti-panic by break-out facility, a sensor or photocell must be connected to the EMERG1 input (via SD-Keeper+Display) configured for commanding immediate stop of the movement (STOP).

BATTERY KIT

Instructions to connect and install the battery kit:

- cut out mains power supply;
- insert the connector of the battery pack in connector J16 of board E100;
- power up the mains supply again;
- using SD-Keeper+Display, activate the "Battery Kit" and set the operating parameters you require (refer to the dedicated section in this manual);

⚠ IMPORTANT: TO AVOID DAMAGING THE BATTERY BOARD, THE BATTERY BOARD MUST ALWAYS BE ACTIVATED AND DISABLED WHILE NO MAINS POWER IS SUPPLIED

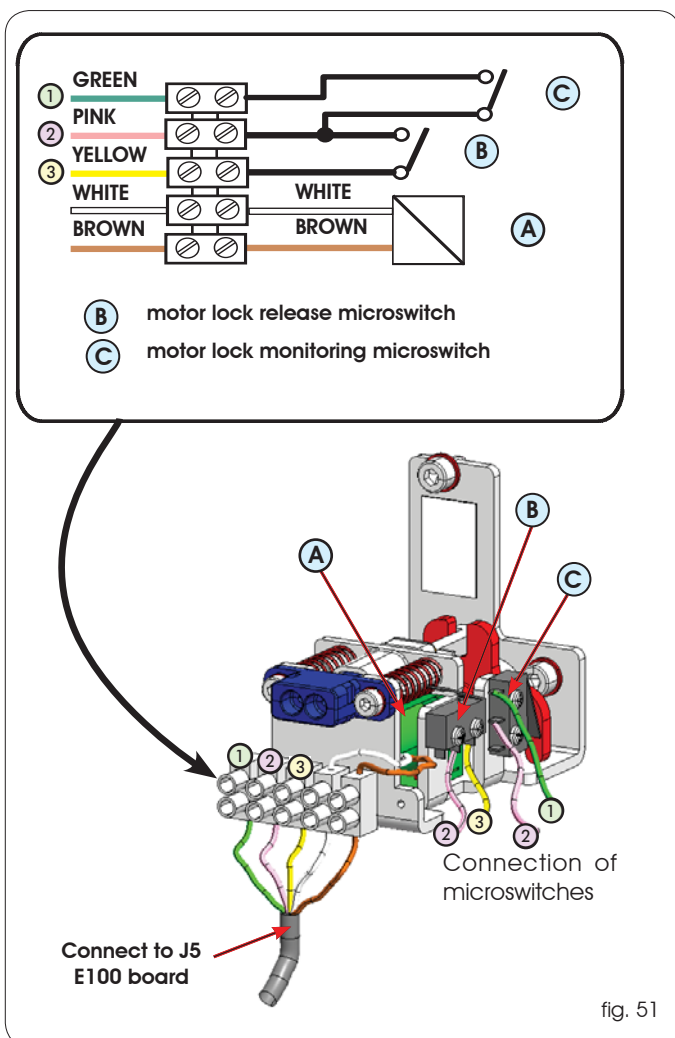

MOTOR LOCK SUPERVISION

This accessory (Fig. 51 ref. C) makes it possible to verify correct operation of the motor lock and, if it stays locked while open, signals an error via the control board or SD-Keeper.

To activate motor lock surveillance, the function must be set with the control board or SD-Keeper.

ACCESSORIES

MOTOR LOCK

Motor lock installation procedure:

- cut out mains power supply;
- connect the motor lock connector to J5 of board E140;
- power up.

⚠ TO AVOID DAMAGING THE MOTOR LOCK, ALWAYS ACTIVATE OR DISABLE IT WHEN NO POWER IS SUPPLIED.

In the standard configuration:
The motor lock locks the leaves only in "Night" operating function;

- if operating on batteries in the Night mode, if the batteries discharge, the motor lock continues to lock the leaves.
- With SD-Keeper+Display or E140, you can change the operation of the motor lock.

ANTI-PANIC BY BREAK-OUT

This accessory enables the leaves to be opened by pressure; to install it, refer to the specific instructions.

If installing the anti-panic by break-out facility, a sensor or photocell must be connected to the EMERG1 input (via SD-Keeper+Display) configured for commanding immediate stop of the movement (STOP).

BATTERY KIT

Instructions to connect the battery kit:

- cut out mains power supply;
- insert the connector of the battery pack in connector J16 of board E140;
- power up the mains supply again;
- using SD-Keeper+Display, activate the "Battery Kit" and set the operating parameters you require (refer to the dedicated section in this manual);

⚠ IMPORTANT: TO AVOID DAMAGING THE BATTERY BOARD, THE BATTERY BOARD MUST ALWAYS BE ACTIVATED AND DISABLED WHILE NO MAINS POWER IS SUPPLIED

MOTOR LOCK SUPERVISION

This accessory (Fig. 68 ref. C) makes it possible to verify correct operation of the motor lock and, if it stays locked while open, signals an error via the control board or SD-Keeper.

To activate motor lock surveillance, the function must be set with the control board or SD-Keeper.

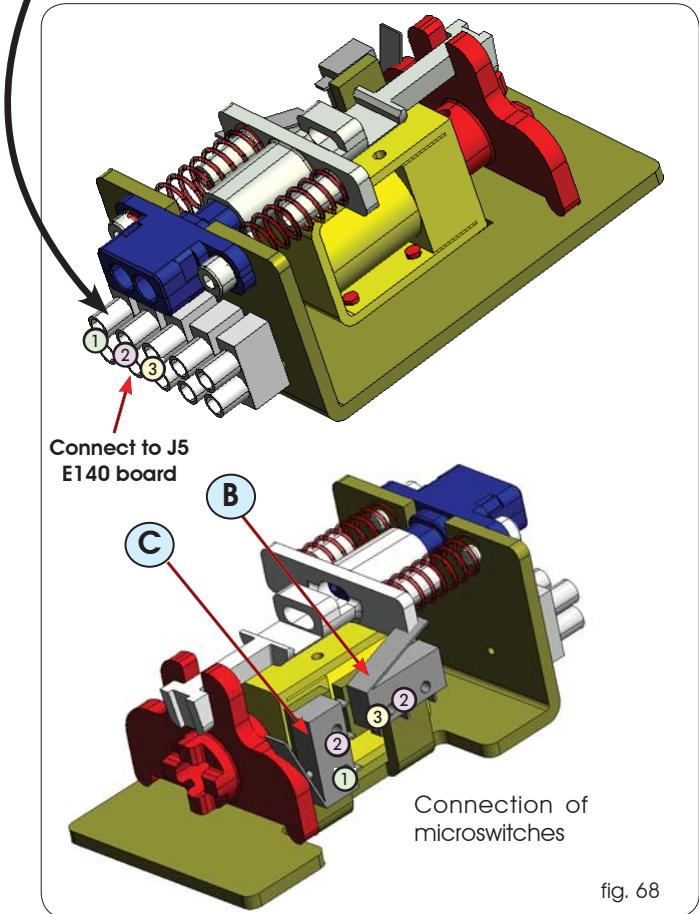
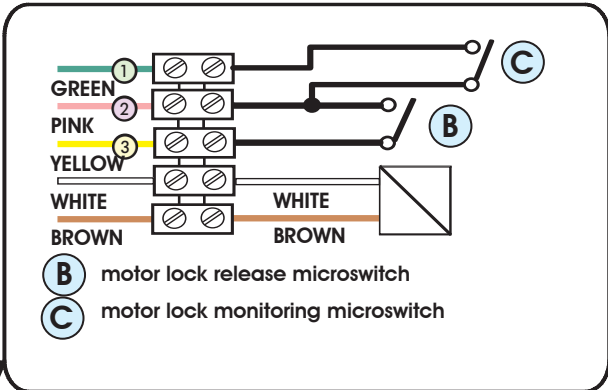

fig. 68

ENGLISH

DIAGNOSTICS GUIDE

The following is a list of the specified alarms plus the relevant explanation/solution.

SD-Keeper+Display shows the alarm number and description on the Diagnostics menu.

Only the SD-Keeper shows the type of alarm by a combination of flashing LEDs (referring to the figure on the side).

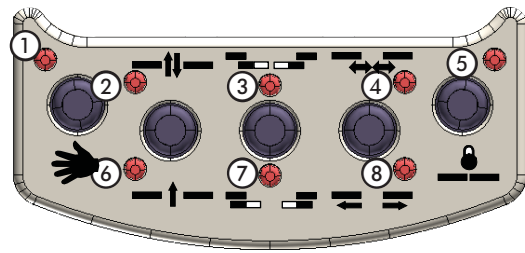

DESCRIPTION	CAUSE	NOTES	ACTIONS	LED
ENERGY SAV.	The control board is operating in battery powered low consumption mode	In this mode, SD-Keeper's back-lighting is OFF and menus cannot be scrolled on the display.	(see battery kit instructions) However, the push-buttons for changing the operating functions are active.	2
2 BAT. OPERATION	control board operating on battery		In the event of a power cut, this is the normal battery-powered operation signal However, if mains power is available, check: • is the 5x20 T2,5A fuse of the transformer in the power supply unit interrupted? • is the F2 5x20 T2,5A fuse on the control board interrupted? • Is the 230V~ mains power supply correctly connected? • Is connector J1 fitted correctly on the control board? If the alarm persists, replace the control board. If the alarm persists, replace the transformer.	3
3 FORCED OPEN	Someone is now trying to force the door.	This signal is generated only if STANDARD ANTI-INTRUDER is set.		3 7
4 FLAT-BATTERY	The battery is discharged: emergency movement is not guaranteed at changeover from mains-powered to battery-powered mode.		If the alarm goes on for more than one hour, check the following: • connections to battery • are the batteries efficient? If the alarm persists, replace the battery card. If the alarm persists, replace the batteries.	4
6 EMERG 2 ON	Emergency input 2 active.	This signal is shown whenever the EMERG2 emergency contact is active. If the WITH MEMORY function was selected for this input, the signal continues even when the contact is no longer active.	If the WITH MEMORY function was selected for the EMERG2 input, when the contact is restored, RESET is necessary to cancel the signal.	3 4
7 EMERG 1 ON	Emergency input 1 active.	This signal is shown whenever the EMERG1 emergency contact is active. If the WITH MEMORY function was selected for this input, the signal continues even when the contact is no longer active.	If the WITH MEMORY function was selected for the EMERG1 input, when the contact is restored, RESET is necessary to cancel the signal.	3 4 7
8 OBST. IN OPEN.	An obstacle was detected 3 consecutive times during the opening movement.	This signal is shown only if the following function was selected: OBSTACLE DETECTION - -> OPENING: NO STANDARD	Remove the obstacle and execute RESET to restore operation.	8
9 OBST. IN CLOS.	An obstacle was detected 3 consecutive times during the closing movement.	This signal is shown only if the following function was selected: OBSTACLE DETECTION - -> CLOSING: NO STANDARD	Remove the obstacle and execute RESET to restore operation.	7 8
10	The motor lock is locked in closed position.	This signal is shown only if the motor lock was installed: • without surveillance: the door attempts to release the motor lock 3 times and then stops in a state from which it can exit only by a RESET or by turning the emergency release knob. • with surveillance: the door stops immediately in a state from which it can exit only by a RESET or by turning the emergency release knob	Check the following: • are the motor lock connections good? • is the motor lock operating correctly? • is the motor lock surveillance kit (if any) correctly fitted and connected? If the alarm continues even after RESET, replace the motor lock card and/or the lock.	3 8
11	motor lock not closing	This signal is shown only if a SURVEILLANCE KIT was installed ON THE motor lock, and was programmed.	Check the following: • is the motor lock card inserted correctly? • are the motor lock connections good? • is the motor lock operating correctly? • is the motor lock surveillance kit correctly fitted and connected?	3 7 8
12	Incorrect power supplied to motor.		Check the following: • is connector J1 correctly fitted on control board?	4 8

13	Sensor monitoring test 2 failed on input P2	This signal is generated only if the sensor monitoring function is active.	Check the following: • sensor 2 connections • is sensor 2 in good condition and efficient?	4 7 8
14	Sensor monitoring test 1 failed on input P1	This signal is generated only if the sensor monitoring function is active.	Check the following: • sensor 1 connections • is sensor 1 in good condition and efficient?	3 4 8
15	SETUP execution is impeded in some way.	When the trouble fault is removed, SETUP starts automatically	Check the following: • the set operating function is not MANUAL, NIGHT. • operation is not battery-powered • photocells are not engaged • no emergency input is active • motor power supply absent	3 4 7 8
22	The SETUP procedure cannot be completed because excessive friction or excessive leaf weight was detected.	When this signal is generated, the display on the control board shows relative error number and the door is locked.	• cut power or set the MANUAL operating function, and then manually check if the leaves are moving correctly. • check weight of leaves	2 3 4
23	Accessory power supply +24V= dc faulty	When this signal is generated, the display of the board shows the current error and the door is locked	Check the following: • the connections and the presence of short circuits	2 3 4 7
24	A motor fault was detected during operation.	When this signal is generated, the display on the control board shows relative error number and the door is locked.	Check the following: • is connector J3 fitted correctly? • is the motor efficient? If the alarm persists, replace the control board. If the alarm persists, replace the motor.	2 8
25	control board failure		Replace the control board	2 7 8
All the LEDs of the operating functions are flashing.	No communication between SD-Keeper and control board.		Check the following: • connection length must not exceed 50 m • each connection cable must have a minimum diameter of 0.5mm ² If the alarm persists, replace the SD-Keeper. If the alarm persists, replace the control board.	

ENGLISH

TROUBLESHOOTING

The following will help you identify and solve some particular states.

	STATE	SUGGESTION
A	SD-KEEPER off	<ul style="list-style-type: none"> • no mains power supplied and the control board is battery-powered in NIGHT operating function, and in energy saving statuses. • connection to the control board is interrupted: check the connection cables and wiring between SD-Keeper and the control board • control board not operating correctly; replace the control board
B	All leds off	<ul style="list-style-type: none"> • is the 5x20 T2,5A fuse inside the power supply unit interrupted? • Is connector J1 fitted correctly on the control board? • check connection to the power supply unit • control board not operating correctly; replace the control board
C	POWER led OFF; 24V= led ON	<ul style="list-style-type: none"> • mains power not supplied and the control board is battery-powered • if mains power is being supplied, see point B
D	door NOT CLOSING and ERROR LED off	<ul style="list-style-type: none"> • photocell/s engaged • make sure that the selected operating function is not DOOR OPEN (if no SD-Keeper is installed, make sure that input 8 of the J6 terminal board is not jumper connected to the negative) • make sure that the selected operating function is not MANUAL • check motor connection • check if power is being supplied to the motor (VMOT LED ON)
E	door NOT OPENING and ERROR LED off	<ul style="list-style-type: none"> • make sure that the selected operating function is not MANUAL • make sure that the selected operating function is not NIGHT (if no SD-Keeper is installed, make sure that input 7 of the J6 terminal board is not jumper connected to the negative) • check motor connection • make sure that the motor lock is not locked • check if power is being supplied to the motor (VMOT LED ON)
F	door CLOSES instead of OPENING and vice versa	<ul style="list-style-type: none"> • reverse the position of dip-switch 4 on the control board and execute a SETUP
G	door moving for short distances only	<ul style="list-style-type: none"> • check if encoder connector J17 is correctly inserted • check condition of the encoder • check the condition of the encoder connection flat cable
H	door movements very slow	<ul style="list-style-type: none"> • using the SD-Keeper+Display, check if the selected speed levels are as required • using the SD-Keeper+Display, check if the selected deceleration distances are as required
I	the door accelerates and decelerates suddenly during an acceleration phase in opening and / or closing.	<ul style="list-style-type: none"> • change to display the values OF, CF and tF . • Reduce the value Ar to 0

SDK-LIGHT

SDK-Light is used to select the operational functions of FAAC sliding or swing-leaf automatic doors and to display their status. The active LED corresponds to the selected operational function.

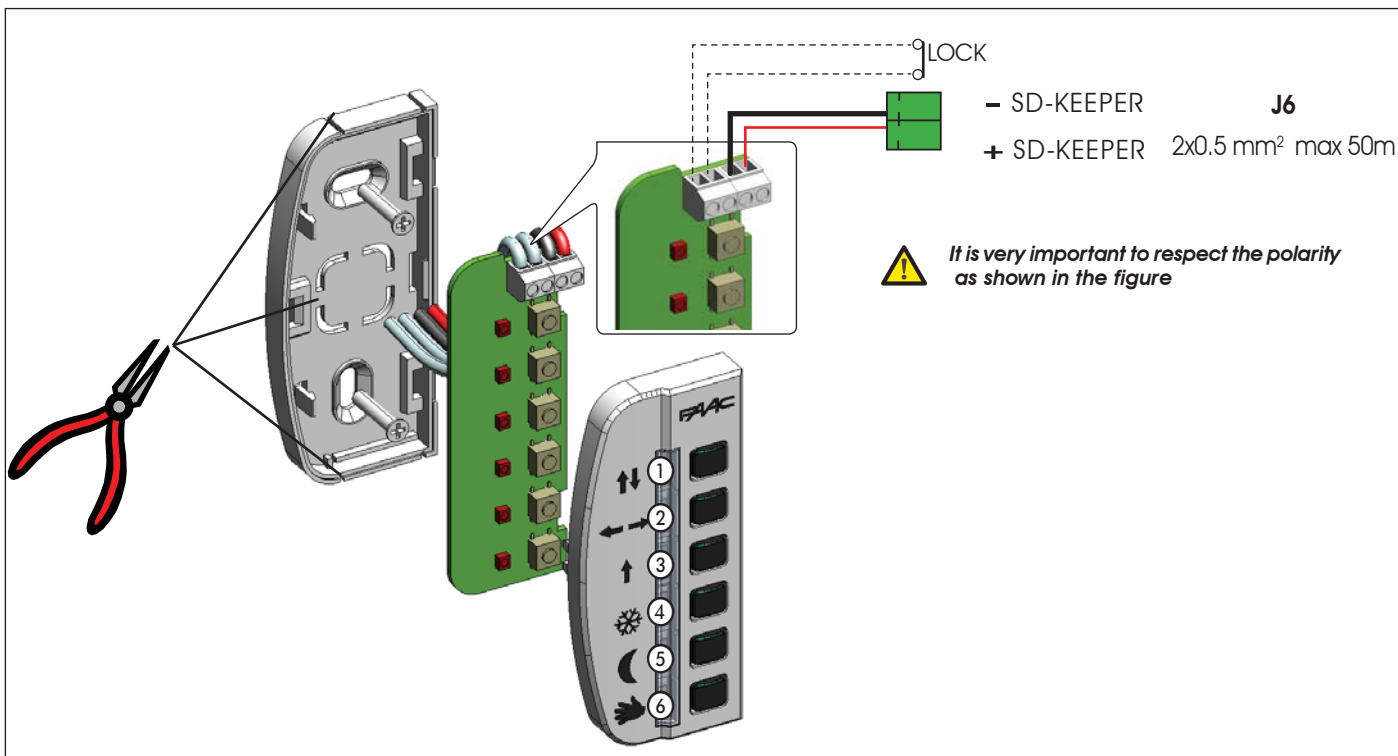

ENGLISH

①	↕	TOTAL AUTOMATIC TWO-WAY	④	❄	PARTIAL AUTOMATIC TWO-WAY
②	↔	DOOR OPEN	⑤	☾	NIGHT
③	↑	TOTAL AUTOMATIC ONE-WAY	⑥	👤	MANUAL

DIAGNOSTIC

In the event of an alarm, a combination of flashing LEDs interrupts the normal display of the function for 5 sec. in order to indicate the fault. See tables below.

A100-A140 AIR

n. err.	/	1	2	3	4	6	7	8	9	10	11	12	13	14	15	18	20	22	24	25
①	↕	●	○	○	○	○	○	○	○	○	○	○	○	○	○	●	●	●	●	●
②	↔	○	○	●	●	○	●	●	○	●	●	○	○	●	●	●	●	●	○	○
③	↑	○	○	○	○	●	●	○	○	○	○	○	○	○	○	○	○	○	○	○
④	❄	○	●	○	○	○	○	○	○	○	○	○	○	○	○	○	○	○	○	○
⑤	☾	○	○	○	○	○	○	○	○	○	○	○	○	○	○	○	○	○	○	○
⑥	👤	○	○	○	○	○	○	○	○	○	○	○	○	○	○	○	○	○	○	○

led ● = ON ○ = OFF



Please refer to the number indicated on the first line for the description of the errors and consult the instructions of the automatic door being used.

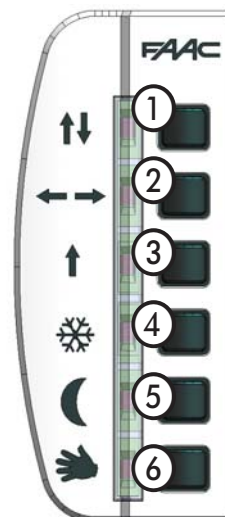

SPECIAL FUNCTIONS

SETUP		① + ⑥ 5 sec,
LOCK / UNLOCK		② + ⑤ 5 sec,
RESET		③ + ④

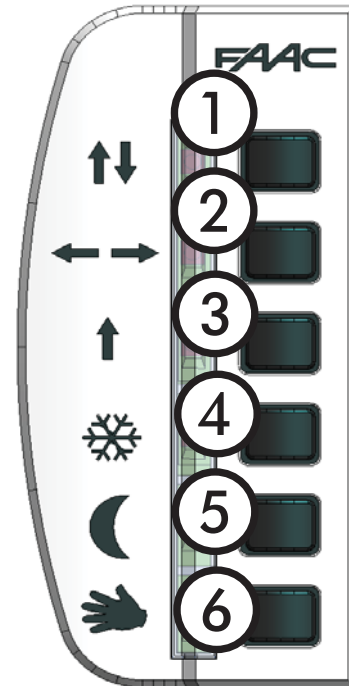

ENGLISH

Setup

Setup is the door initialisation function during which parameters are self-learned. To activate, simultaneously press keys ① and ⑥ for 5 sec.

Reset

Reset is the function for restoring normal operating conditions after some types of alarm have been signalled.

To activate, simultaneously press keys ③ and ④ .

Lock

When active, the Lock function disables SD-Keeper.

To activate (and de-activate), simultaneously press keys ② and ⑤ for 5 sec.

SEDE - HEADQUARTERS

FAAC S.p.A.

Via Calari, 10
40069 Zola Predosa (BO) - ITALY
Tel. +39 051 61724 - Fax +39 051 758518
www.faac.it - www.faacgroup.com

ASSISTENZA IN ITALIA

SEDE

tel. +39 051 6172501
www.faac.it/ita/assistenza

MILANO

tel +39 02 66011163
filiale.milano@faacgroup.com

PADOVA

tel +39 049 8700541
filiale.padova@faacgroup.com

ROMA

tel +39 06 41206137
filiale.roma@faacgroup.com

TORINO

tel +39 011 6813997
filiale.torino@faacgroup.com

FIRENZE

tel. +39 055 301194
filiale.firenze@faacgroup.com

SUBSIDIARIES

AUSTRIA

FAAC GMBH
Salzburg, Austria
tel. +43 662 8533950
www.faac.at

FAAC TUBULAR MOTORS
tel. +49 30 56796645
faactm.info@faacgroup.com
www.faac.at

GERMANY

FAAC GMBH
Freilassing, Germany
tel. +49 8654 49810
www.faac.de

FAAC TUBULAR MOTORS
tel. +49 30 5679 6645
faactm.info@faacgroup.com
www.faac.de

BENELUX

FAAC BENELUX NV/SA
Brugge, Belgium
tel. +32 50 320202
www.faacbenelux.com

FAAC TUBULAR MOTORS
Schaapweg 30
NL-6063 BA Vlodrop, Netherlands
tel. +31 475 406014
faactm.info@faacgroup.com
www.faacbenelux.com

AUSTRALIA

FAAC AUSTRALIA PTY LTD
Homebush – Sydney, Australia
tel. +61 2 87565644
www.faac.com.au

INDIA

FAAC INDIA PVT. LTD
Noida – Delhi, India
tel. +91 120 3934100/4199
www.faacindia.com

SWITZERLAND

FAAC AG
Altdorf, Switzerland
tel. +41 41 8713440
www.faac.ch

CHINA

FAAC SHANGHAI
Shanghai, China
tel. +86 21 68182970
www.faacgroup.cn

NORDIC REGIONS

FAAC NORDIC AB
Perstorp, Sweden
tel. +46 435 779500
www.faac.se

POLAND

FAAC POLSKA SP.ZO.O
Warszawa, Poland
tel. +48 22 8141422
www.faac.pl

UNITED KINGDOM

FAAC UK LTD.
Basingstoke - Hampshire, UK
tel. +44 1256 318100
www.faac.co.uk

SPAIN

F.A.A.C. SA
San Sebastián de los Reyes.
Madrid, Spain
tel. +34 91 6613112
www.faac.es

RUSSIA

Faac RUSSIA
Moscow, Russia
www.faac.ru

FRANCE

FAAC FRANCE
Saint Priest - Lyon, France
tel. +33 4 72218700
www.faac.fr

U.S.A.

FAAC INTERNATIONAL INC
Jacksonville, FL - U.S.A.
tel. +1 904 4488952
www.faacusa.com

MIDDLE EAST

FAAC MIDDLE EAST BRANCH
Dubai Airport Free Zone - Dubai, UAE
tel. +971 42146733
www.faac.ae

FAAC FRANCE - AGENCE PARIS
Massy - Paris, France
tel. +33 1 69191620
www.faac.fr

FAAC INTERNATIONAL INC
Fullerton, California - U.S.A.
tel. +1 714 446 9800
www.faacusa.com

FAAC FRANCE - DEPARTEMENT VOLETS
Saint Denis de Pile - Bordeaux, France
tel. +33 5 57551890
fax +33 5 57742970
www.faac.fr