

CoMETA



INTERLOCKING SECURITY PORTALS

COMETA SPA



SECURITY PORTALS

with interlocking door system

SECURITY PORTALS (interlocking door system)

Classic Portals, square base

Co132 | Co135



Co135.R60
(R= ribassata / lowered)



Co135.60
with ramp



Professional Console
for Portal functions
control



Energy saving
Thermal insulation: the outside air
doesn't enter directly into contact with
the internal one.

Main features

- Monoblock (High Security Level)
- Self-managed High Security Portal with weighing cell system:
 - Single passage checking system (Anti-hostage system)
 - Abandoned object detection (weight higher than 200 grams)
- Possibility of embedding in floor up to 65mm
- Doors and side walls: Bulletproof laminated glass 26/27mm BR3/S EN1063 and anti-burglary P6B EN356
- Corner construction is available only for Co135 model
- Paint finish: embossed, according to RAL color scale, or Stainless Steel covering
- Traffic Light Panels & Multilingual synth-voice for transit communications
- Portal Console with digital display and menu-guided commands
- **Co135C Armored versions:** with armored steel door



Co132



Co135C0
Armored door + bulletproof side glass



Co135C3
Armored door + «blind» sides

Optionals

- Emergency exit management
- Camera
- Card reader
- IR sensor for people presence monitoring
- Biometric registration system: Biobank
- Anti masking System: Face Detection
- CEIA Metal Detector

Model	Overall Dimensions W x D x H (mm)	Width of Passage (mm)	Floor Thickness (mm)	Weight (Kg)	Certified Glasses
Co132.60	995 x 995 x 2400	600	65	800	Bulletproof BR3/S EN1063
Co135.60	1050 x 1050 x 2400	600	65	800	
Co135.R60	1050 x 1050 x 2340	600	30	800	Anti-burglary P6B EN356
Co135.C	1050 x 1050 x 2400	600	65	900	

*These models can be made of stainless steel.

SECURITY PORTALS (interlocking door system)

Cylinder Portals, round base

Co136 | Co137 | Co138



Professional Console for Portal functions control

Main features

- 40/10 steel pressure bent sheet
- Co136 and Co137 monoblock, Co138 removable structure
- Self-managed Security Portal with weighing floor system (abandoned object detection, weight higher than 200 grams)
- Single passage checking system (anti-hostage system)
- Doors and side walls:
 - Laminated glass 20/21 mm EN1063-BR2/S (Co138) EN356-P6B
 - Laminated glass 23/24 mm EN1063-BR2/S (Co137) EN356-P6B
 - Laminated glass 26/27 mm EN1063-BR3/S (Co136) EN356-P6B
- Paint finish: embossed, according to RAL color scale, is possible also the Stainless Steel covering
- Traffic Light Panels & Multilingual synth-voice for transit communications
- Portal Console with digital display and menu-guided commands

Optionals

- Emergency exit management
- Camera
- Card reader
- IR sensor for people presence monitoring
- Biometric registration system: Biobank
- Anti masking System: Face Detection
- CEIA metal detectors:
 - Metal detector CEIA 02PN8HIPE/CF
 - Metal detector CEIA 02PN8HIPE

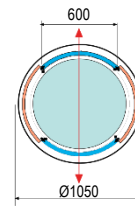

Co136.60

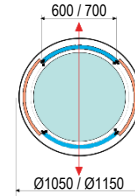

Co137.60
Co137.70

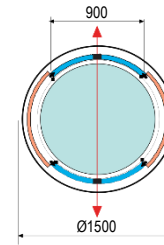

Co138.S90



Usable by people with disabilities



Energy saving
Thermal insulation: the outside air doesn't enter directly into contact with the internal one.

Model	Overall Dimensions Ø x H (mm)	Width of Passage (mm)	Floor Thickness (mm)	Weight (Kg)	Structure
Co136.60	1050 x 2400	600	65	800	Monoblock
Co137.60	1050 x 2350	600	20	900	Monoblock
Co137.70	1150 x 2350	700	20	900	Monoblock
Co138.S90	1500 x 2400	900	25	1300	Removable

*These models can be made of stainless steel

SECURITY PORTALS (interlocking door system)

Panorama Portal, ellipse base

Co139



Professional Console
for Portal functions
control



Main features

- Monoblock: 40/10 Steel pressure bent sheet
- Self-managed Security Portal with weighing floor system (abandoned object detection, weight higher than 200 grams)
- Single passage checking system (anti-hostage system)
- Doors and side walls: Laminated glass 20/21mm EN1063-BR2/S - EN356-P6B
- Paint finish: embossed, according to RAL color scale
- Traffic Light Panels & Multilingual synth-voice for transit communications
- Portal Console with digital display and menu-guided commands

Optionals

- Emergency exit management
- Camera
- Card reader
- IR sensor for people presence monitoring.
- Biometric registration system: BIOBANK
- Anti masking System: FACE DETECTION
- CEIA Metal Detector: 02PN8HIPE large
- Secondary door for service access

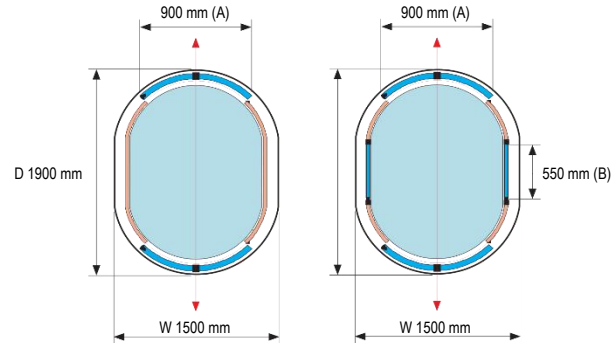

Energy saving
Thermal insulation: the outside air doesn't enter directly into contact with the internal one.



Usable by people
with disabilities



Model	Overall Dimensions W x D x H (mm)	Width of Passage (mm)	Width of Passage (mm)	Floor Thickness (mm)	Weight (Kg)
Co139	1500 x 1900 x 2400	900 (A)	550 (B)	25	1500

SECURITY PORTALS (interlocking door system)

Half moon Portal

Co140



Professional Console
for Portal functions
control



Main features

- Monoblock: 30/10 Steel pressure bent sheet
- Suitable for disabled person transit
- Weighing floor system, for:
 - Presence person detection
 - More than one person detection (anti-hostage)
 - Abandoned object detection (weight higher than 200 grams)
- Doors and side walls: Laminated glass 18/19mm bulletproof BR1/S EN1063 - anti-burglary P5B EN356
- Paint finish: embossed, according to RAL color scale, is possible also the Stainless Steel covering
- Internal Emergency button with alarm functions
- Traffic Light Panels & Multilingual synth-voice for transit communications
- Portal Console with digital display and menu-guided commands

Optionals

- Emergency exit management
- Camera
- Card reader
- IR sensor for people presence monitoring.
- Biometric registration system: BIOBANK
- Anti masking System: FACE DETECTION
- CEIA metal detector
 - Metal detector CEIA 02PN8HIPE/CF Large
 - Metal detector CEIA 02PN8HIPE
 - Metal detector CEIA 02PN7

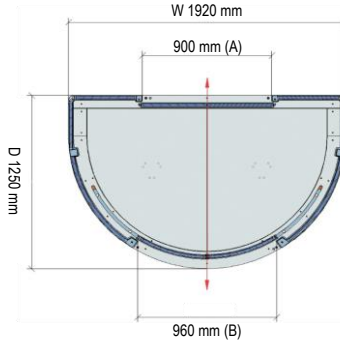

Energy saving
Thermal insulation: the outside air
doesn't enter directly into contact with
the internal one.



Usable by people
with disabilities

Model	Overall Dimensions W x D x H (mm)	Width of Passage (mm)	Width of Passage (mm)	Floor Thickness (mm)	Weight (Kg)
Co140	1920 x 1250 x 2400	900 (A)	960 (B)	25	1100

SECURITY PORTALS (interlocking door system)

Crystal Portal, glass-body

Co143



Professional Console
for Portal functions
control



Main features

- Removable structure (installed on the existing floor)
- Glass structure
- Glasses: laminated, bulletproof BR1/S EN1063
Side glasses: anti-burglary 18/19mm P5B EN356
Door glasses: anti-burglary 12/13mm P4B EN356
- Paint finish: according to RAL color scale
- Single passage checking system (anti-hostage system)
- Infrared sensors for person detection
- Infrared sensors for door opening request
- Internal Emergency button with alarm functions
- Traffic Light Panels & Multilingual synth-voice for transit communications
- Portal Console with digital display and menu-guided commands

Optionals

- Emergency exit management
- Camera
- Card's reader
- IR sensor for people presence monitoring
- Biometric registration system: BIOBANK
- Anti masking System: FACE DETECTION



Energy saving

Thermal insulation: the outside air doesn't enter directly into contact with the internal one.

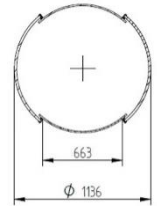
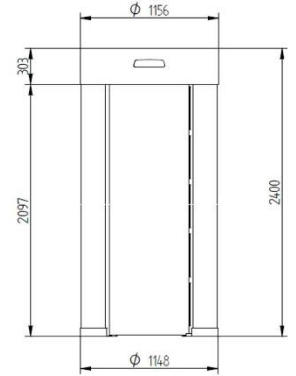

Model	Dimensions (mm)	Width of Passage (mm)	Weight (Kg)	Glasses
Co143	Ø1156 x H2400	660	450	Bulletproof BR1/S EN1063 Side glasses: Anti-burglary:18/19mm P5B EN356 Door glasses: Anti-burglary 12/13mm P4B EN3456

SECURITY PORTALS (interlocking door system)

Manual doors Portal

Coi122.70 / Coi122.90



Main features

- Monoblock: 40/10 Steel pressure bent sheet
- Internal door and side walls: Laminated glass 23/24mm bulletproof BR2/S EN1063 - anti-burglary P6B EN356
- Paint finish: embossed, according to RAL color scale
- Possibility of embedding in floor up to 35mm
- Traffic Light Panels & Multilingual synth-voice for transit communications
- High Security Locks with Anti-burglary Top Grade (level 7) certification according to EN12209
- Internal Emergency button with alarm functions
- Traffic Light Panels & Multilingual synth-voice for transit communications
- Portal Console with digital display and menu-guided commands

Optionals

- Emergency exit management
- Card reader
- Camera
- Biometric registration system: BIOBANK
- Anti masking System: FACE DETECTION
- CEIA metal detectors:
 - Metal detector CEIA 02PN8HIPE/CF
 - Metal detector CEIA 02PN8HIPE
 - Metal detector CEIA 02PN7



Energy saving
Thermal insulation: the outside air doesn't enter directly into contact with the internal one.

Certifications

	Anti-burglary protection	Bullet proof protection
Glass - External door	P6B UNI EN356	BR2/S EN1063
Glass - Internal door and lateral sides	P6B UNI EN356	BR3/S EN1063
Locks	Class 7 UNI EN12209	
Cylinder	Class 6 UNI EN1303	

Anti-burglary Grade 7 Locks certified according to EN12029

Electric Lock single action, closed when not powered. Supplied with temporary unlocking control with an excludible key (or handle). **Professional Lock with self-locking bolt system (patented).**

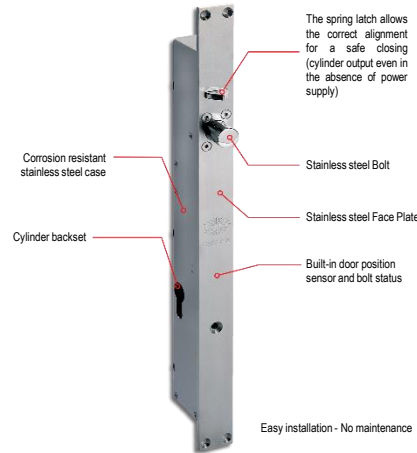

Model	Overall Dimensions (mm) W x D x H	Width of Passage - C (mm)
Coi122.701	1150x1150x2300	700
Co122.901	1350x1050x2300	900
Coi122.703	1150x1150x2300	700
Coi122.903	1350x1350x2300	900
Coi122.704	1150x1150x2300	700
Coi122.904	1350x1350x2300	900

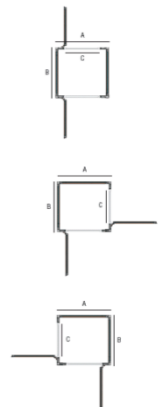

FUNCTIONS AND OPERATION

INTERLOCKING SECURITY PORTALS

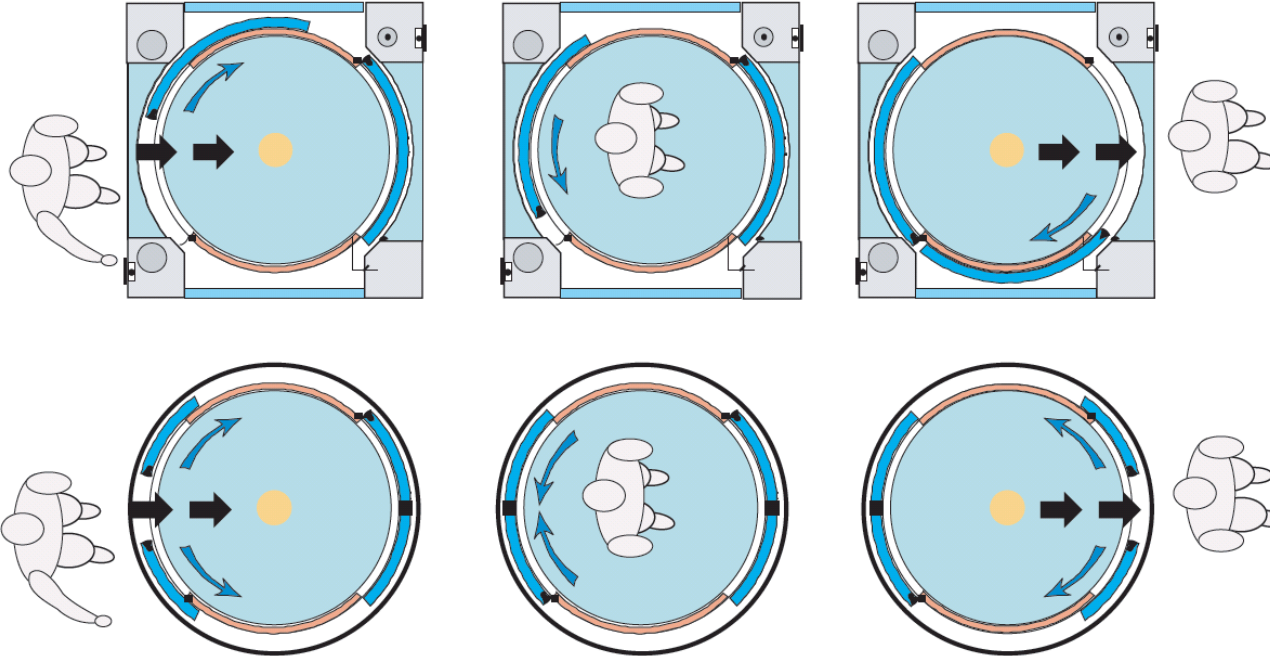

Mode of Operation

The doors are always locked shut when are in the rest position. An authorized signal let the booth opens the first door, allowing the user to step into the booth (where a presence is detected by checking weight increase on the floor, side panels and doors). The first door closes and the second door opens, thus allowing the user to pass through. When the unit is vacated, the system closes the second door automatically, resetting the cycle.

Prevention fo Multi Person Entry

Electronic weight sensing determines if more than one person is present within the booth. The booth is set with a predetermined, but adjustable anti hostage threshold (upper and lower limit).

As an authorized user stands in the booth, it confirms acceptance of the occupant and authorises the door to close. Should the misured weight not be authorized, i.e. more than one person present or over weight non-permitted additional baggage, a vocal synthesiser will ask the occupants to leave the booth.

Once the occupants have vacated the booth, the door will close and the system will automatically reset.

Standard upper and lower weight limit range from 1 to 140 Kg. For heavy requirements a maximum setting of 160Kg. Is also available.

Passage Confirmation

Depending on the access control functions (installed in the cabin), the system will open the second (exit) door when an valid passage is confirmed. Otherwise, when the user's passage is rejected, the system will lock the second (exit) door and will open again the first (entrance) door, just to let the user get out.

SECURITY AIRLOCK SYSTEM

WITH CERTIFIED METAL DETECTOR HIPE CF



Security Airlock System

CoMETA production includes security airlock system designed to integrate the Metal Detector CEIA HIPE CF, which allows a high discrimination between metal personal objects and firearms. This feature drastically reduces the "improper" alarms, limiting the operator's intervention and making the passages more fluid.

The graph compares two systems installed in the same context, where a sample of 100 people passed through in each of the two systems.

Main features

- Digitally adjustable sensitivity with a wide range of values
- International Standards: Direct selection of the International Security Standards
- Very high discrimination
- Very high immunity to electromagnetic and mechanical interference
- All functions programmable and controlled by a microprocessor
- Programming: via built-in keypad and RDU or RS232/RS485 serial connection to PC or computer network
- Programming access protected by both a mechanical lock and by two software level passwords.
- Automatic synchronization between two or more metal detectors, at a distance of up to 5 cm, from each other, without using cables
- Professional high integration and high reliability electronics
- Electronic control unit separated from the archway
- No need for initial or periodic calibration
- Easy maintenance. The electronic control unit can be replaced in less than one minute
- Color: light gray RAL 7040

COMPARISON BETWEEN VALID ACCESSES AND FALSE ALARMS

Security level AM7
(Nielec-std-0601.00):
type "Beretta" Calibre 6,35

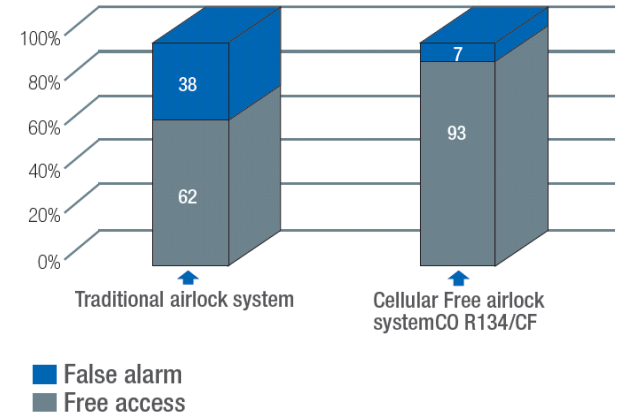



SECURITY REVOLVING DOORS

REVOLVING DOORS

Co146.180.N

Particularly suitable for stylish sites, **CoMETA Co146.NA Security Revolving Doors Series** a smart solution for entrances of: congress centers, airports, industries, companies, museums, hotels, datacenters and shopping centers. **Co146.NA Revolving Doors** are also perfect as **access control system** with the integration of badge readers and biometric devices (fingerprint acquisition).



Co146.180.N
(without doors and no base)

Co146.N: main features

- No base (directly installed on the floor)
- **Single passage checking system** on each turnstile sector: Tailgating and Piggybacking detection system
- Internal glass: BR1/S 13/14mm (optional BR3/S)
- External glass: BR2/S 20/21mm (optional BR4/S)
- Portal Console with digital display and menu-guided commands
- Intercom, voice messages and traffic-lights
- Easy-link to third party manufactured access control systems (RS232 - RS485 - IBIS interfaces)
- Proxy and swipe-card and biometric readers easily added
- Automatic unlock system in case of emergency
- Mechanical Lock for additional locking during night-times
- Armored defender for key cylinder protection, anti-drill (optional)
- Rain cover: honeycomb PVC cover cap panel, UV resistant
- Reinforced upper cover: steel panel for cap protection (optional)

Co146.NB

Model with reinforced steel structure, a special version mounted with FB4 grade bulletproof resistance steel according to UNI EN 1522.

Model	Overall Dimensions Ø x H (mm)	Passage Width L x H (mm)	Details
Co146.160.N	1600mm x 2325mm	660mm x 2090mm	3 wings turnstile (on request)
Co146.180.N	1800mm x 2325mm	750mm x 2090mm	3 or 4 wings turnstile
Co146.230.N	2300mm x 2325mm	1400mm x 2090mm	4 wings turnstile (on request)

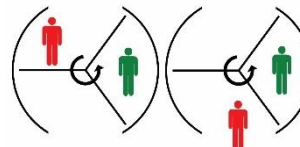

Tailgating detection system

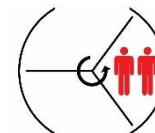

Piggybacking detection system



Co146.160.N



Co146.180.N



Co146.230.N

REVOLVING DOORS

Co147.D (with Metal Detector)

Co147.S (with Metal Detector)

CoMETA Co147.D & .S Security Revolving Doors are a multi-sectors revolving-type entrance control systems with built-in Metal Detector for patrolled areas. Additional sliding doors at the protected area dramatically improved passage flow maintaining a high security level (with 3 or 4 wings turnstiles, custom models available). **Special versions: Co147.DB and Co147.SB** with reinforced steel structure, mounted with FB4 grade bulletproof resistance steel according to UNI EN 1522.



Co147.180.D
(2-leaves door on protected side)



Co147.180.S
(1-leaf door on protected side)

Co147.D: main features

- 2-leaves door on protected side
- No base (directly installed on the floor)
- **Single person passage checking system** on each turnstile sector: Tailgating and Piggybacking detection system
- **Built-in Metal Detector** (also available without Metal Detector)
- Internal glass: BR1/S 13/14mm (optional BR3/S)
- External glass: BR2/S 20/21mm (optional BR4/S)
- Portal Console with digital display and menu-guided commands
- Intercom, voice messages and traffic-lights
- Easy-link to third party manufactured access control systems (RS232 - RS485 - IBIS interfaces)
- Proxy and swipe-card and biometric readers easily added
- Automatic unlock system in case of emergency
- Double sliding door (automatic closing system if metal detector alarmed or two persons try to get in the same sector)
- Mechanical Lock for additional locking during night-times
- Armored defender for key cylinder protection, anti-drill (optional)
- Rain cover: honeycomb PVC cover cap panel, UV resistant
- Reinforced upper cover: steel panel for cap protection (optional)

Co147.S: main features

- 1-leaf door on protected side

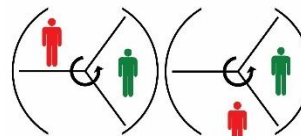

Tailgating detection system

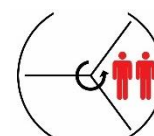

Piggybacking detection system

Model	Overall Dimensions Ø x H (mm)	Passage Width L x H (mm)	Details
Co147.180.D	1800mm x 2375mm	750mm x 2090mm	3 or 4 wings turnstile with 2 sliding doors on protected side
Co147.180.S	1800mm x 2375mm	750mm x 2090mm	3 or 4 wings turnstile with 1 sliding door on highside



REAL APPLICATIONS

REAL APPLICATIONS: ITALY

INTERLOCKING SECURITY PORTALS



REAL APPLICATIONS: ITALY

INTERLOCKING SECURITY PORTALS



REAL APPLICATIONS: ITALY

INTERLOCKING SECURITY PORTALS



REAL APPLICATIONS: OVERSEAS

INTERLOCKING SECURITY PORTALS



OUR PRODUCTS



SECURITY
LOCKS



SECURITY PORTALS
with interlocking doors



EMERGENCY EXITS
& ARMORED DOORS

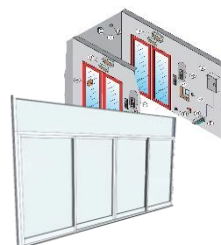

INTERLOCKING
SYSTEMS

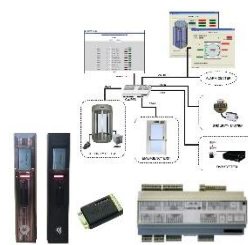

SECURITY
SYSTEMS



BIOMETRIC SYSTEMS
(Fingerprint & Face Detection)



SECURITY
REVOLVING DOORS



SPECIAL
SECURITY PORTALS



SWINGING-SLIDING
SECURITY PORTALS



TRANSPARENT
SECURITY SHUTTERS



SECURITY DRAWERS
& STORAGE CABINETS



ELECTROMAGNETS
& ACCESSORIES



CoMETA SpA

www.cometaspa.com | info@cometaspa.com

HEADQUARTERS & PRODUCTION

Florence , Italy
50028 Tavarnelle Val di Pesa
Via Leonardo Da Vinci, 116 | Tel. +39 055 8070303

Cometa France

Headquarters

Paris, France
33 Rue des Chardonnerets
ZAC de Paris Nord II
93290 Tremblay en France
+33 (0)148630204
info@cometafrance.com

CoMETA Milano

Branch

Milan, Italy
+39 3315270237
infomi@cometaspa.com

CoMETA Padova

Branch

Padua, Italy
Viale del Lavoro, 70
Z.I. Roncajette 35020
Ponte S. Niccolò
+39 0498966592
infopd@cometaspa.com